

RFID BASED SHOPPING TROLLEY

Vishakh Thrivikraman¹,

Jayadeep S², Josh Mammen C³, Sachin Vishnu⁴, Renjith S.R⁵

^{1, 2, 3, 4} Dept. of Computer Science and Engineering, College of Engineering Adoor (India)

⁵Asst. Professor, Dept. of Computer Science and Engineering, College of Engineering Adoor, (India)

ABSTRACT

Everyone loves shopping at supermarket, but equally hates the queue at the billing counter. In this paper, we explore an innovative idea of a smart shopping trolley. The central idea behind this concept is to aid the customer by reducing the time taken to bill the products bought. At present each product bought by customer has to be scanned using barcode reader to calculate the bill. This paper proposes an automated billing system using RFID and ZigBee communication. This system includes a smart shopping trolley and effective billing software. The main goal is to create a technically oriented, easily mobile and rugged system to helping shopping in person.

Keywords: RFID Reader, RFID Tag, Smart Shopping Trolley; Supermarket, Zigbee

I INTRODUCTION

Shopping has become an essential part of living, almost everything that mankind needs has to be bought. In metro cities these shopping are mostly done in supermarkets. Shopping at supermarket is mostly enjoyed by people, so anything that improves their experience will be heartily accepted. The two major problems faced by people at supermarket are the long queue at the billing counter to scan their purchase to bill them and no live tracking of the amount they have spent at purchasing at present. The enhanced smart shopping trolley intends to assist shopping in person which minimizes considerable amount of time in shopping. The trolley also displays a live feedback of the shopping. This proposed system is basically based on three technologies (1) RFID detection (2) ZigBee for wireless communication (3) Integrated system for billing.

Radio Frequency Identification (RFID) is a rapidly growing technology that has the potential to make great economic impacts on many industries. Due to latest advancements in chip manufacturing technologies, RFID has become practical for consumer level item tagging. ^[1]

ZigBee over IEEE 802.15.4 defines specifications for low data rate WPAN to support low power monitoring and controlling devices. ^[2]

Integrated system for billing is software for the billing purpose at the billing counter. It displays the information from trolley in a bill form.

Each product in the supermarket will have RFID tags to identify them. The shopping trolley for the customer consists of a microcontroller, an RFID reader, a ZigBee module and an LCD display. The RFID reader will

identify the products which will be displayed in the LCD display. The ZigBee module will send the information to integrated system for billing.

Using these RFID based shopping trolleys we can create a centralized billing system for the supermarket. All the trolleys will be connected to the central billing section of the market. Fig. 1 shows a centralized billing system for the supermarket.



Fig. 1 Centralized Billing System Using Rfid Based Shopping Trolleys

The shopping cart has the ability to calculate automatically and display the total prices of all the products inside it. This makes it easy for the customer to know how much he or she has to pay while shopping and not at the checkout counter. This way the customer can receive faster service at the checkout. The advantage for the shop owners is that they would need fewer cashiers, which would result in a large cut in their costs.

In this paper, we discuss about creating a commercially viable enhanced trolley which aid customers reduce the time spent in shopping by displaying the products, their cost and then automatically billing it. The trolley has the potential to make the shopping experience more comfortable, pleasurable and efficient for the customer.

II HARDWARE IMPLEMENTATION

Fig. 2 shows the hardware modules for the system which are attached to the trolley at supermarket. It depicts a block diagram of the shopping trolley.

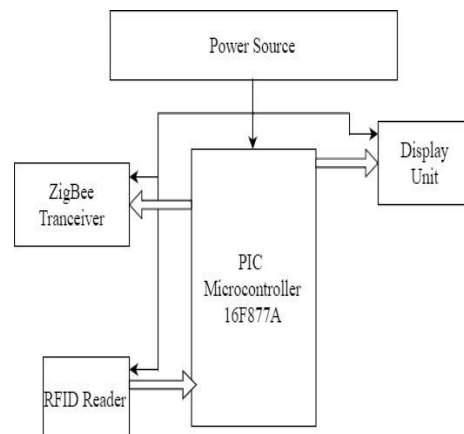

Fig. 2 Hardware Implementation Of The Shopping Trolley

A small description of each hardware module used in this shopping trolley is given:

2.1 Microcontroller

The PIC16F887A is a microcontroller usually used for small scale projects but they can be used for large scale purposes as well. It has 8KB internal flash program memory which is reprogrammable and suitable for prototyping. It also has an internal 10 bit analog-to-digital converter that allows the converting an analog data from sensors into digital signal and stores that data in EEPROM before the data extract to the computer for further analysis.^[3]



Fig. 3 Pic16f877a

In this paper, we have designed the system using PIC microcontrollers as these systems are less bulky and can be mobile. Here PIC16F877A is used to interface with RFID reader, ZigBee module and to display on LCD screen.

2.2 ZIGBEE

ZigBee is defined over IEEE 802.15.4 and used for wireless communication across 10-75 meters. It is usually used for systems that need to have long battery life. It provides low cost and low power connectivity for equipments but does not provide data transfer rates as high as those enabled by Bluetooth.^[2]

The data rate is 250kbps at 2.4 GHz, 40kbps at 915MHz and 20kbps at 868 MHz. Security, data integrity, and reliability is key features of the technology. ZigBee achieves its attractive low power consumption because of the low duty cycle expected for battery powered nodes within a ZigBee network.



Fig. 4 Zigbee Transceiver

In this paper, the proposed system uses ZigBee to communicate between the shopping trolley and the billing section of the shopping trolley. ZigBee transceiver sends the bill information to the centralized billing system.

RFID Reader

RFID is a technology to electronically record the presence of an object using radio signals. RFID complements bar-coding for distant reading of codes. The technology is used for automatically identifying a person, a package or an item.^[1]



Fig. 5 Em-18 RFID Module

EM18 RFID Reader is one of the commonly used RFID readers to read 125 kHz tags. It features low cost, low power consumption, small form factor and easy to use. It can directly interface with microcontrollers using UART and with PC using an RS232 convertor. ^[1]

In this paper, RFID reader identifies the products put into the shopping trolley. The identification of item is done by reading the 125 kHz RFID tags embedded in each item.

2.3 LCD Display

A liquid-crystal display (LCD) display uses light-modulating properties of liquid crystals. Liquid crystal uses a backlight or reflector to produce images in color or monochrome. ^[4]

Each pixel of an LCD typically consist of a layer of molecules aligned between two transparent electrodes and two polarizing filters i.e. parallel and perpendicular, the axes of transmission of which are in most of the cases perpendicular to each other. Without the liquid crystal between the polarizing filters, light passing through the first filter would be blocked by the second polarizer.

In this paper, the proposed system uses 16x2 LCD display to show the details of items put in the shopping trolley. It displays each item's information and the total amount all the items purchased.



Fig. 6 16x2 LCD Displaying RFID Based Trolley

III DESIGN

This proposed system requires both hardware and software sides to be complete. The hardware side is the smart shopping trolley while the software side includes billing software to display the bill.

The smart shopping trolley is its hardware side which consists of microcontroller, ZigBee transceiver, RFID reader and LCD display. The microcontroller is to interface with the RFID reader, ZigBee module and LCD display. The microcontroller used in this system is PIC16F877A. The PORT B of the PIC microcontroller is used to connect to LCD display. The PORT C is to interface with the RFID reader and the PORT D is for connection with the ZigBee transceiver. Power supply for the components to operate is connected to them. Various resistors and capacitors are also used to stabilize the system. ^[5]

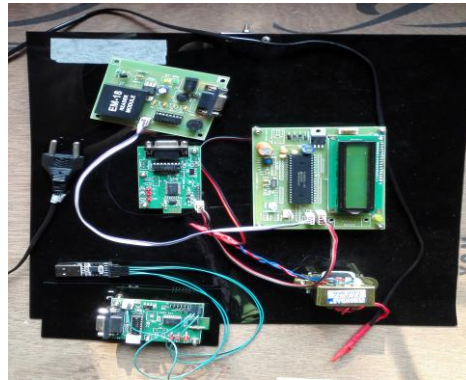

Fig. 7 Hardware Connections of Shopping Trolley

The RFID reads the item and stores it in flash memory. The PIC sends this to LCD display to show the details to the customer. The ZigBee on control of PIC send this information to the billing section.

On the billing side we would be making software for getting the itemized bill, print the bill and empty the trolley. The front end of the billing section is made using JAVA. The software receives the information serially and displays it in an animated window. It shows the name, price, quantity and amount of each item purchased. It also displays the total sum of the shopping

SUPERMARKET

Item Name	Price	Quantity	Amount

TOTAL :

Fig. 7 Screenshot of Software at Billing Section

After the customer has paid the bill the trolley is reset using a button on the trolley.

IV DEVELOPED MODEL

In this paper, we discuss the idea of creating an automated shopping system. Each trolley is connected to an RFID reader, an LCD screen, a PIC microcontroller and a ZigBee transceiver. The trolley also has a reset button to reset the trolley. The communication between the trolley and the system at the billing section is done using ZigBee. The product in the trolley is identified using the RFID reader and its information is shown in the LCD screen. This information is transmitted using ZigBee communication to the billing section.

Each product has a unique RFID tag associated to it. When an item is put in the trolley the RFID reader reads the 12 digit hexadecimal value from the RFID tag of the product. The item name and its price are then displayed in the connected LCD screen. The total amount is also displayed in the screen.

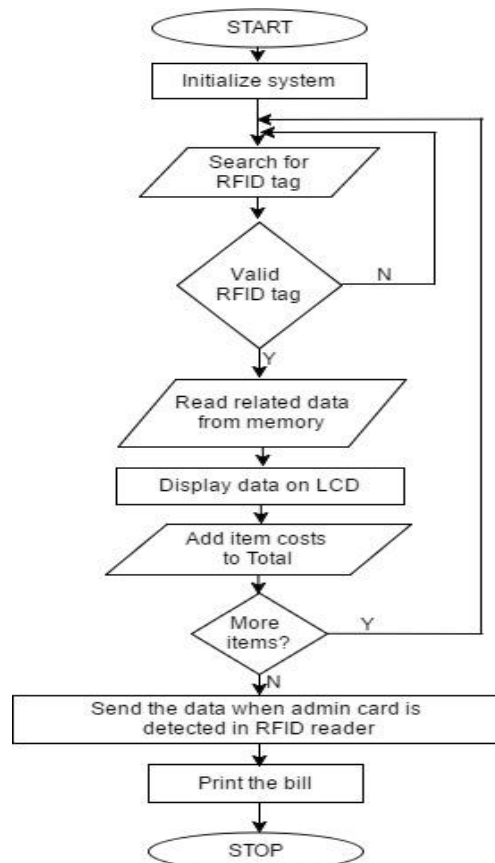

Fig. 9 Flow of Control Of The System

Finally, at the billing section when the cashier shows a admin card having a unique RFID to the trolley and it receives the billing information from the trolley. JAVA is used to create the software for displaying the bill and confirmation to print the bill. After the purchase is over the reset button in the trolley can be pressed to reset the trolley for next customers.

V CONCLUSION

The smart shopping trolley creates a centralized automated billing system for supermarkets. The system proposed is highly dependable, authentic and time-effective. The main advantage of the system is that it is time efficient as it reduces the time spent at billing section. There will also be reduction in salary amount given to employees.

Even though smart shopping carts are gaining more and more interest but there are concerns about how this will influence shopping behaviour. A considerable enhancement on the proposed system can be adding an android system to the trolley. Thereby the customer just needs to type the name of the product he wants, and the cart will show the location of the product.

REFERENCES

- [1] G. Roussos and B. College, "Enabling RFID in Retail", Computer, IEEE, vol. 39, no. 3, 2006, pp. 25-30.
- [2] Mr. P. Chandrasekar, Ms. T. Sangeetha, Smart Shopping Cart with Automatic Central Billing System through RFID and ZigBee, Proc of International Conference on Information Communication and Embedded Systems (ICICES), 2014.

4th International Conference on Recent Development in Engineering Science, Humanities and Management

National Institute of Technical Teachers Training & Research, Chandigarh, India

(ESHM-17)

2nd April 2017, www.conferenceworld.in

ISBN: 978-93-86171-19-1

- [3] N. M. Khairi, M. S. B. Shah Rizam, Md Tahir Nooritawati, M.I. Naimah, H. Zainol Abidin, System Engineering and Technology, Proc of IEEE 3rd International Conference on System Engineering and Technology, 2013.
- [4] Robert H. Chen, Liquid Crystal Displays: Fundamental Physics and Technology(Wiley, July 2011).
S.Sai Ganesh, B.Sahithi, S.Akhila, T.Venumadhav, “*RFID Based Shopping Cart*”, published in International Journal of Innovative Research in Engineering & Management (IJIREM) ISSN: 2350-0557, Volume-2, Issue-3, May-2015.