

BATTERY MANAGEMENT SYSTEM AND ITS APPLICATION IN SMART GRID AND ELECTRIC VEHICLE—A REVIEW

Jaimala Gambhir¹, Anurag Bhatia², Dr. Tilak Thakur³

^{1,2,3}Assistant Professor, Department of Electrical Engineering , PEC University of Technology, Chandigarh

ABSTRACT

In today's world rate of consumption of consuming electric energy is increasing. With increasing amount of consumption more generation sources are required which are not economically possible so we need BESS (battery energy storage system) and proper battery management system. The safety, operation, and the life of the passenger depend on the battery system and hence battery monitoring is vital for most electric vehicles (EVs). The battery management system (BMS) is an important component of electric and hybrid-electric vehicles. The purpose of the BMS is to keep the battery operation safe and reliable. The design of the battery management system plays an important role on battery life preservation, performance and improvement of electric vehicles. The purpose of this paper is to analyze the future of batteries, the Lithium-Ion cell, and to study a BMS to better understand its capabilities and possible cases for errors. Also various new techniques have been reviewed for implementing BMS as well estimation of various battery parameters lithium ion batteries are intolerant of overcharge and over-discharge. Through reviewing the latest methodologies for the state evaluation of batteries, the future challenges for battery management systems are presented.

Key words: BMS, Electric Vehicle, SOC, SOH, Li-ion.

I. INTRODUCTION

Driving range of EVs are determined by battery performance with Li-Ion battery as its preferred battery option due to its good power ratings, energy densities, high charge /discharge efficiency Series connected Li-Ion cells are generally used whose chemistry is sensitive to overcharge and deep discharge that causes damage, lifetime shortening and explosions that are dangerous for the users thus a proper battery management system(BMS) should be employed to estimate status in order to predict actual amount of charge stored and remaining useful life. The smart grid and EVs are two examples of growing technologies that would greatly benefit from the development of advanced infrastructure and components.

In [1] the analysis and simulation of Li-ion battery charging process for a solar power battery management system is done by using non inverting Buck-Boost DC/DC power converter. Rapid changes in atmospheric conditions causes fluctuations in voltage and these sudden changes will make the system to switch between buck, boost and buck-boost modes. The terminal voltage of solar cell panel is kept higher than required load voltage. Controlling and monitoring of stored solar power drawn from solar cell is done using MATLAB based Simulink piecewise linear electric simulation tool. One of the most important functions of BMS is to balance the unbalanced cells which decrease the battery life. Various cell balancing topologies have been developed and

reviewed. In [2] a strategy to improve system performance using single switched capacitor (SSC) cell balancing technique is proposed. The fundamental function of BMS usually is to monitor the battery status, to protect the battery from over-current, to determine state of charge (SOC), to balance unbalanced battery cells and it should be able to protect battery over-charge/over-discharge.

II. LITHIUM-ION BATTERY

The energy density per unit weight of Lithium metal is very high. Using lithium as the anode, high voltage is obtained, excellent capacity and a high-energy density. The lithium-ion battery requires almost no maintenance during its lifecycle, which is an advantage that other batteries do not have. The disadvantages of lithium-ion batteries are that lithium ions are brittle. For safe area of operation of these batteries a proper BMS will be implemented to limit the peak voltage of each cell during charging and to prevent the cell voltage from dropping below a threshold during discharging. The self-discharge rate of lithium-ion battery is half of lead-acid and Ni-MH batteries.

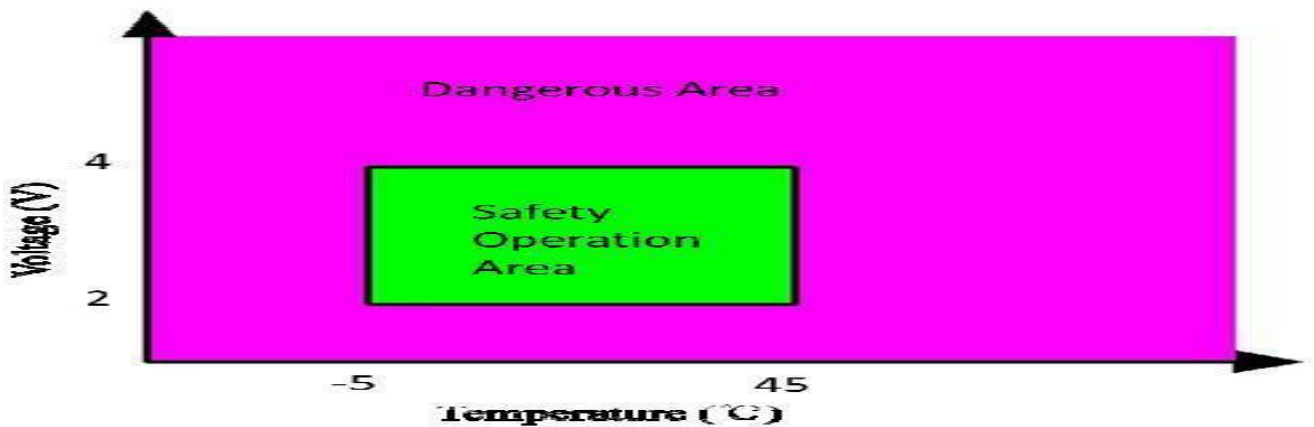

Figure 1: Lithium-ion cell operation window (Voltage)

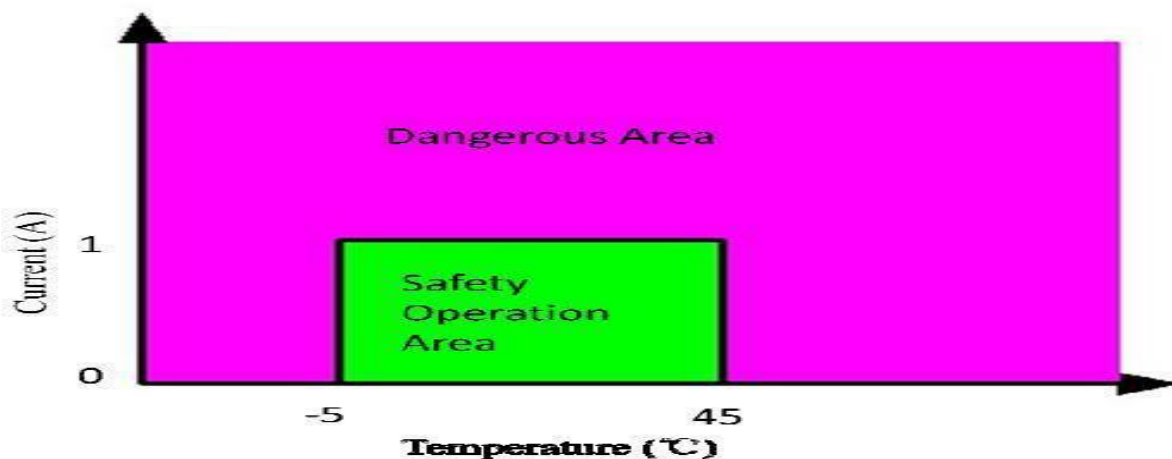

Figure 2: Lithium-ion cell operation window (Current)

III. LITHIUM BATTERY CHALLENGES:

The operating temperature and voltage are the most important parameters that determine the performance of lithium-ion cells. Figure 1 and 2 shows that the cell operating voltage, current and temperature must be maintained within the area indicated by the green box labeled "Safety Operation Area" (SOA) at all times.

The cell could be permanently damaged if it is operated outside the safety zone. The batteries could be charged above its rated voltage or be discharged under the recommended voltage. If the recommended upper limit of 4.2 V was exceeded during charging, excessive current would flow and result in lithium plating and overheating. On the other hand, overly discharging the cells or storing the cells for extended periods of time would cause the cell voltage to fall below its lower limit, typically 2.5 V. This could progressively break down the electrode. The operating temperature of lithium-ion cells should be carefully controlled because excessively high or low temperatures could damage the cell. Temperature-related damages could be grouped into three types: low-temperature operational impact, high temperature operational impact and thermal runaway. While the effects of voltage and temperature on cell failures are immediately apparent, their effects on the lifecycle of the cells are not as obvious. However, the cumulative effects of these degradation may affect the lifetime of the cells. It is clear from the discussion above that the goal of the BMS is to keep the cells operating within their safety zone; this could be achieved using safety devices such as protection circuits and thermal management systems.

IV. LITERATURE REVIEW

The main task of BMS is to balance each cell unit as cell unbalancing degrades electric vehicles performance. The BMS perform several tasks such as measuring the system voltage, current, temperature, SOC, state of health(SOH), Remaining Useful Life(RUL), thermal management, controlling the charge/discharge operation, data acquisition, communication with ON/OFF module, storing, monitoring and analyzing historical data and most important function of BMS is cell balancing [5]. To meet the requirements of traction converter, series connected battery packs are used in BEVs. But the unbalanced cells connected in series causes damage in service lifetime. In order to minimize these effect caused by cell unbalancing a second DC-DC converter is used and is controlled by BMS. A third converter also employed to recharge cell from a.c. utility grid. The entire three converters can be replaced by using Modular multilevel converters (MMC) without supplying voltage on DC bus-bar [3]. In [6] a model of energy regenerative braking control of electric vehicles using sliding mode robust controller is designed. The unbalance between energy required and energy produced from generation sources causes wastage of power. In today's world rate of consumption of consuming electric energy is increasing. With increasing amount of generation sources are required which are not economically possible so we require BESS (battery energy storage system) and proper battery management system. Detailed modeling is extremely useful for predicting accurate SOC and SOH. Unfortunately state of charge can't be accurately estimated by tracking the flow of charge (coulomb counting) because of inaccuracies of current meter: slow, variable losses inside the battery and side reactions occurring in the system. Estimations of SOC based on the current must account for all the physical realities of the battery and its measurement system like cell self-discharge and series string charge among others. Most commonly open circuit terminal voltage is used as an indicator of SOC [7]. In [8] a voltage recovery method is used in which a load is applied to the battery and

Voltage depression under load and temporal recovery of the battery voltage after removal of the load are monitored and used to estimate State of Health (SOH). The authors in [9] have researched and eliminated limitation of stand-alone coulomb counting by using it with open circuit voltage method which is further corrected by kalman filter. The battery depreciation process needs to be reduced by conditioning the battery in a suitable manner by controlling its charge/discharge profile, even under various load conditions. Due to adverse thermal conditions, frequent charging cycle and deep discharging causes battery life shortening. An assessment of partitioning schemes for real time execution on multicore targets to ensure efficient use of hardware resources had been done. As the battery pack size increases, the computational demand of the solver for the simulation of system increases. Real time execution on multicore targets appears to be suitable for battery pack simulation because of repetitive nature of battery pack suggest a relatively straightforward way to even partition the system. In Simulink, the user configures a model for on-target concurrent by assigning separate tasks to different parts of the model at the top level. An integral multiple of top level model step size has been assigned as sampling time for each task. The author discussed about the BMS and modeled it for smart-grid application [10]. In [11] the authors designed an EV model to generate current profile from the velocity profile of various driving cycles. An automated multistage parameter identification technique applied at different aging states of Li-ion battery enabling the determination of changes in cell parameters. In [12] a new BMS is proposed which provides a fault tolerant capability and battery protection. In figure 3 an overview of BMS is shown.

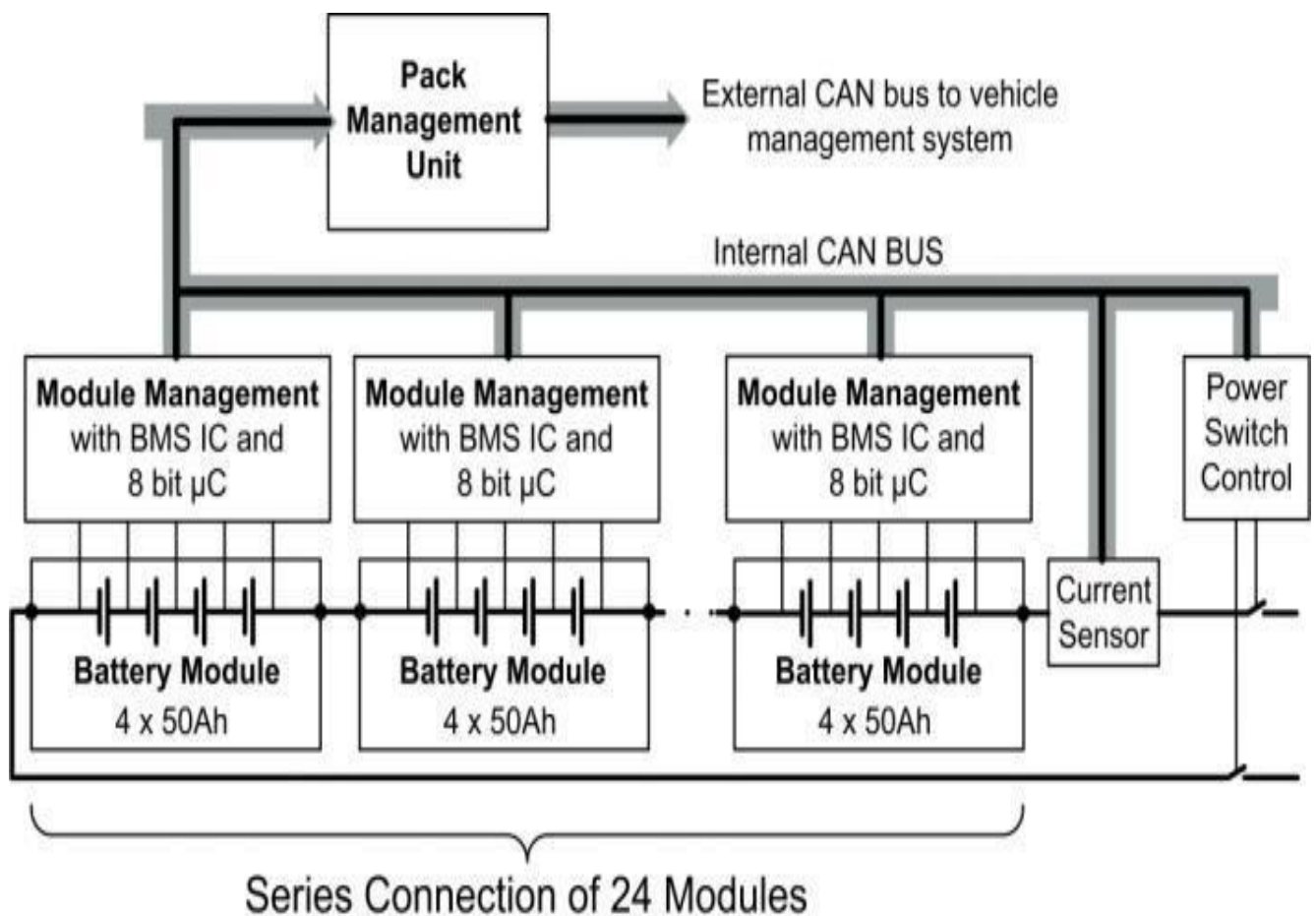

Figure 3: Battery system overview

Battery Management System for Smart Grid is in high demand as consumption of energy is increasing exponentially while non-conventional sources are not good option due to carbon emissions. While renewable sources like sun energy and wind energy are abundant but lacks a proper storage system. For stable transfer of energy from grid to battery or vice versa a proper BMS enabled monitoring is required. Data from individually monitored battery cell unit is analyzed and various parameters like SOC, SOH, and V are measured. The isolated battery is bypassed to maintained uninterrupted supply [43]. Pareto optimal curve for various cases have been simulated and analyzed to get an optimal solution for cost minimization [44].

Battery model should account for thermal effects because of paramount importance of temperature in kinetic and transport phenomenon of electrochemical systems. A multi-temp Li-ion cell simulation with thermal dependence is developed. A parameter estimation numerical scheme using pulse current discharge test on high power lithium cell under different operation reveals relation between equivalent circuit elements and SOC, current, temperature [46].

A simulation error minimization method is used in model whose parameter is optimized by hybrid optimization method combining with least square approach. A joint Extended Kalman Filter (EKF) [28] is applied on thermoelectric model to estimates model parameters and model states simultaneously [47]. Cell inconsistency problem arises in parallel connection of Li-ion cell is investigated and physical model is developed [47]. In [48] various mathematical techniques that are generally used in modeling of BMS have been studied. A monitoring system for battery power electric vehicle was implemented and tested. The system allows temperature and voltage monitoring of each of 24 batteries which allows detecting early problems or failures in individual batteries using ‘one wire’ which allows transmitting data from all batteries through serial bus [49]. A flexible method is introduced for constructing battery pack model suitable for partitioning and multicore execution on real time targets. The eight cell model ran in real time vs. with a performance that qualitatively agreed with the desktop profiling prediction when tested under different portioning conditions [50].

IV. CONCLUSION

It has been concluded that various new methods for evaluating battery parameters has been developing by researchers and new technologies like BMS for safe operation of batteries are very essential for a clean transportation and stable grid operation as well as safety of passenger’s life. A smart BMS is important for the smart grid and for the growth of the EVs industry. The development of new battery technology that provides higher energy and power density and reduces cost cannot be fully obtained without proper BMS circuits and algorithms to control and monitor the real time data of battery for the safety and reliability of the energy storage devices.

REFERENCES

- [1] F. Baronti et al., "Design and Verification of Hardware Building Blocks for High-Speed and Fault-Tolerant In-Vehicle Networks," *IEEE Trans. Ind. Electr.*, vol. 58, no. 3, pp. 792–801, Mar. 2011.
- [2] P. Wolfs, "An economic assessment of “second use” lithium-ion batteries for grid support," in *Proc. 20th Australasian Universities Power Engineering Conference (AUPEC)*, Dec. 2010, pp. 1–6.

- [3] A. Manenti, et al., "A new BMS architecture based on cell redundancy," *IEEE Trans. Ind. Electron.*, vol. 58, no. 9, pp. 4314–4322, 2011.
- [4] J. Cao, N. Schofield, and A. Emadi, "Battery balancing methods: A comprehensive review," in *Proc. IEEE Conf. Vehicle Power and Propulsion*, 2008, pp. 1–6.
- [5] F. Baronti, et al., "Hierarchical platform for monitoring, managing and charge balancing of LiPo batteries," in *Proc. Vehicle Power and Propulsion Conf.*, Sep. 2011, pp. 1–6.
- [6] S. Piller, M. Perrin, and A. Jossen, "Methods for state-of-charge determination and their applications," *Journal of Power Sources*, vol. 96, no. 1, pp. 113–120, 2001.
- [7] H. He, et al., "State-of-charge estimation of lithium-ion battery using an adaptive extended kalman filter based on an improved thevenin model," *IEEE Trans. Veh. Technol.*, vol. 60, no. 4, pp. 1461–1469, May 2011.
- [8] F. Codeca, S. Savaresi, and G. Rizzoni, "On battery state of charge estimation: A new mixed algorithm," in *Proc. IEEE Int'l Conf. on Control Applications*, Sep. 2008, pp. 102–107.
- [9] F. Baronti, et al., "State-of-Charge Estimation Enhancing of Lithium batteries through a Temperature-Dependent Cell Model," in *Proc. IEEE Applied Electronics*, Sep. 2011, pp. 1–5. N. Naik-Dhungel, "Portfolio standards and the promotion of combined heat and power," *Com-bined Heat and Power (CHP) Partnership Port-folio*, U.S. Environmental Protection Agency (EPA), Washington, DC, 2013.
- [10] T. Appenzeller. (2004, June). End of cheap oil. *National Geographic Magazine*. [Online]. Available: <http://ngm.nationalgeographic.com/ngm/0406/feature5/>
- [11] J. Eyer and G. Corey, "Energy storage for the electricity grid: Benefits and market potential assessment guide. A study for the DOE energy storage systems program," Sandia National Laboratories, Albuquerque, NM and Liver-more, CA, Rep. SAND2010-0815, Feb. 2010.
- [12] A. Khaligh and Z. Li, "Battery, ultra-capacitor, fuel cell, and hybrid energy storage systems for electric, hybrid electric, fuel cell, and plug-in hybrid electric vehicles: State of the art," *IEEE Trans. Veh. Technol.*, vol. 59, no. 6, pp. 2806–2814, July 2010.
- [13] J. Intrator, E. Elkind, S. Weissman, and M. Sawchuk, "2020 strategic analysis of energy storage in California," California Energy Com-mission, Sacramento, CA, Rep. CEC-500-2011-047, 2011.
- [14] T. Logenthiran and D. Srinivasan, "Intelligent management of distributed storage elements in a smart grid," in *Proc. 2011 IEEE 9th Int. Conf. Power Electronics and Drive Systems (PEDS)*.
- [15] J.-Y. Kim, H.-M. Kim, S.-K. Kim, C. Cho, J.-M. Kim, J. B. Ahn, and K.-Y. Nam, "Development of hardware in-the-loop simulation system for testing operation and control functions of mi-crogrid," *IEEE Trans. Power Electron.*, vol. 25, no. 12, pp. 2919–2929, 2010.

- [16] Z. Zhang and M.-Y. Chow, "Convergence analysis of the incremental cost consensus algorithm under different communication net-work topologies in a smart grid," *IEEE Trans. Power Syst.*, vol. 27, no. 4, pp. 1761–1768, 2012.
- [17] A. Burke, B. Jungers, C. Yang, and J. Ogden, "Bat-tery electric vehicles: An assessment of the technology and factors influencing market read-iness," Public Interest Energy Research (PIER) Program, California Energy Commission, Ad-vanced Energy Pathways (AEP) Project, Sacra-mento, CA, July 2007.
- [18] D. A. Corrigan and A. Masias, "Batteries for electric and hybrid vehicles," in *Linden's Hand-book of Batteries*, T. B. Reddy, Ed., 4th Ed. New York: McGraw-Hill, 2011
- [19] W. Haiying, W. Feng, F. Ying, L.i Ran, and Z. Qian, "Study on key technologies of lithium battery for electric vehicle," in *Proc. 2011, 6th Int. Forum Strategic Technology (IFOST)*, vol. 1, pp. 291–294.
- [20] H. R. Eichi and M.Y. Chow, "Modeling and analysis of battery hysteresis effects," in *Proc. 2012 IEEE Energy Conversion Congr. Expo. (ECCE)*..
- [21] F. Baronti, G. Fantechi, R. Roncella, and R. Saletti, "Intelligent cell gauge for a hierarchical battery management system," in *Proc. 2012 IEEE Transportation Electrification Conf. Expo. (ITEC)*, pp. 1–5.
- [22] M. M. Wenger, J. L. Grosch, M. Giegerich, M. P. M. Jank, M. Marz, and L. Frey, "Novel cost-efficient contactless distributed monitoring concept for smart battery cells," in *Proc. 2012 IEEE Int. Symp. Industrial Electronics (ISIE)*, pp. 1342–1347.
- [23] K. S. Ng, C.-S. Moo, Y.-P. Chen, and Y.-C. Hsieh, "Enhanced coulomb counting method for estimating state-of-charge and state-of-health of lithium-ion batteries," *Appl. Energy*, vol. 86, no. 9, pp. 1506– 1511, Sept. 2009.
- [24] N. A. Windarko, C. Jaeho, and C. Gyo Bum, "Improvement of electrical modeling of NiMH battery for application of Microgrid System," in *Proc. 2010 IEEE Energy Conversion Congr. Expo. (ECCE)*, pp. 4243–4248.
- [25] F. Codeca, S. M. Savaresi, and V. Manzoni, "The mix estimation algorithm for battery state-of-charge estimator: Analysis of the sensitivity to measurement errors," in *Proc. Joint 48th IEEE Conf. Decision and Control and 2009 28th Chinese Control Conf., CDC/CCC 2009*, Shanghai, China, pp. 8083–8088
- [26] R. Li, J. Wu, H. Wang, and G. Li, "Prediction of state of charge of lithium-ion rechargeable battery with electrochemical impedance spec-troscopy theory," in *Proc. 5th IEEE Conf. Indus-trial Electronics and Applications, ICIEA 2010*, Taichung, Taiwan, pp. 684–688.
- [27] T. Huria, M. Ceraolo, J. Gazzarri, and R. Jackey, "High fidelity electrical model with thermal dependence for characterization and simula-tion of high power lithium battery cells," in *Proc. 2012 IEEE Int. Electric Vehicle Conference (IEVC)*, pp. 1–8.
- [28] G. L. Plett, "Extended Kalman filtering for battery management systems of LiPB based HEV battery packs—Part 2: Modeling and identification," *J. Power Sources*, vol. 132 ,Aug. 2004.
- [29] I.-S. Kim, "Nonlinear state of charge estimator for hybrid electric vehicle battery," *IEEE Trans. Power Electron.*, vol. 23, no. 4, pp. 2027–2034, July 2008.

- [30] H. Rahimi-Eichi, F. Baronti, and M. Y. Chow, "Modeling and online parameter identification of Li-polymer battery cells for SOC estimation," in Proc. 2012 IEEE Int. Symp. Industrial Electronics (ISIE), pp. 1336–1341.
- [31] H. Rahimi Eichi and M. Y. Chow, "Adaptive parameter identification and state-of-charge estimation of lithium-ion batteries," presented at the 38th Annual Conf. IEEE Industrial Electronics Society (IECON 2012), Montreal, QC, Canada.
- [32] H. Rahimi Eichi, F. Baronti, and M.-Y. Chow, "On-line adaptive parameters identification and SOC co-estimation for Li-polymer battery cells," IEEE Trans. Ind. Electron., to be published.
- [33] J. Vetter, P. Novák, M. R. Wagner, C. Veit, K. C. Möller, J. O. Besenhard, M. Winter, M. Wohl fahrt Mehrens, C. Vogler, and A. Hammouche "Ageing mechanisms in lithium-ion batteries," J. Power Sources, vol. 147, nos. 1–2, pp. 269– 281, Sept. 2005.
- [34] M. Ecker, J. B. Gerschler, J. Vogel, S. Käbitz, F. Hust, P. Dechent, et al., "Development of a life-time prediction model for lithium-ion batteries based on extended accelerated aging test data," J. Power Sources, vol. 215, pp. 248–257, Oct. 2012..
- [35] M. Uno and K. Tanaka, "Accelerated ageing testing and cycle life prediction of super-capacitors for alternative battery applications," in Proc. 2011, 33rd Int. Telecommunications Energy Conf. (INTELEC 2011), Piscataway, NJ, p. 6.
- [36] I.-S. Kim, "A technique for estimating the state of health of lithium batteries through dual sliding mode observer," IEEE Trans. Power Electron., vol. 25, no. 4, pp. 1013–1022, Apr. 2010.
- [37] A. Eddahech, O. Briat, N. Bertrand, J. Y. Delétage, and J. M. Vinassa, "Behavior and state of health monitoring of Li-ion batteries using impedance spectroscopy and recurrent neu-ral networks," Int. J. Electr. Power Energy Syst., vol. 42, pp. 487–494, 2012.
- [38] E. Koshimoto, C. C. Quach, E. F. Hogge, T. H. Strom, B. L. Hill, S. L. Vazquez, and K. Goebel, "Battery health management system for electric UAVs," in Proc. 2011 IEEE Aerospace Conf, pp. 1–9.
- [39] B. Sana, K. Goebel, and J. Christophersen, "Comparison of prognostic algorithms for estimating remaining useful life of batteries," Trans. Inst. Meas. Contr., vol. 31, pp. 293–308, June–Aug. 2009.
- [40] V. Ramadesigan, P. W. C. Northrop, S. Santhanagopalan, R. D. Braatz, and V. R. Subramanian, "Modeling and simulation of Lithium-ion batteries from a systems engineering perspective," J. Electrochem. Soc., vol. 159, no. 3, pp. R31–R45, 2012.
- [41] R. Klein, N. A. Chaturvedi, J. Christensen, Ahmed, R. Findeisen, and A. Kojic, "Electro-chemical model based observer design for a Lithium-ion battery," IEEE Trans. Control Syst. Technol., vol. 21, no. 2, pp. 1–13, Mar. 2012.
- [42] P. E. Pascoe and A. H. Anbuky, "VRLA battery discharge reserve time estimation," IEEE Trans. Power Electron., vol. 19, no. 6, pp. 1515– 1522, Nov. 2004.
- [43] M. Chen and G. A. Rincon-Mora, "Accurate electrical battery model capable of predict-ing runtime and I-V performance," IEEE Trans. Energy Convers., vol. 21, no. 2, pp. 504–511, June 2006.
- [44] M. A. Roscher and D. U. Sauer, "Dynamic electric behavior and open-circuit-voltage modeling of LiFePO4-based lithium ion secondary batteries," J. Power Sources, vol. 196, no. 1, pp. 331–336, Jan. 2011.

- [45] J. Cao, N. Schofield, and A. Emadi, "Battery balancing methods: A comprehensive review," in Proc. 2008 IEEE Vehicle Power and Propulsion Conf. VPPC '08, pp. 1–6.
- [46] B. Lindemark, "Individual cell voltage equalizers (ICE) for reliable battery," in Proc. 1991, 13th Int. Telecommunications Energy Conf. INTELEC '91, pp. 196–201.
- [47] H.J. Bergveld, Battery Management Systems Design by Modeling, 2001, ISBN 90-74445-51-9.
- [48] Shepherd, C. M., Design of Primary and Secondary Cells - Part 2. An equation describing battery discharge, Journal of Electrochemical Society, Volume 112, July 1965, pp 657-664.
- [49] Olivier Tremblay, Louis-A. Dessaint, Experimental Validation of a Battery Dynamic Model for EV Applications, World Electric Vehicle Journal Vol. 3 - ISSN 2032-6653
- [50] D. Fisher, A. Lohner, and P. Mauracher, "Battery management: Increase in the reliability of UPS," ETZ, vol. 117, pp. 18–22, 1996.