

GSM BASED GAS LEAKAGE DETECTION SYSTEM

Rahul Gupta¹ Shubham Meena² Salman Khan³ Raghunandan Garg⁴

Rahul joshi⁵

(Assistant Professor Department of Electrical Engineering GIET Kota¹) 4th Year

(GIET Kota^{2, 3, 4, 5})

ABSTRACT

Gas leakage is a major problem with industrial sector, residential premises and gas powered vehicles like CNG (compressed natural gas) buses, cars. One of the preventive methods to stop accident associated with the gas leakage is to install gas leakage detection kit at vulnerable places. The aim of this paper is to present such a design that can automatically detect and stop gas leakage in vulnerable premises. In particular gas sensor has been used which has high sensitivity for propane (C_3H_8) and butane (C_4H_{10}). Gas leakage system consists of GSM (Global System for mobile communications) module, which warns by sending SMS. However, the former gas leakage system cannot react in time. This paper provides the design approach on both software and hardware.

Keywords: Global System for mobile communications (GSM), compressed natural gas (CNG), Liquefied petroleum gas (LPG), Gas sensor MQ-6, stepper motor Driver IC (ULN2003A), Microcontroller (AT89C51), LCD (Liquid crystal display), RF (Radio Frequency) link, Decoder HT12D, Encoder HT12E

I. INTRODUCTION

LPG consists of mixture of propane and butane which is highly flammable chemical. It is odorless gas due to which Ethanethoil is added as powerful odorant, so that leakage can be easily detected. There are other international standards like EN589, amyl mercaptane and tetrahydrothiophene which are most commonly used as odorants. LPG is one of the alternate fuels used now days. Sometimes liquefied petroleum gas is also known as LPG, LP gas, Auto gas etc. This gas is commonly used for heating appliances, hot water, cooking, and various other purposes also. LPG is also used as an alternate fuel in vehicles due to soaring in the prices of petrol and diesel.

Some people have low sense of smell, may or may not respond on low concentration of gas leakage. In such a case, gas leakage security systems become an essential and help to Protect from gas leakage accidents. A number of research papers have been published on gas leakage security system [13].

Embedded system for Hazardous gas detection and Alerting has been proposed in literature [7]. Where the alarm is activate immediately, if the gas concentration exceeds normal level. I.



Bhopal gas tragedy was an example of gas leakage accident in India. This was world's worst gas leakage industrial accident gas supplies turn off. At the end, when the gas leakage is successfully stopped then with the help of reset button the whole system reached to the initial stage.

Gas leakage detection is not only important but stopping leakage is equally essential. This paper provides a cost effective and highly accurate system, which not only detect gas leakage but also alert (Beep) and turn off main power and gas supplies, and send an SMS. GSM1 module is used which alert the user by sending an SMS [2]. In order to provide high accuracy gas sensor MQ-6 has been used.

II.METHODOLOGY USED

The functionality of system is divided into three main steps. The fig. 1 shows the block diagram of gas leakage Security system.

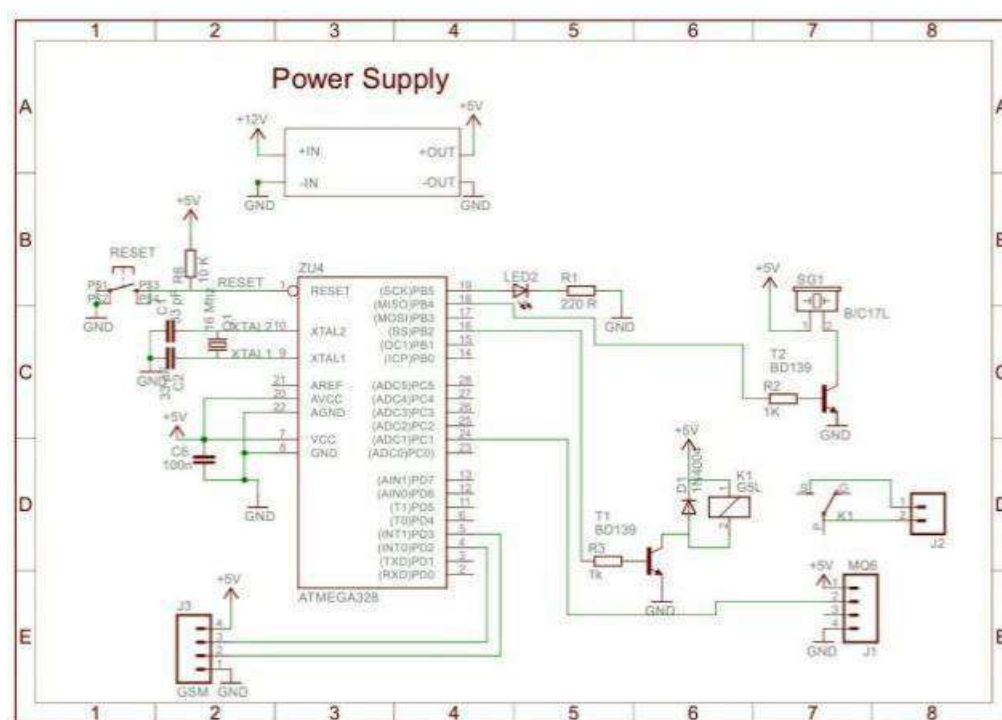

Fig. 1 Block diagram of gas leakage security system

In the initial step, the gas leakage is detected by the gas sensor MQ-6. This detects the gas leakage and gives the signal 2 pins are used for providing heating current. This sensor has fast response time.

To the microcontroller with the help of ADC after than in second step the microcontroller receive the signal, send by gas sensor. It sends activation signal to other external devices attached with it. Such as two stepper motor IC (ULN 2003A), buzzer, LCD (Liquid crystal display), GSM module



[10] And RF link. In the last step, many tasks have been performed such as buzzer activates simultaneously message display on liquid crystal display screen GSM module activated, which send warning SMS to the user. Stepper motor IC (ULN 2003A) to drives the stepper motor attached it, as a result main power.

A.MQ-6 Gas Sensors

MQ6 is a semiconductor type gas sensor which detects the gas leakage. The sensitive material of MQ-6 is tin dioxide (SnO_2). It has very low conductivity in clean air [4]. This Gas sensor not only has sensitivity to propane and butane but also to other natural gases, low sensitivity to cigarette smoke and alcohol. The MQ-6 gas sensor is shown in fig. 2. This sensor can also be used for detection of other combustible gas such as methane

B GSM Receiver



Fig. 2 MQ-6

The power need by the sensor is 5V. This sensor has different resistance value in different concentration. For an example, if we calibrate the MQ-6 gas sensor to the 1000ppm of propane

DC 5V BUTHEN & LPG GAS SENSOR [5]

The concentration range of MQ-6 gas sensor is 300-10000 ppm. This sensor is available in 6 pins package, out of which 4 pins are used for fetching the signals and other

Concentration in air, then the resistance value would be approximately 20k ohm .the change in the resistance value with respect to the concentration as discussed above is shown in fig 3

GSM module is used to send an SMS to the user cell phone [8].When the gas leakage is detected by the gas sensor, microcontroller sends a signal to GSM module [2], in which one of the tasks is to send the text SMS. GSM module requires one SIM card [17]. This module is capable to accept any network SIM card. Fig. 4 shows a GSM module IC(Integrated circuit). This module has a unique identity number like mobile phones have. These module works on 12V DC supply [18]. We can send SMS and also send a voice message. These SMS or voice messages are saved in the microcontroller memory. Multiple SMSs can also be sends to user, police and fire station etc.

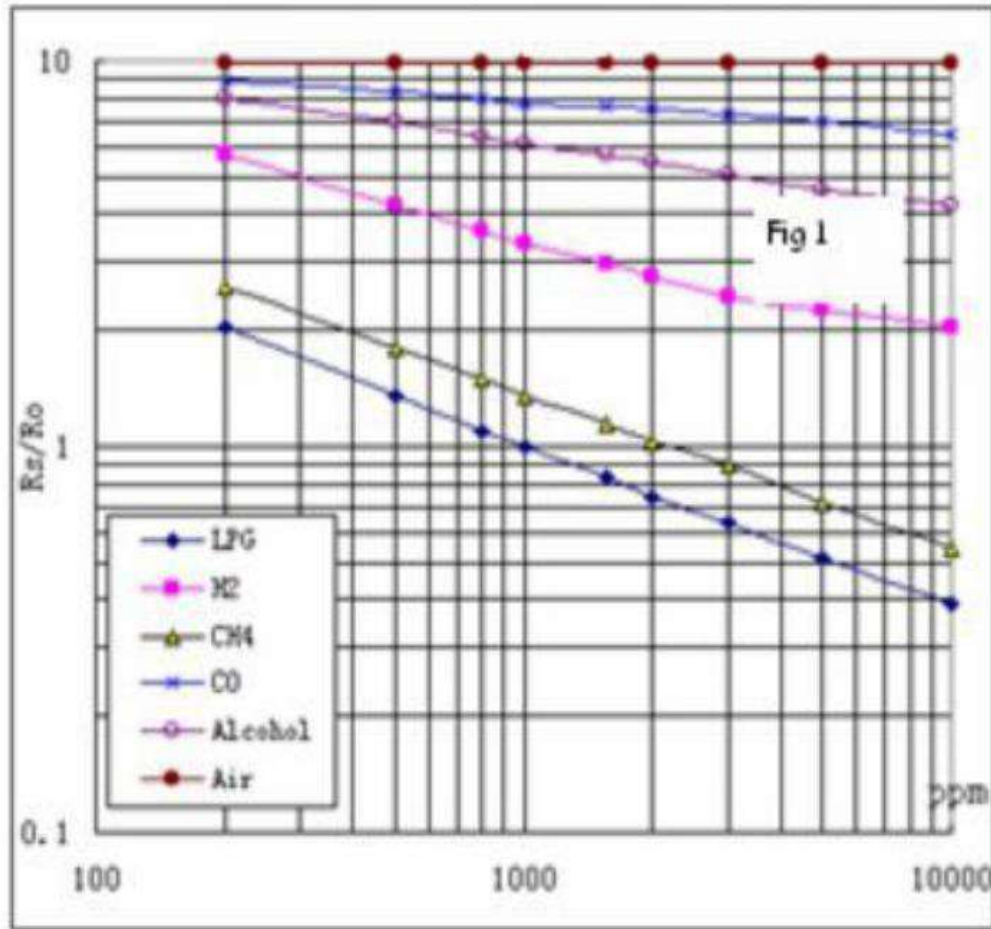

FIG: Sensitivity characteristic of the MQ-6 For several gases

Fig is shows the typically sensitivity characteristics of the MQ-6 For several gases in their

Temp: 20°C.

Humidity: 65%

O₂ concentration: 21%

R_o: sensor resistance at 1000ppm of LPG in the clean air

R_s: sensor resistance at various concentration of gases

Gas Sensor MQ6 VS MQ5

LPG Gas Sensor (MQ6) Features:



1. High Sensitivity to LPG,

Iso-butane, *propane*

2. Small sensitivity to alcohol, Smoke

3. Fast Response Time: <10s

4. Detection Range: 100 - 10,000 ppm

Iso-butane propane

5. Simple drive circuit

6. Heater Voltage: 5.0V

Dimensions:

1. 18mm Diameter

2. 17mm high excluding pins

3. Pins - 6mm High

Applications:

1. Gas leak detection system

2. Fire/Safety detection system

3. Gas leak alarm

4. Gas detector

(LPG, Iso-butane, Propane)

LPG Gas Sensor (MQ5) Features:

1. High sensitivity to LPG,

Natural gas

2. Small sensitivity to alcohol, smoke.

3. Fast response .

4. Detection Range:

200-10,000ppm.

5. Simple drive circuit
6. Heater Voltage: 5.0V

Dimensions:

1. 18mm Diameter
2. 17mm High excluding pins
3. Pins - 6mm High

Applications:

1. Gas leak detection system
2. Fire/Safety detection system
3. Gas leak alarm
4. Gas detector

(LPG, Natural gas)



FIG.4 GSM module IC

III. RESULT

The prototype of the gas leakage security system has been shown in fig. 6. This system has been tested by taking a small amount of LPG gas near to the sensor. MQ-6 gas sensor detects the LPG gas and sends a signal to the microcontroller. After that microcontroller send an active signal to other externally connected devices. As a result a buzzer rings and a message is display on LCD screen. Simultaneously main power and gas supply turns off with the help of stepper motor and GSM module send an SMS

[3]. When reset button is pressed, the system refreshes itself and whole system regains its initial position.

IV. CONCLUSION

In this system we have describe a new approach for gas leakage detection system at a low concentration. The leakage is detected with the help of MQ-6 gas sensor. Sensor sends a signal to microcontroller. In the next step microcontroller sends an active signal to other externally connected devices. The efficiency and memory of the microcontroller can be increased if Philips microcontroller is used in place of AT89C51. multiple SMS can be send by changing programming GSM module. To change the SIM card we have to make changes in program.

REFERENCES

- [1] H. Huang, H. Bainand S. Zhu, "A Greenhouse Remote Monitoring System Based on GSM," in *Proc. of IEEE International Conference on information management*, pp. 357-360, 2011
- [2] Y. Mengda and Z. Min, "A Research of a new Technique on hardware implementation of Control Algorithm of High-Subdivision for Stepper Motor," in *Proc. of 5th IEEE Conference on Industrial Electronics and Application*, pp. 115-120, 2011.
- [3] H. G. Rodney Tan, C. H. Lee and V. H. Mok, "Automatic Power Meter Reading System Using GSM Network," in *Proc. of the 8th International Conference (IPEC2007)*, pp. 465 - 469, 2007.
- [4] L. Shaw, S. Bagha, A. G. Mahapatra and N. Nayak, "Kernel Approach on Detection of Ethanol conneti using Zno Gas Sensor," *International Journal of Machine Learning and computing*, vol. 2, no. 1, Feb. 2012.
- [5] S. Shinde, S. B. Patil and A. J. Patil, "Development of movable gas tanker leakage detection using wireless sensor network based on embedded system," *International Journal of Engineering Research and Application(IJTERA)*, vol. 2, pp. 1180-1183, Nov.-Dec. 2012.
- [6] J. L. Solis, Y. Li and L. B. Kishs, "Fluctuation-Enhanced Multiple-gas sensing by Commercial Taguchi Sensor," *IEEE Sensor Journal*, vol. 5, no. 6, Dec 2005.
- [7] V. Ramya and B. Palaniappan, "Embedded system for Hazardous gas detection and Alerting," in *Proc. of International Journal of Distribted and parallel system(IJDPS)*, vol. 3, no. 3, May 2012.
- [8] T. Murugan, A. Periasamy and S. Muruganand, "Embedded Based Industrial temperature monitoring system using GSM," *International Journal of computer application*, vol. 58, no. 19, Nov. 2012. *Proc. of IEEE International Journal of advanced engineering and studies*, vol. 1, pp. 178-180, 2012.
- [9] J. G. Gajipara and prof. K. A. sanagara, "Stepper motor driver for high speed control by high voltage and constant current," in *Proc. of IEEE International Journal of advanced engineering and studies*, vol. 1, pp. 178-180, 2012.
- [10] A. Jain, D. kumar and J. Kedia, "Design and development of GSM based energy Meter," *International Journal of Computer Application*, vol. 47, no. 12, June 2012.
- [11] K. Wang-Hay tusi, C. Cheung and kadett Chi-Wah Yuen, "Novel Modeling and damping technique for Hybrid Stepper Motor," *IEEE Trans. on Ind. Electrons*, vol. 56, no. 1, Jan. 2009.



- [12]A. J. Blauch, Marc. Bodson and J. Chiasson, “ High-Speed Parameter Estimation of stepper motors,” *IEEE trans. of on control system Tech.*, vol.1, no. 4, Dec. 1993.
- [13] D. Stoianovici, A. Patriciu, D.g Petrisor, D. Mazilu and L. kavoussi, “A new type of motor: Pneumatic step Motor,” *IEEE/ASME Trans. of Mechatronic*, vol. 12, no. 1, Feb 2007.
- [14] Xiaohua Zhang and Bingji Xgu, “Research on Stepper Motor Control Based on Single Chip and Serial Communication,” in *Proc. of the 8thworld congress on Intelligent control and Automation*, July 2010, China.
- [15]M. Yuchun, H. Yinghong, Zhang Kun and Li Zhuang, “General Application Research on GSM Module,”*IEEE 8th International Conference on Internet Computing and Information Services(IPEC)*, 2007.
- [16] H. G. Rodney, C. H. Lee and V. H. Mok, “Automatic Power Meter Reading System using GSM Network *Proc. of IEEE 8th International power Engineering Coference(IPEC)*, 2007.
- [17]Y. Mengda and Zhu Min, “A Greenhouse Remote Monitoring System Based on GSM,” in *Proc. of IEEE International Conference on Information Management, Innovation Management and Industrial Engineering*,2011.