

# **MODELING OF DSTATCOM USING NON LINEAR LOAD**

**<sup>1</sup>Sunil R. Chavan, <sup>2</sup>Prof.S.S.Hadpe**

<sup>1</sup> PG Scholar ELECTRICAL MCOE&RC Nashik (Pune University)

<sup>2</sup>Assistant Professor ELECTRICAL Dept. MCOE & RC Nashik,(India)

## **ABSTRACT**

*In this paper Distribution Static Compensator (DSTATCOM) which taking into account multi-Level Cascaded H – bridge (CHB) Inverter for minimization of harmonics and compensate reactive power in Power System. This CHB based inverter supply low harmonics distortion, reduced number of switches, suppression of switching losses and take out the Total Harmonics Distortion (THD). It dispense with the Total Harmonics Distortion (THD) drawn from the nonlinear load for example, switch mode power supply (SMPS), uninterruptable power supply (UPS) To improve the control performance of multi sampled multilevel inverter in contrast to the bipolar switched inverter, the small-signal z-domain model is derived. A level shifted PWM (LSPWM) strategy is utilized to investigate the execution of CHB Inverter. The outcomes are load voltage, current, reactive power, active power, power factor and harmonics gotten through Matlab.*

**Keywords: DSTATCOM, LSPWM, SMPS, THD, UPS**

## **I. INTRODUCTION**

In power distribution networks, reactive power is required to maintain the voltage to deliver active power through distribution lines. Conventionally, Static Var Compensators (SVCs) have been used in conjunction with passive filters at the distribution level for reactive power compensation and mitigation of power quality problems. Another compensating system has been proposed by, employing a combination of SVC and active power filter, which can compensate three phase loads in a minimum of two cycles. Thus, a controller which continuously monitors the load voltages and currents to determine the right amount of compensation required by the system and the less response time should be a viable alternative. Distribution Static Compensator (DSTATCOM) has the capacity to overcome the above mentioned drawbacks by providing precise control and fast response during transient and steady state, with reduced foot print and weight. A DSTATCOM is basically a converter based distribution flexible AC transmission controller sharing many similar concepts with that of a Static Compensator (STATCOM) used at the transmission level. At the transmission level, STATCOM handles only fundamental reactive power and provides voltage support, while a DSTATCOM is employed at the distribution level or at the load end for dynamic compensation. The latter, DSTATCOM, can be one of the viable alternatives to SVC in a distribution network. Additionally, a DSTATCOM can also behave as a shunt active filter, to eliminate unbalance or distortions in the source current or the supply voltage, as per the IEEE-519 standard limits. Since a DSTATCOM is such a multifunctional device, the main objective of any control algorithm should be to make it flexible and easy to implement, in addition to exploiting

its multi functionality to the maximum. Prior to the type of control algorithm incorporated, the choice of converter configuration is an important criterion. The two types of converter configurations are voltage source converter and current source converter, in voltage source converter passive storage elements capacitor and in current source inverter an inductor use. Normally, voltage source converters are preferred due to their smaller size, less heat dissipation and less cost of the capacitor, as compared to an inductor for the same rating. This project focuses on the harmonics produces due to nonlinear load and Level shift pulse width modulation (LSPWM) controlling technic are use for the cascaded H bridge inverter.. The following indices are considered for comparison – measurement and signal conditioning requirement, performance with varying nonlinear load, total harmonic distortion (THD), DC link voltage variation, switching frequency and sampling frequency. The project briefly describes the level shift pulse width modulation technic. The project also emphasizes the z domain model is derived to analyse multisampled multilevel inverter of current control technique, as it significantly affects the performance of a DSTATCOM. A dynamic simulation model of the DSTATCOM has been developed in Matlab.

## II. OPERATING PRINCIPLES OF THE D-STATCOM

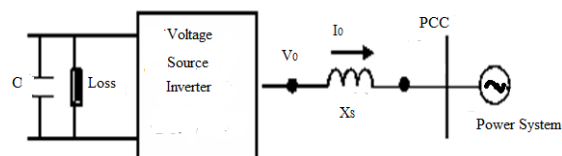

**Fig.1 Single line diagram of the voltage source inverter based DSTATCOM**

Basically, the STATCOM system is comprised of three main parts: a VSI, a set of coupling reactors or a step-up transformer, and a controller. In a very-high-voltage system, the leakage inductances of the step-up power transformers can function as coupling reactors. The main purpose of the coupling inductors is to filter out the current harmonic components that are generated mainly by the pulsating output voltage of the power converters. The single line diagram of the STATCOM system is illustrated in Figure 1. In principle, the exchange of real power and reactive power between the STATCOM and the power system can be controlled by adjusting the amplitude and phase of the converter output voltage. In the case of an ideal lossless power converter, the output voltage of the converter is controlled to be in phase with that of the power system. In the case of an ideal lossless power converter, the output voltage of the converter is controlled to be in phase with that of the power system. In this case, there is no real power circulated in the STATCOM therefore, a real power source is not needed. To operate the STATCOM in capacitive mode or Var generation the magnitude of the converter output voltage is controlled to be greater than the voltage at the PCC. In contrast, the magnitude of the output voltage of the converter is controlled to be less than that of the power system at the PCC on order to absorb reactive power or to operate the STATCOM in inductive mode However in practice; the converter is associated with internal losses caused by non-ideal power semiconductor devices and passive components. As a result without any proper controls the capacitor voltage will be discharged to compensate these losses and will continuously decrease in magnitude. To regulate the capacitor voltage, a small phase shift is introduced between the converter voltage and the power system voltage.

### III. NON LINEAR LOAD

Nonlinear loads used in industries introduce current harmonics at the utility. This causes malfunctioning of the sensitive loads connected at the PCC. Hence harmonic analysis of the nonlinear loads is essential. Computer simulation is the most convenient way of harmonic analysis provided that the system components are modelled accurately and verified either through measurements or mathematically. This can be used for estimating the harmonic currents injected at PCC by an industry. The current and voltages of the industrial loads are nonsinusoidal due to their nonlinear characteristics.

- Personal Computer (PC)

Personal computers are one of the most widely used electronic loads in modern life. It produces harmonic current especially when there is a large concentration of them in a distribution system. It utilizes the switch mode power electronics technology which draws highly non-linear currents that contain large amounts of third and higher order harmonics. A switch mode power supply (SMPS) has a large capacitor which maintains approximately constant voltage for the DC bus in the power supply.

### IV. CONTROL STRATEGIES

Satisfactory performance, fast response, flexible and easy implementation are the main objectives of any compensation strategy. The control strategies of a DSTATCOM are mainly implemented in the following steps:

- Measurements of system variables and signal conditioning
- Generation of firing angles for switching devices

#### I. Pulse Width Modulation (PWM) technic

Two main types of PWM technic are mostly used

- a. Level Shift Carrier PWM
- b. Phase Shifted Carrier PWM

In this project Level Shift Carrier (PWM) technicare use.

- a. Level Shifted Carrier PWM (LSCPWM)

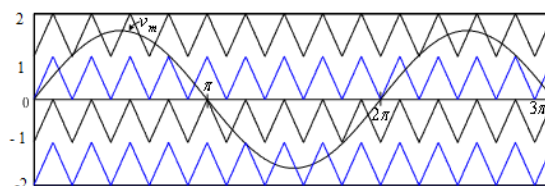

**Fig.2 Level shifted carrier PWM**

Fig.2 Multilevel carrier-based PWM showing carrier bands, modulation waveform, and inverter output waveform. Multilevel inverters by making the use of several triangular carrier signals and one reference signal per phase. For an m-level inverter, m-1 carriers with the same carrier frequency  $f_c$  and same peak-to-peak amplitude  $A_c$  are disposed such that the bands they occupy are contiguous.

The reference, or modulation, waveform has peak-to-peak amplitude  $A_m$  and modulation frequency  $f_m$ , and it is centered in the middle of the carrier set. The reference is continuously compared with each of the carrier signals. If the reference is greater than a carrier signal, then the active device corresponding to that carrier is switched on and if the reference is less than a carrier signal, then the active device corresponding to that carrier is switched off. In multilevel inverters, the amplitude modulation index  $M_a$ , and the frequency ratio  $M_f$ , are defined as

$$M_a = \frac{A_m}{A_c} \quad (1)$$

$$M_f = \frac{f_c}{f_m} \quad (2)$$

For carriers signals, the time values of each carrier waves are set to  $[0 (1/f_s)*1/2 1/f_s]$  while the outputs values are set  $[0 10]$  according to the disposition of carrier waves. After comparing, the output signals of comparator are transmitted to the IGBT.

The carrier waves and the modulating signals are compared and the output of the comparator defines the output in the positive half cycle the comparator output will have the value high, if the amplitude of the modulating signal is greater than that of the carrier wave and zero otherwise. Similarly for the negative half cycle, if the modulating signal is lower than the carrier wave the output of the comparator is high and zero otherwise. In the five-level cascaded multilevel inverter each carrier waveform and sine waveform are compared individually. The each comparator output is given to cascaded multilevel inverter switching devices.

## V. MATLAB/SIMULINK MODELING AND SIMULATION RESULTS

SIMULINK model of DSTATCOM is shown in Fig. 3 It having the blocks is source block, control block, APF block, non linear load block and measurements block. The system parameters for simulation study are source voltage of 415v, 50 Hz AC supply, Source resistance of 0.04 ohm and inductance of 0.5mH, Inverter series resistance and capacitance 5 ohm and 5  $\mu$ F respectively. Load resistance and inductance are chosen as 8 ohms and 100mH respectively.

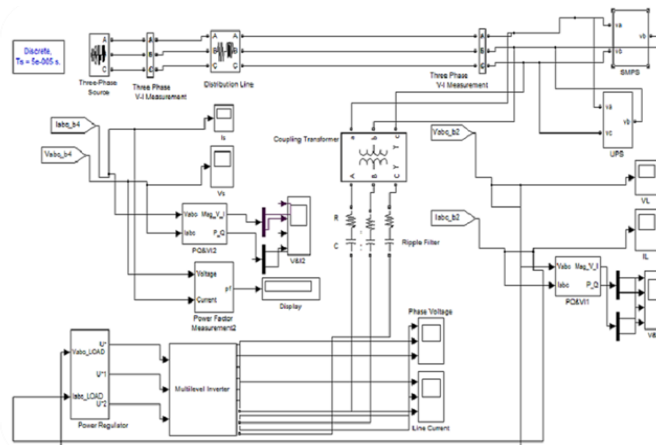

**Fig-3 Matlab / Simulink model of DSTATCOM**

- USE SMPS AS NON LINEAR LOAD

### FFT ANALYSIS

Figure 4 shows that total harmonics distortion without DSTATCOM is 45%

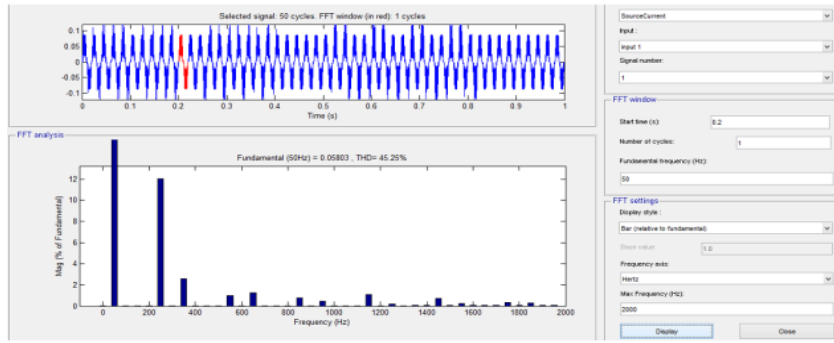

Fig.4 THD without DSTATCOM

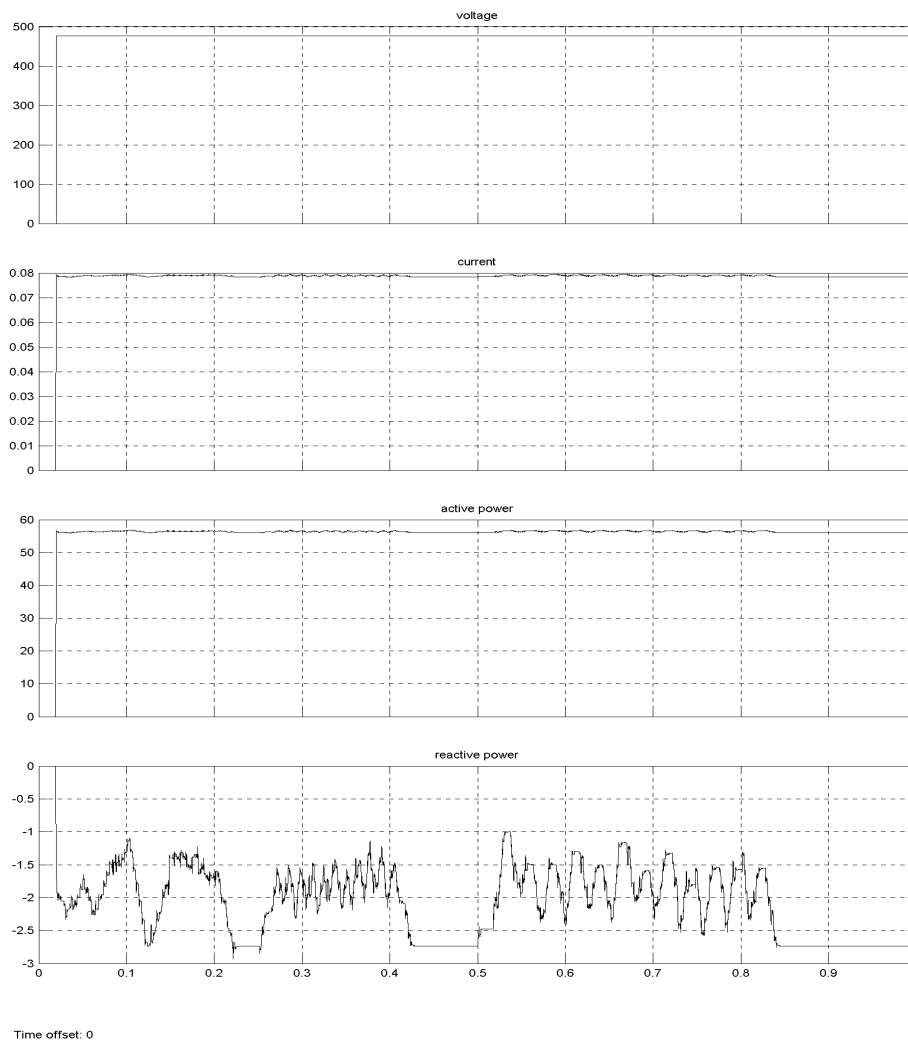

Fig.5 Load Active,Reactive power without DSTATCOM

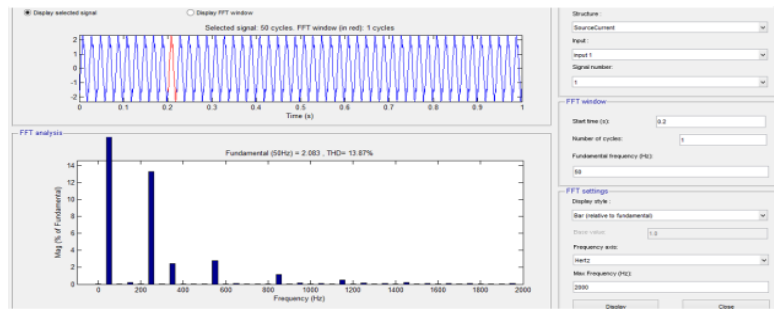

Fig.6 THD with DSTATCOM

Fig.6 shows THD with DSTATCOM is 13%

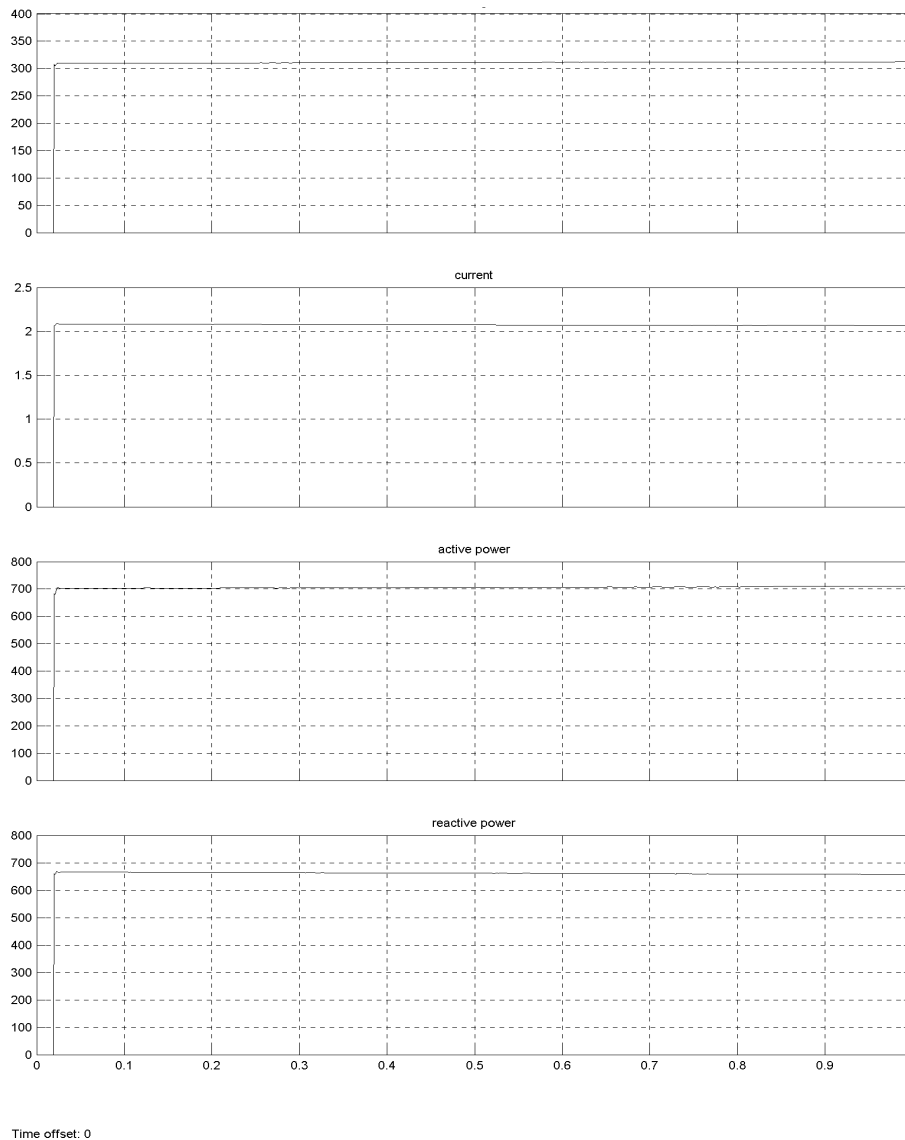

Fig.7 Load Active,Reactive power with DSTATCOM

- USING UPS AS NON LINEAR LOAD

## FFT ANALYSIS

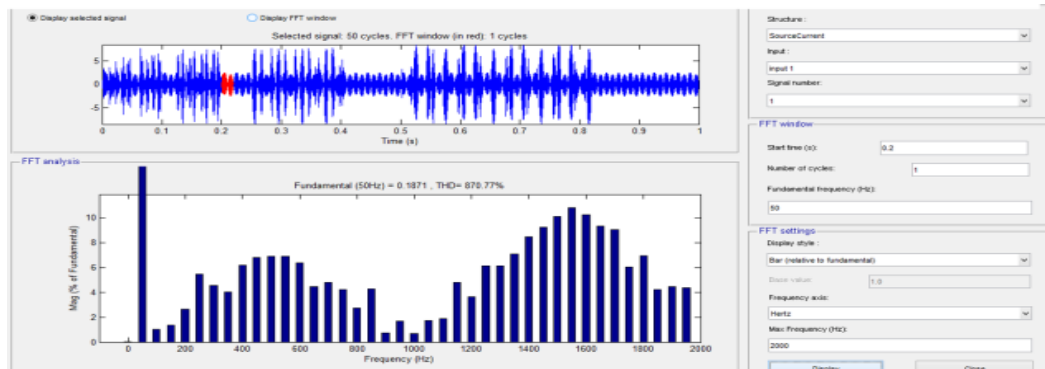

Fig.8 THD without DSTATCOM

Fig.8 shows total harmonics distortion without DSTATCOM is 870%

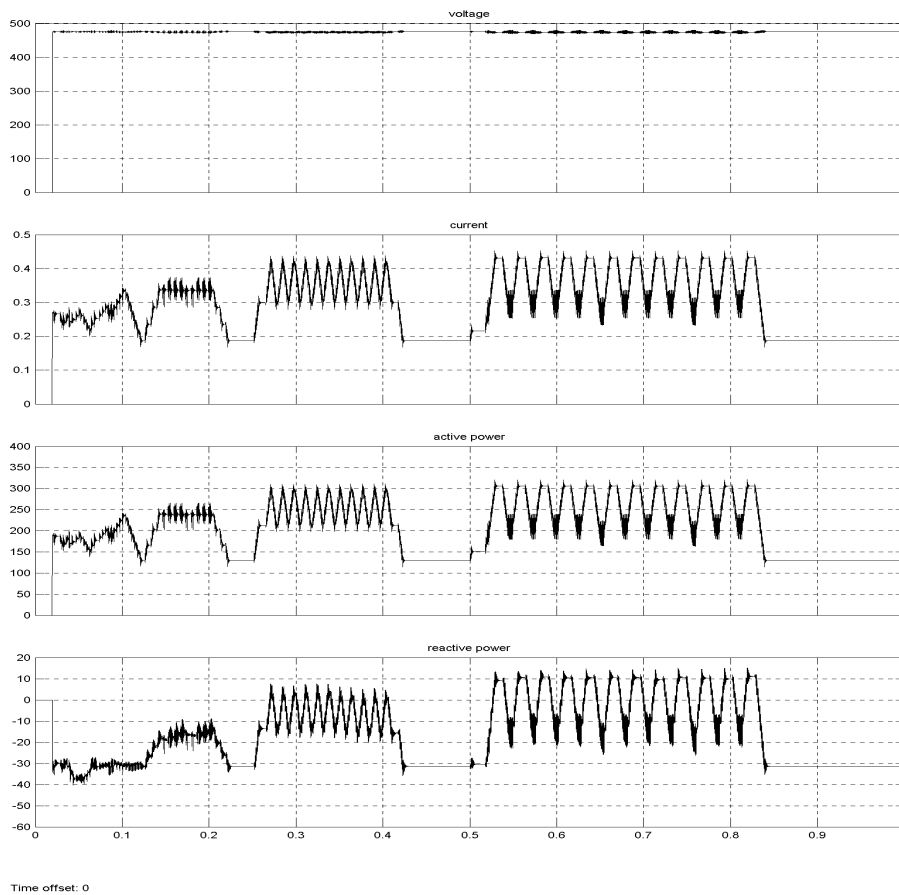

Fig.9 Load Active, Reactive power without DSTATCOM

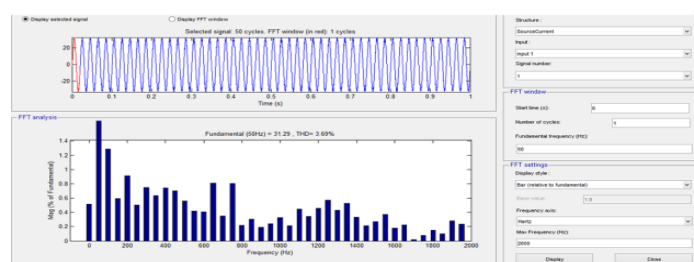
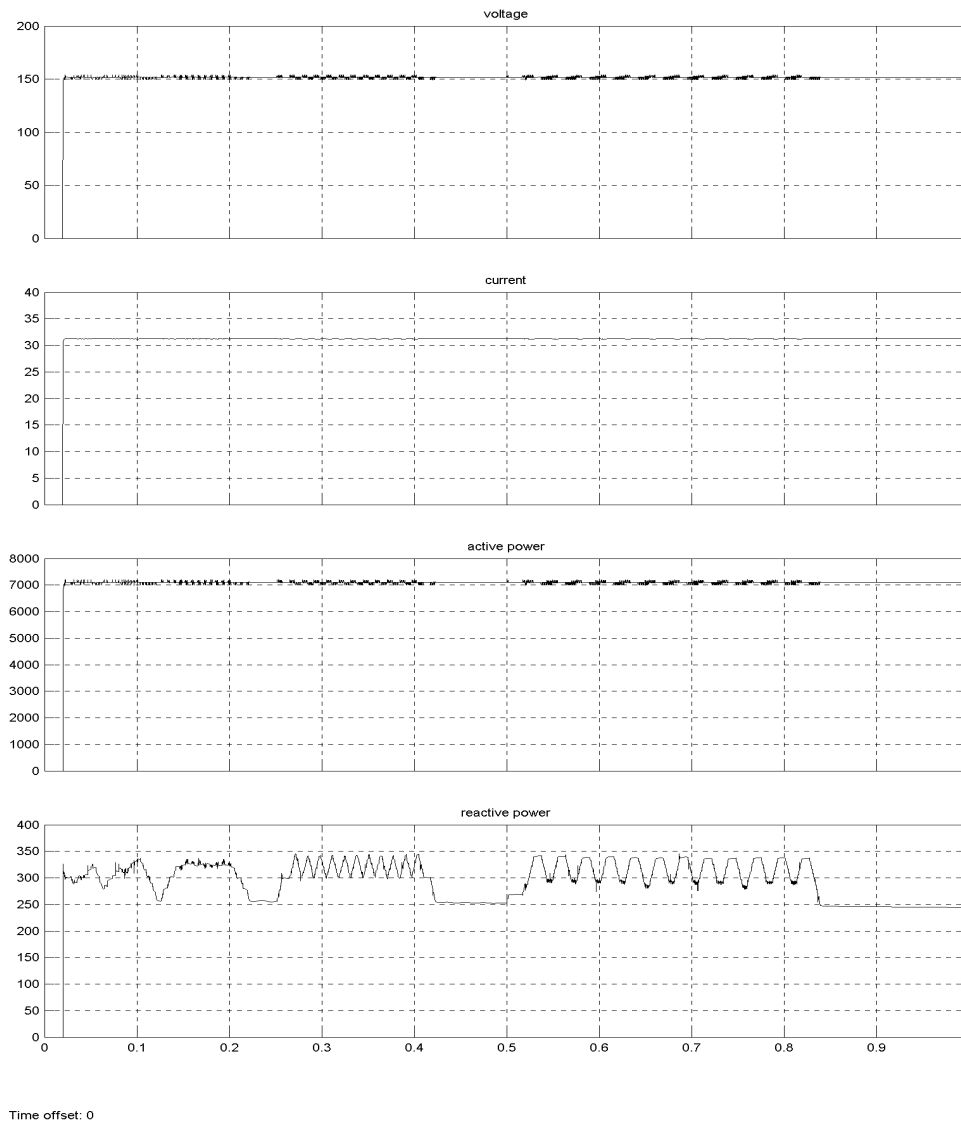

Fig.10 THD with DSTATCOM

Figure 10 shows total harmonics distortion with DSTATCOM is 3.69%



**Fig.11 Load Active, Reactive power with DSTATCOM**

## VI. CONCLUSION

Level shift Pulse width modulation (LSPWM) constructed and assesses its execution DSTATCOM with five level CHB inverter is displayed in this thesis. The source current, source voltage, load current, load voltage, active power, reactive power, recreation comes about under nonlinear load with STATCOM and without STATCOM are displayed. Utilizing multilevel converters to minimize the total harmonics distortion. The reactive power compensate for the stability of the system.



## REFERENCES

- [1]. Gishin Jacob George, Rakesh R., Dr. M. Kowsalya 'Modeling of STATCOM under Different Loading Conditions' IEEE Press ,2012
- [2]. N.G.Hingorani and L.Gyugyi, 'Understanding FACTS-Concepts and Technology of Flexible AC Transmission Systems, IEEE Press, New York, 2000.
- [3]. K.R. Padiyar, 'FACTS Controllers in Power Transmission and Distribution', New Age Publishers ,India, 2007
- [4]. J. Ganesh Prasad Reddy, K. Ramesh Reddy Design and Simulation of Cascaded H-Bridge Multilevel Inverter Based DSTATCOM for Compensation of Reactive Power and Harmonics,1 Intl Conf. on Recent Advances in Information Technology I RAIT-20121
- [5]. Prof. B.S.Krishna Varma, G.Vineesha, J.Trupti kumar, K.Sasank, P. Naga Yarasvi Simulated Control System Design of a Multilevel STATCOM for Reactive Power Compensation IEEE-international Conference On Advances In Engineering, Science And Management (ICAESM -2012) March 30, 31, 2012
- [6]. Leon M. Tolbert, Thomas G. Habetler, Novel Multilevel Inverter Carrier-Based PWM Methods IEEE IAS 1998 Annual Meeting, St. Louis, Missouri, October 10-15, 1998, pp. 1424-1431.
- [7]. Ravilla Madhusudan, G. Ramamohan Rao, Modeling and Simulation of a Distribution STATCOM (D-STATCOM) for Power Quality Problems-Voltage Sag and Swell Based on Sinusoidal Pulse Width Modulation (SPWM), IEEE- International Conference On Advances In Engineering, Science And Management (ICAESM -2012) March 30, 31,2012