

# **STUDY OF DESIGN OF COMPACT HYDRAULIC PRESS MACHINE FOR ROCK DRILL COMPONENTS**

**Nawale Sagar<sup>1</sup> Patil More Tejas<sup>2</sup> Gavande Ajinkya<sup>3</sup> Mistry Girish<sup>4</sup>**

**Vidyasagar Gavali<sup>5</sup>, Chandrashekhar K. Patil<sup>6</sup>**

*<sup>1,2,3,4</sup> B.E. Scholars, Pune University (India)*

*<sup>5</sup>Assistant Professor Mechanical Dept. BVCOE & RI Nashik (India)*

*<sup>6</sup>Principal BVCOE & RI Nashik (India)*

## **ABSTRACT**

*In an attempt to alleviate the problem of the dearth of equipment in our laboratories in most of our higher institutions, a 300bar hydraulic press was designed, constructed and tested using locally sourced materials. The principal parameters of the design included the maximum load, the distance the load resistance has to move (piston stroke, 300 mm), the system pressure, the cylinder area (piston diameter = 150 mm) and the volume flow rate of the working fluid. The major components of the press designed includes the cylinder and piston arrangement, the frame and the hydraulic circuit.*

*The machine was tested for performance with a load of 10 kN provided by two compression springs of constant 9 N/mm each arranged in parallel between the upper and lower platens and was found to be satisfactory. The cost estimate for the hydraulic press was N47,890.00 (US\$320) at prices in Benin City, Nigeria, as at the time of press manufacture.*

## **I. INTRODUCTION**

The development of engineering over the years has been the study of finding ever more efficient and convenient means of pushing and pulling, rotating, thrusting and controlling load, ranging from a few kilograms to thousands of tons (Sumaila 2002). Presses are widely used to achieve this. Presses, as defined by Lange (1975), are pressure exerting machine tools. They can be classified into three principal categories as: hydraulic presses which operate on the principles of hydrostatic pressure, screw presses which use power screws to transmit power and mechanical presses which utilize kinematic linkage of elements to transmit power (Nebel et al. 1989; Degarmo et al. 1997; Sharma 2005). In hydraulic press, the force generation, transmission and amplification are achieved Department of Production Engineering, University of Benin, Benin City, Edo State, Nigeria. Using fluid under pressure. The liquid system exhibits the characteristics of a solid and provides a very positive and rigid medium of power transmission and amplification. In a simple application, a smaller piston transfers fluid under high pressure to a cylinder having a larger piston area, thus amplifying the force. There is easy transmissibility of large amount of energy with practically unlimited force amplification. It has also a very low inertia effect.

A typical hydraulic press consists of a pump which provides the motive power for the fluid, the fluid itself which is the medium of power transmission through hydraulic pipes and connectors, control devices and the hydraulic motor which converts the hydraulic energy into useful work at the point of load resistance (Sumaila

2002; Sharma 2005). The main advantages of hydraulic presses over other types of presses are that they provide a more positive response to changes in input pressure, the force and pressure can accurately be controlled, and the entire magnitude of the force is available during the entire working stroke of the ram travel. AU J.T. 14(3): 196-200 (Jan. 2011) Technical Report 197 Hydraulic presses are preferred when very large nominal force is required (Lange 1975). The hydraulic press is an invaluable equipment in the workshop and laboratories especially for press fitting operations and for the deformation of materials such as in metal forming processes and material testing for strength. A look at the workshop in Nigeria reveals that all such machines are imported into the country. Therefore, it is intended here to design and manufacture a press, which is low cost and hydraulically operated using locally sourced materials. This will not only help to recover the monies lost in the form of foreign exchange, but will enhance the level of our local technology in the exploitation of hydraulic fluid power transmission.

## 1.1 Problem Definition

The problem in the pressing of small components of rock drill machine is that it has to be pressed on high capacity machine which required large amount of power supply, greater pump capacity. Which increases the machine size, its initial as well as running cost.

## 1.2 Solution

- 1) To Reduce the Floor space area required in the Industry .
- 2) The press is Compact and Easy to assemble and dismantle .
- 3) Small parts of Rock drill machines can be easily pressed using this machine .

## 1.3 Objectives

- 1) Manual and hydraulic control
- 2) With cylinder extension
- 3) Pressure gauge in casing
- 4) Supplied with hoisting eye
- 5) Compact mode

## II. THEORY OF HYDRAULIC PRESS

### 2.1 Principle:

The hydraulic press depends on Pascal's principle: the pressure throughout a closed system is constant. One part of the system is a piston acting as a pump, with a modest mechanical force acting on a small cross-sectional area; the other part is a piston with a larger area which generates a correspondingly large mechanical force. Only small diameter tubing (which more easily resists pressure) is needed if the pump is separated from the press cylinder. Pascal's law: Pressure on a confined fluid is transmitted undiminished and acts with equal force on equal areas and at 90 degrees to the container wall. A fluid, such as oil, is displaced when either piston is pushed inward. Since the fluid is incompressible, the volume that the small piston displaces is equal to the volume displaced by the large piston. This causes a difference in the length of displacement, which is proportional to the ratio of areas of the heads of the pistons given that  $\text{Volume} = \text{Area} \times \text{Length}$ . Therefore, the small piston must be

moved a large distance to get the large piston to move significantly. The distance the large piston will move is the distance that the small piston is moved divided by the ratio of the areas of the heads of the pistons. This is how energy, in the form of work in this case, is conserved and the Law of Conservation of Energy is satisfied. Work is force applied over a distance, and since the force is increased on the larger piston, the distance the force is applied over must be decreased. Bramah's basic idea is also exploited in hydroforming.

## 2.2 Working

Since the hydraulic press works on the basis of Pascal's Law, its working is similar to the one of the hydraulic system. A hydraulic press consists of basic components used in a hydraulic system that includes the cylinder, pistons, the hydraulic pipes, etc. The working of this press is very simple. The system comprises of two cylinders, the fluid (usually oil) is poured in the cylinder having a small diameter. This cylinder is known as the slave cylinder. The piston in this cylinder is pushed so that it compresses the fluid in it that flows through a pipe into the larger cylinder. The larger cylinder is known as the master cylinder. The pressure is exerted on the larger cylinder and the piston in the master cylinder pushes the fluid back to the original cylinder. The force applied on the fluids by the smaller cylinder results in a larger force when pushed in the master cylinder. The hydraulic press is mostly used for industrial purposes where a large pressure is required for compressing metals into thin sheets. An industrial hydraulic press uses the material to be worked upon along with the help of the press plates to crush or punch the material into a thin sheet.

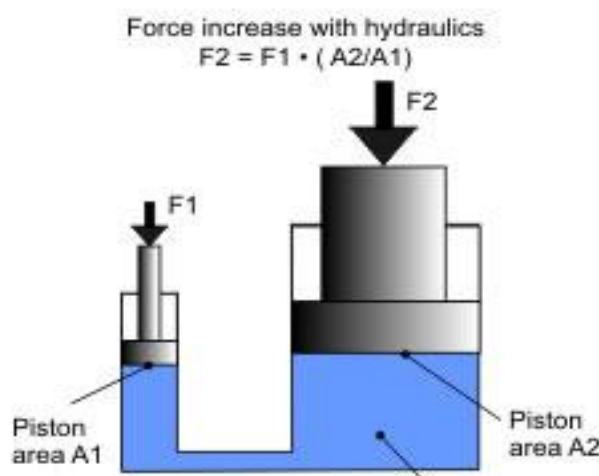

Fig.No.1-Pascal's law

## 2.3. Types of Hydraulic Press:

There are many different types of hydraulic presses catering to the various requirements of industries. Some of them are as follows:

**1) Arbor presses:** These presses are usually used when the work involved is not of a heavy-duty nature. These presses come in a variety of sizes and specifications. But compared to other hydraulic presses, they do not compress large amounts of pressure required to generate more output. Arbor presses are used in processes like piercing holes into metals, stamping, to flatten metals, tearing, marking inscriptions, etc.

**2) Laminating presses:** Unlike other hydraulic presses that are operated automatically, these presses make use of manual labor. Laminating presses have two openings that are known as plates. One is used for heating whereas the other is used for cooling. This makes the lamination process comparatively faster. Through these presses, materials like polymer can be laminated onto paper and metal. In case of laminating presses, the plates are usually heated with oil or through electricity. A laminating press is also used for common uses such as laminating the identity cards, certificates and even book covers. In this way, laminating presses facilitates fast and easy lamination for industrial and domestic needs.

**3) C- frame presses:** These presses have a 'C' like shape, which is specifically designed to maximize the floor space for the workers in order to move around easily at the workplace. Unlike other presses that have multi-processes, the C- frame presses only include a single press application. Its application includes straightening, drawing and mostly includes assembling work. C- frame presses come in a variety of weights. The C- frame presses are also available with extra features such as wheel stands and pressure gauges.

**4) Pneumatic presses:** These presses are the most basic hydraulic presses used in industries because they compress the air to create a pressure in order to gain movement. The advantage of pneumatic presses is that the operations are performed fast whereas the disadvantage of this press is that it cannot create extremely high pressures, as other hydraulic presses are able to create. The pneumatic presses are often used in car and aircraft brakes system. The industrial uses of pneumatic presses would include assembling, drawing, punching, etc. A pneumatic press usually requires a full time operator and for the sake of his safety, additional safety accessories such as electrical safety devices are also included.

**5) Power presses:** These presses are used in large industries that demand the use of heavy machinery and equipments. There are 2 kinds of power presses on the basis of the type of clutch used. They are full revolution and part revolution clutch. In case of a full revolution clutch, the clutch cannot be disrupted until and unless the crankshaft makes a full revolution. In case of part revolution, the clutch can be disrupted at any time, before or after the full revolution. Power presses involve a lot of danger because of the heavy operations associated with it. A lot of safety measures are taken while using power presses.

**6) Assembly presses:** These presses use the extreme pressure generated by the pistons and the hydraulic fluids to assemble and maintain the parts.

**7) H- frame presses:** These presses have a peculiar 'H' shape and are capable of handling more than one press application.

## 2.4. Properties And Specification

### 2.4.1 Properties

- 1) Manual and hydraulic control
- 2) With cylinder extension
- 3) Pressure gauge in casing
- 4) Supplied with hoisting eye
- 5) Pump with year guarantee
- 6) Compact mode

## 2.4.2 Specification

Motor power	1HP
Press load	30 Tons
Max. pressure	200-300 bar
Cylinder stroke	300 mm
Oil feed	5 l/min
Oil tank capacity	30 ltr
Down speed	5 mm/s
Return speed	6 mm/s
Diameter cylinder	70 mm
Diameter piston head	30 mm
Working width	750 mm
Net weight	450 kg
Voltage	400 V

Table No.1 SpecificationsTable

## 2.5 Safety Measures And Benefits Of The Hydraulic Press

### 2.5.1 Safety Measures

As of today, hydraulic presses are available in both the categories, i.e., automatic and manually operated. In case of manually operated hydraulic presses, many safety measures have to be taken such as using interlocking and barrier guards.

### 2.5.2 Benefits Of the Hydraulic Press

Unlike their mechanical counterparts, hydraulic presses can compress any material to a full extent. Also, hydraulic presses take only half of the space that the mechanical ones take because they have the ability to compress a large pressure in a cylinder having a less diameter.

## 2.6 The Function Of The Hydraulic System

Hydraulic systems convert electrical energy into hydraulic energy, which in turn is transformed into mechanical energy with the aid of the individual hydraulic cylinders inside the press. The hydraulic fluid in the cylinders actuates the press slide as follows:

- 1) Forces are generated through the action of the hydraulic fluid.
- 2) Displacements are achieved by the supply of hydraulic fluid.
- 3) Press (slide) speed is proportional to volumetric flow rates.
- 4) Forward and reverse motions are controlled by the direction of fluid flow.

## III. DESIGN METHODOLOGY

Fluid power systems are designed by objective (Sullivan 1975). The primary problem to be solved in designing the system is transposing the desired performance of the system into system hydraulic pressure and The

principal parameters of the design included the maximum load (300 kN), the distance the load resistance has to move (piston stroke, 150 mm), the system pressure, the cylinder area (piston diameter = 100 mm) and the volume flow rate of the working fluid. The critical components that require design included the hydraulic cylinder, the frame, the hydraulic circuit.

### 3.1. Component Design

#### 3.1.1. Hydraulic Cylinder:

Hydraulic cylinders are tubular in structure in which a piston slides when hydraulic fluid is admitted into it. The design requirement includes the minimum wall thickness of the cylinder, the end cover plate, the flange thickness and the specification and selection of number and sizes of bolts. The output force required from a hydraulic cylinder and the hydraulic pressure available for this purpose determine the area and bore of the cylinder and the minimum wall thickness. From Khurmi and Gupta (1997), the maximum wall thickness,  $t$  of a pressure vessel (hydraulic cylinder) was computed to be 0.0167 m from Eq. (1) below:

$$t = R_i \{ [\delta_t / (\delta_t - 2p)]^{1/2} - 1 \}, \quad (1)$$

where:

$R_i$  = internal radius of cylinder (m),  $50 \times 10^{-3}$  m;

$p$  = Internal fluid pressure ( $\text{N/m}^2$ ), 3.82;

$\delta_t$  = Tangential stress ( $\text{N/m}^2$ ),  $480 \times 10^6$ .

Therefore a minimum wall thickness of 0.017 m was considered adequate for the design.

#### 3.1.2. Cylinder End-Cover Plate:

The thickness  $T$ , of the end-cover-plate, which is supported at the circumference by bolts and subjected to an internal pressure uniformly distributed over the area, is given by Eq. (2) from Khurmi and Gupta (1997), as:

$$T = KD(P / \delta_t)^{1/2}, \quad (2)$$

where:

$D$  = Diameter of end cover plate (m), 0.1;

$K$  = Coefficient depending upon the material of plate, 0.4, from Khurmi and Gupta (1997);

$P$  = Internal fluid pressure ( $\text{N/m}^2$ ), 38.2;

$\delta_t$  = Allowable design stress of cover. Plate material, 480  $\text{N/m}^2$ ; from which the thickness of the plate was obtained to be 0.0118 m.

#### 3.1.3. Bolt:

The cylinder cover may be secured by means of bolts or studs. The possible arrangement for securing the cover with bolts is shown in Fig. 2. In order to find the correct size and number of bolts,  $n$ , to be used, the following Eq. (3) was used as adopted from Khurmi and Gupta (1997):

$$(\pi D_i^2 / 4) P = (\pi d_c^2 / 4) \delta_{tb} n, \quad (3)$$

where;

$P$  = Internal fluid pressure ( $\text{N/m}^2$ );

$D_i$  = Internal diameter of cylinder (m);

$d_c$  = Core diameter of bolt (m),  $16 \times 10^{-3}$  m;

$\delta_{tb}$  = Permissible tensile strength of the bolt.

If the size of the bolt is known, then, the number of bolts can be computed from Eq. (3) and vice versa. However, if the value of  $n$  as obtained from Eq. (3) above is odd or a fraction, then the next higher even number is adopted. The number of bolts was computed to be 3.108, hence four bolts were chosen. The tightness of the joint between the cylinder and the end-cover-plate depends on the circumferential pitch,  $D_p$ , of the bolt, which was obtained as 0.0191 m from Eq. (4):

$$D_p = D_i + 2t + 3D_c, \quad (4)$$

where:

$t$  = thickness of cylinder wall (m),  $17 \times 10^{-3}$ .

#### 3.1.4. Cylinder Flange:

The design of cylinder flange is essentially to obtain the minimum thickness  $t_f$  of the flange, which may be determined from bending consideration. There are two forces in action here, one due to fluid pressure and the other that tends to separate the flange due to sealing which has to be resisted by the stress produced in the bolts. The force trying to separate the flange was computed to be 58.72 kN from Eq. (5):

$$F = (\pi/4)D_1^2P, \quad (5)$$

where:

$D_1$  = outside diameter of seal,  $134 \times 10^{-3}$  m.

#### 3.1.5. Flange Thickness Determination:

The thickness of the flange,  $t_f$  may be obtained by considering the bending of the flange about section A-A being the section along which the flange is weakest in bending (Fig. 3). This bending is brought about due to the force in two bolts and the fluid pressure inside the cylinder. Therefore, Eq. (6) gave a flange thickness of 0.0528 m:  $t_f = (6M)/(b \delta_f)$ , (6)

where:

$b$  = Width of flange at section A-A,  $22.2 \times 10^{-3}$  m;

$\delta_f$  = Shear stress of flange material, 480 N/m<sup>2</sup>;

$M$  = Resultant bending moment, 5,144.78 Nm.

#### 3.1.6. Piston:

The required piston rod column size necessary to sustain applied load and which is in alignment with the center line the cylinder bore is influenced by the strength of the rod material, the force applied to the rod column in compression, the mounting situation of the cylinder itself and the stroke over which the load is to be applied. The procedure for computing piston rod column size and cylinder lengths under end AU J.T. 14: 196-200 (Jan. 2011) Technical Report 199 thrust condition was accomplished using the procedure suggested by Sullivan (1975). By this the size of the piston rod of diameter not less than 0.09 m was considered adequate for the design.

#### 3.1.7. Selection of Seals:

Seals are used to prevent internal and external leakages in the system under varying operating conditions of pressure and speed. Static seal selected uses the groove and ring principle to affect a seal. The groove dimension is calculated such that the Oring selected is to be compressed 15-30% in one direction and equal to 70-80% of the free cross-sectional diameter. The problem



in the selection of static seal is to specify the groove such that an O-ring can be compressed in one direction and expanded in another, Therefore; a

groove dimension of 4 mm × 3 mm was specified for the seal.

### 3.2. Frame Design

The frame provides mounting points and maintains proper relative positions of the units and parts mounted on it over the period of service under all specified working conditions. It also provides general rigidity of the machine (Acherkan 1973). The design consideration is that of direct tension imposed on the pillars. Other frame members such as the platens (as in our case) are subjected to simple bending stresses.

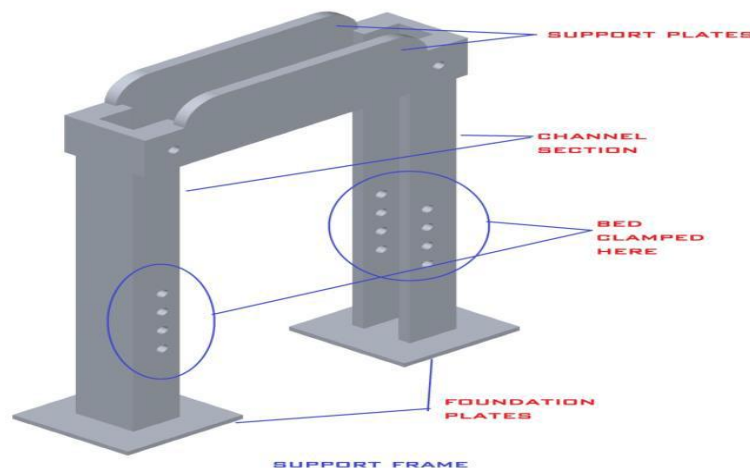

Fig.No.2-Frame design

#### 3.2.1. Platen:

The upper and lower platens provide point of direct contact with the object being compressed. Hence, they are subjected to pure bending stress due to an equal and opposite couple acting in the same longitudinal plane. The design consideration is essentially for bending and consists primarily upon the determination of the largest value of the bending moment ( $M$ ) and shear force ( $V$ ) created in the beam which was found to be 45 kN/m and 150 kN, respectively. These were computed using the procedure adopted from Beer and Johnston (1992).

#### 3.2.2. Section Modulus:

The values of  $V$  and  $M$  obtained facilitate the computation of the modulus of section of the platens. This gives the minimum depth (thickness)  $d$ , and was computed to be 0.048 m from Eq. (7):  $d = [(6M)/(\delta b)]^{1/2}$ , (7)

where;

$M$  = Maximum bending moment, 45 kN/m;

$b$  = 600 × 10<sup>-3</sup> m;

$\delta$  = 480 × 10<sup>6</sup> N/m<sup>2</sup>.

#### 3.2.3. Pump:

The initial parameter in the design is to estimate the maximum fluid discharge pressure required at the cylinder and a factor is then added to account for frictional loss in the system. This was obtained to be 47.16 × 10<sup>6</sup> N/m<sup>2</sup>.



The pumping action is actuated by a lever system. The actual length of the lever was obtained to be 0.8 m. This was calculated by assuming a maximum theoretical effort and taking moment about the fulcrum.

### 3.4. Die

Die is an integral part of any manufacturing process which enables the desired shape that one require. Here for the experimental purpose a compound die have been used which produces a washer from the strip of sheet metal. The dimensions of the outcome washers are as follow. Outer diameter = 30 mm , Inner diameter = 10 mm. A blanking die produces a flat piece of material by cutting the desired shape in single operation. The finished part is referred to as a blank. Generally a blanking die may only cut an outer contour of part, often used for parts with no internal features.

### 3.5 Bed

Bed is a plate on which the die is supposed to held. It is used for mounting the die on support frame at desired position. Figure 3 shows the design of bed where the holes produced on the sides shows the support plate to be clamped on support frame.

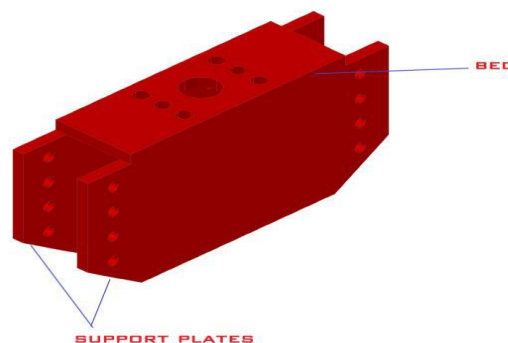

Fig.No.3-Bed design

## IV. ADVANTAGES AND DISADVANTAGES

### 4.1 Advantages

- 1) Compact in shape and size.
- 2) Equipment handling is easy.
- 3)The press machine less bulky compare to other machine.
- 4) The simplicity and easy to repair design makes it really cheap

### 4.2 Disadvantages

- 1) Only small component manufacturing.

## V. CONCLUSION

A 300bar hydraulic press was designed, manufactured, and calibrated. The machine was tested to ensure conformability to design objectives and serviceability. The machine was found to be satisfactory at a test load of 10 kN

# International Conference On Emerging Trends in Engineering and Management Research

NGSPM's Brahma Valley College of Engineering & Research Institute, Anjaneri, Nashik(MS)

(ICETEMR-16)

23rd March 2016, [www.conferenceworld.in](http://www.conferenceworld.in)

ISBN: 978-81-932074-7-5

Thus here a hydraulic system is used to develop a press. The press will be useful for massproduction of rock drill components. This may increase the productivity and increases the accuracy of the production. Event the press can be completely automatized by using the concept of ectro-hydraulics. Direction control valve can be solenoid acted to make the system close loop which may lead to higher production rate.

## REFERENCES

[www.google.com](http://www.google.com)

- [1] Acherkan, N. 1973. Machine tool design. Vol. 3, Mir Publ., Moscow, Russia.
- [2] Beer, F.P.; and Johnston, E.R., Jr. 1992. Mechanics of materials. 2nd ed., McGraw- Hill, London, England, UK.
- [3] Dagwa, I.M.; and Ibadode, A.O.A. 2005. Design and manufacture of automobile diskbrake pad test rig. Nigerian Journal of Engineering Research and Development 4(3): 15-24.
- [4] Degarmo, E.P.; Black, J.T.; and Kohser, R.A. 1997. Materials and processes inmanufacturing. 8th ed., Prentice-Hall of India, New Delhi, India, pp. 546-52.
- [5] Khurmi, R.S.; and Gupta, J.K. 1997. A textbook of machine design. Eurasia Publ.,New Delhi, India.