

# **TRAIN WHEEL OPERATED DOOR OPERATION SYSTEM**

**Bhoye Anil Dharmaraj<sup>1</sup>, Gangode Manohar Baburao<sup>2</sup>,  
Bagul Rahul Shamrao<sup>3</sup>, Chaudhari Bhushan Jibhau<sup>4</sup>  
Prof. K. G. Patel<sup>5</sup>**

<sup>1,2,3,4</sup> *BVCOE & RI Nashik B.E.Mechanical Pune University,(India)*

<sup>5</sup> *Assistant Professor Mechanical Dept. BVCOE& RI Nashik.,(India)*

## **ABSTRACT**

*Locomotive is any type of self-propelled vehicle used by railroad to pull or push other type of rolling stock, including passengers, freight. An India is an extensive country. Now day's railway playing a vital role in transport of freight and passengers. Trains are the veins of are country. Indian railway network is one of the largest railway network in the world. Today the growth is phenomenal and the network have a route length of 62,458 Km, with 7116 station. It has fleet of 8268 locomotive 29,501 Coaches, 3291 Electronic multiple units & 3, 46,394 wagons. Today energy conservation is the need of every industry, transportation field. So we have taken challenge to make project in this Train field to support energy conservation system.*

## **I. INTRODUCTION**

Locomotive is any type of self-propelled vehicle used by railroad to pull or push other type of rolling stock, including passengers, freight. An India is an extensive country. Now day's railway playing a vital role in transport of freight and passengers. Trains are the veins of are country. Indian railway network is one of the largest railway network in the world. Today the growth is phenomenal and the network have a route length of 62,458 Km, with 7116 station. It has fleet of 8268 locomotive 29,501 Coaches, 3291 Electronic multiple units & 3, 46,394 wagons. Today energy conservation is the need of every industry, transportation field. So we have taken challenge to make project in this Train field to support energy conservation system.

## **II. CONSTRUCTION**

The construction of Train wheel operated compressor is very simple & compact. Basically it is assembly of Base frame Wheel, Piston-Cylinder, and Air reservoir.

- **Base Frame**

Base frame is made of Fabrication angle. Supported angles are joint under base frame, where the motor & valve is located. Then piston supporter is mounted. Use : The use of the base frame is to give Support & Stability to all project components.

- **Wheel**

By gas cutting a round shape locomotive wheel is made. Then rolling shaft is attached at the centre line of wheel & connecting rod is fixed at the periphery of wheel. Use : To give power and Rotary motion to Connection rod.

- **Air Tank**

Air tank is made of Mild steel. A hole is drilled at the upper side & threading is done to keep the pressure gauge, Then fix two ends using welding & make an input & output air connection. All pressurize air come in tank from various cylinders through the pipe connection. Use : To store pressurize compressed air & supply this pressurize air for various use when required.

- **Air Piston Utiliser**

Air Piston utilize is fitted on frame by using the nut & bolts, at the backside of door. This Air piston utilize is run by pressurize air that come from lever control valve, Which is used to control air, come from Air tank. Use:  
- To operate door, windows.

- **DOOR**

The door is opened & closed on the base frame at the centre. A piston connection is given at the backside of the door due to which the door moves in both directions. Use : For comfort entry & exit to public.

### III. WORKING

The train wheel operated compressor for various systems is work on **law of energy conservation**. The law states that “ energy neither can be created nor destroy but it may transform from one form of energy to another, so sum of energy in its various forms remains constant in the universe.” As the train starts moving, the wheel starts rotating. The connecting rod that is fixed on the periphery of the wheel also starts to rotate with wheel. This rotary motion is further converted in to reciprocating motion with the help of piston cylinder arrangement that is connected at the other end of the connecting rod. When piston start reciprocating in the cylinder t creates suction as it moves towards (B.D.C.) Bottom dead centre, air enter in the cylinder from one hole which is provided with a N.R.V. & when the piston moves towards (T.D.C.), it compresses the air and this operation is continuous and discharge is obtained in air reservoir tank. When we operate lever control valve, air come from air reservoir tank to Air piston utilize. This Pressurize air pushes & Pull to the piston in reciprocating motion causes the opening & closing of the Door.

### IV. FLUID POWER

Fluid power system is a power transmission system in which the transmission of power takes place through a fluid medium. Such a system avoids the mechanical linkages such as gears, belts, ropes, chains etc. to a great extent of a conventional power transmission system. The transmission of power by fluid power system is most convenient and highly efficient. Due to this, the present conventional transmission systems are being replaced and changed over to fluid power based systems.

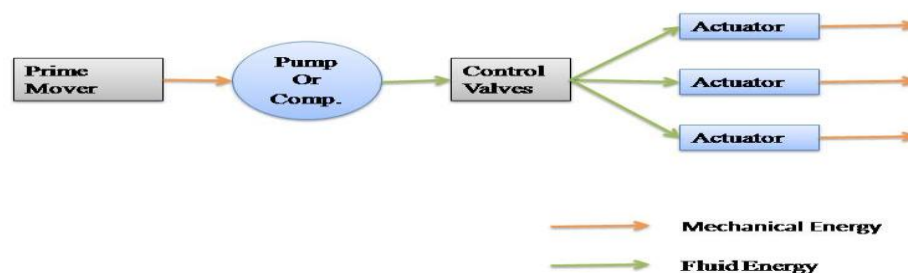

Prime mover supplies the mechanical energy to a pump or compressor which is used to pressurize a fluid. The mechanical energy supplied by the prime mover is converted into the pressure energy by the pump and it is stored in a fluid. The pressurized fluid is now transmitted to different parts of the system through special pipings or tubings. The various parameters such as pressure and flow rate of the fluid can be controlled by using various control valves. At the desired places of use, the fluid energy is converted back into mechanical energy by the devices called actuators consisting of cylinders, motors etc. Thus the energy supplied by the prime mover has been transmitted conveniently through fluid medium to various places and at these places; the mechanical energy has been recovered back in a more convenient form. Since the power is transmitted through the fluid as a medium, therefore such a system is called as fluid power system.

## V. HISTORY OF FLUID POWER

In history long ago, man has recognized and accepted fluids as a source of power. This is quite evident from the fact that in olden days simple machines like Pelton wheel were developed to transmit irrigation water or water head was used to transmit the power. In recent times, engineers started using fluids for power transmission and basic elements like pumps, control valves, cylinders, etc. were experimented and perfected. Slowly oil hydraulics and pneumatics assumed a place of importance in areas of power generation and replaced many mechanical elements like line shafts, chains, gear boxes, electric drive motors etc., in various mechanical systems. In industries, fluid power is used for various purposes. Because of this a new branch is developed called as 'Industrial fluid power'. Now a day in industries, material Handling is the field where fluid power is used in a really big way. It includes cranes of very high capacity, forklifts. Such huge crane handled by a single miniature control valve by an operator. Huge material handling trucks, tippers, loaders dumpers, all make use of hydraulic/pneumatic systems. In addition to the main system of loading/unloading hydraulic and pneumatic components are used in brake systems, clutch systems etc. for their efficient operation.

## VI. COMPARISON OF HYDRAULIC AND PNEUMATIC SYSTEM

No	HYDRAULIC SYSTEM	PNEUMATIC SYSTEM
1	Working fluid is a liquid.	Working fluid is a gas.
2	Works at very high pressure.	Works at low pressure.
3	Working fluid is incompressible.	Working fluid is compressible.
4	Very high forces could be developed.	Only Moderate forces can be developed
5	System is more compact.	It is more bulky.
6	Self lubricating effect.	No self lubricating effect.
7	Several Mechanical movements could be achieved.	Movement is limited.
8	Return line is required for oil.	No reserve oil hence no return line.
9	Frequent replacement of oil required	No need for fluid replenishment.
10	Heavy tubes /pipes are needed.	Light tubing/piping is sufficient.
11	Fire hazard .	No fire hazard.
12	Mess and dirt due to oil.	Clean system due to air.

## VII. PNEUMATIC SYSTEM

### INTRODUCTION

Pneumatic systems form the most primitive and distinct class of mechanical control engineering. They are classified under the term 'Fluid Power Control', which describes any process or device that converts, transmits, distributes or controls power through the use of pressurized gas or liquid. In a pneumatic system, the working fluid is a gas (mostly air) which is compressed above atmospheric pressure to impart pressure energy to the molecules. This stored pressure potential is converted to a suitable mechanical work in an appropriate controlled sequence using control valves and actuators. Pneumatic systems are well suited for the automation of a simple

repetitive task. The working fluid is abundant in nature and hence the running and maintenance cost of these systems are exceptionally low. All fluids have the ability to translate and transfigure and hence pneumatic systems permit variety of power conversion with minimal mechanical hardware. Conversion of various combinations of motions like rotary-rotary, linear-rotary and linear-linear is possible. The simplicity in design, durability and compact size of pneumatic systems make them well suited for mobile applications. These features make them versatile and find universal applications including robotics, aerospace technology, production and assembly of automotive components (power steering, chassis and engine assembly), CNC machines, food products and packaging industry, bomb deployment units and fabrication process of plastic products.

## VIII. HISTORY OF PNEUMATIC SYSTEM

For thousands of years, man has used air as an aid in doing various tasks, e.g. a bellows for lighting fires. In the year 260 BC, a Greek called Ctesibios built the first air gun. In addition to a tight sinew, he used air compressed in a cylinder to increase the range of projectiles. So it is not surprising that "pneuma", the Greek word for "air", has given its name to the technology known as pneumatics. During the industrialization process in the 19th century, machines powered by compressed air were used for mining and building roads. Pneumatic technology has become indispensable in modern industry. Pneumatically powered machines and robots are to be found in numerous industrial processes such as assembling or arranging components, or packing finished goods.

### 8.1 Why We Used Compressed Air Pneumatic System ?

We used pneumatic system, as it has some advantages over the hydraulic system. There is no need for fluid replenishment. Light tubing/piping is sufficient. There is no fire hazard. But in our pneumatic system, we have used air as a working fluid. Because air has the some advantages over the other gases. Properties of air are very suitable for pneumatic system.

#### • Properties of Air:

Air is a mixture of 78% nitrogen, 21% oxygen and 1% other inert gases with moisture by volume. Air exerts pressure at sea level of about 1.013 bar (14.7 psi ) called atmospheric pressure. It is equivalent to 760 mm of Hg or 10.3 m of water pressure as measured by U-tube manometer. Other physical properties of air are:

1. Molecular mass,  $M = 28.96 \text{ kg/kg mol.}$
2. Boiling point at 1 bar =  $-191^\circ \text{ C to } -194^\circ \text{ C.}$
3. Freezing point at 1 bar =  $-212^\circ \text{ C to } -216^\circ \text{ C.}$
4. Characteristic gas constant,  $R = 287 \text{ Nm/kg K.}$

#### • Advantages of Compressed Air Pneumatic Systems:

1. Freely available from the atmosphere.
2. Explosive proof. No protection against explosion required.
3. Easily transportable in the vessels and pipes.
4. No return lines are required.
5. Clean system. It has self cleaning properties.
6. Simple construction and ease of handling.
7. Unduplicated exhaust clear air which escapes through leaking pipe or components don't cause contamination.

8. The pressure, speed and forces required can be controlled easily..

9. Overload safety- Pneumatic tools and operating components can be loaded to the point of stopping and are therefore overload safe

10. Air enables high working speed to be obtained

11. Low cost of maintenance.

### • Disadvantages of Compressed Air System:

1. It is inaccurate in operation.

2. High forces can not be transmitted.

3. It provides non-uniform speeds.

4. Creates noise pollution.

5. Expensive.

6. Conditioning of air is needed.

### Applications:

Usually air at low pressures in the range of 5 to 7 bar is used in pneumatic systems. Compressed air systems are used for many industrial applications. Some of its applications are:

1. To operate pneumatic tools

2. Spray Painting

3. Refrigeration and air conditioning systems

4. Gas turbine power plants

5. Supercharging of I.C Engines

6. Conveying materials like sand and concrete, coal mixtures etc. in pipe line

7. Pumping of Water

8. Driving the mining machinery

9. In Blast furnaces

10. In Robotics

## IX. WORKING

### Basic principle of pneumatic system:

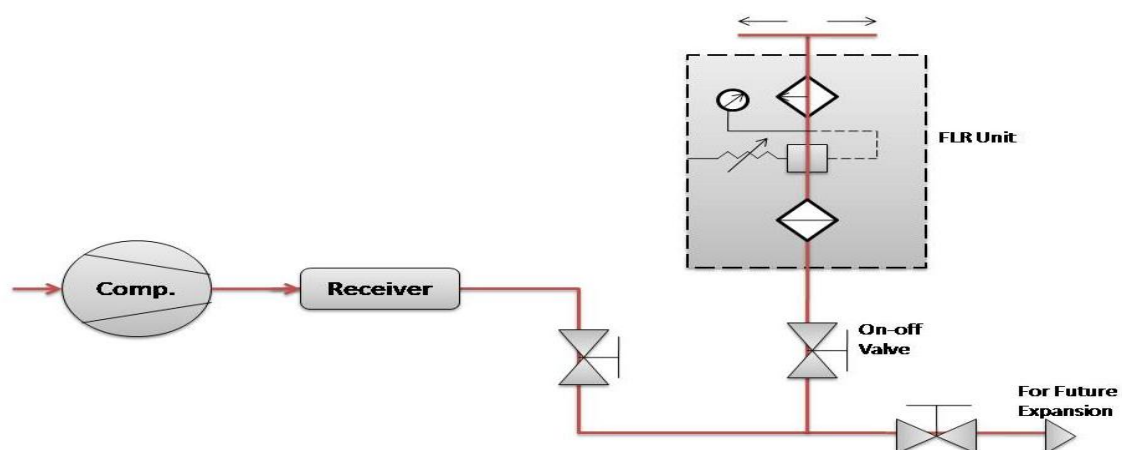

## • Basic Pneumatic System

The basic layout of a pneumatic system is shown in fig.. it could be observed that the basic components involved are similar to a hydraulic system. The basic differences between hydraulic and pneumatic systems are that in hydraulic system the input mechanical energy is imparted to the oil is by pump, whereas, in pneumatic systems the working fluid being air, the mechanical energy is imparted to air by a compressor. Further, a hydraulic system usually operates at very high pressures to transmit the large force and power while a pneumatic system operates at low pressures of about 5 – 7 bar for industrial applications.

The major components of the pneumatic systems are:

1. A compressor of appropriate capacity to meet the compressed air requirements.
2. A receiver to store the compressed air.
3. Air distribution lines to distribute the air to various components of the system.
4. Filter lubricator regulator (FLR) unit for conditioning of air and regulation of pressure.
5. Pneumatic control valves to regulate, control & monitor the air energy.
6. Pneumatic actuators.
7. Air driers.

## • Working of 5/3 valve:

The directional control valve must direct the flow from the compressor either to port A or port B. The fluid exhausted by the cylinder must be directed from the other port to back to tank. The valve shown has 5 ports and 3 positions so called as 5/3V.

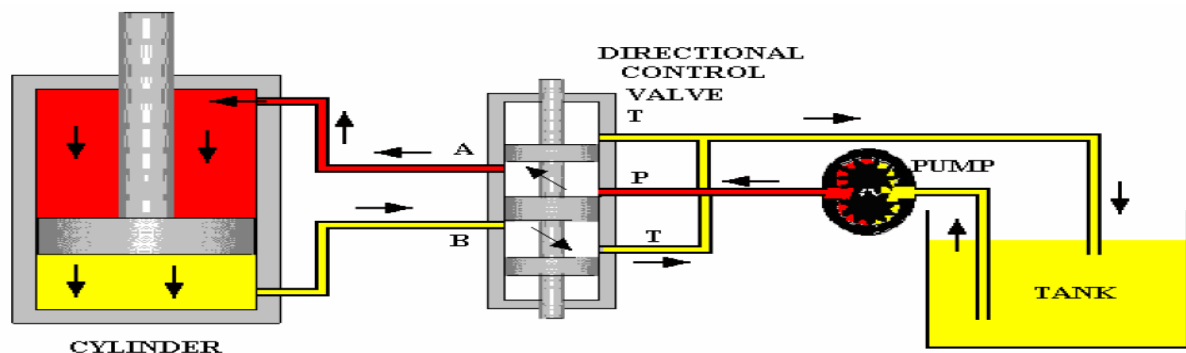

Valves are necessary to control the pressure, flow rate and direction of the fluid. Pneumatic systems are low pressure systems. Pneumatic valves are made from cheaper materials (e.g. aluminum and polymer) and are cheaper to manufacture. The directional control valve must direct the flow from the compressor either to port A or port B. The fluid being exhausted by the cylinder must be directed from the other port back to tank. The number of ports (External connections) and the number of positions describe such valves. The valve we used and shown above has 5 ports and 3 positions so it is designated as a 5/3 directional Control Valve. It is noted that the third position in a 5/3 valve is a center position. The air control mechanism inside 5/3 valve (usually a spool of some sort) is shifted into the center position inside the valve by one of two internal spring valve actuators. There is a spring located inside the valve at each end of the internal spool. When no external valve actuator is being exerted on the valve these springs center the spool into the valve's third position.

## X. TRANSMISSION SYSTEM

The mechanical power produced by prime over I used to drive various machines in the workshop and factories. A transmission system is the mechanism. The rotary motion of the motor is transmitted to the operative element to provide an operative working or auxiliary motion. When the required motion is rotary; the transmission takes place through mechanisms that transfer Rotary motion from one shaft to another. Transmission of the motion from the external source to the operative element can take place through Mechanical elements such as belts, Gears, chains etc.

Mechanical Transmission and its elements: -

- 1) Belt Transmission
- 2) Gear Transmission
- 3) Chain Transmission

### 1) Belt Transmission

Belt drive is one of the most common effective devices transmitting motion and power from one shaft to the other by means of thin inextensible belt over running over to pulleys. This largely used for general purpose on mills and factories especially when the distance between the Shafts is not very great.

When the center distance between the two shafts is large than the tight side of the belt should be the lower one the pulley called driver is mounted on the driving shaft while the shaft while the other, which is mounted on the shaft to which power is to be transmitted is called the driven pulley or follower.

When the belt moves over the pulleys there is always the possibility of slipping between the belt and pulley and hence the Character of the motion transmitted is not positive when positive action is required. Gears and chain must be used.

### 2) Gear Transmission

Efficiency of power transmission in belt and rope drives is less. The power may be transmitted from one shaft another by means of mating gears with high transmission Efficiency and a gear drive is also provide when the between driver and follower is very small.

### 3) Chain Transmission

Chains are used for high transmission number. They are mostly used when distance between center is short but the center distance is as much as 8m. They are now generally used for transmission of power in cycle, motor vehicle, and agriculture machinery in workshops.

It is general requirement for any machines that they should provision for regulating speed of travel

The regulation may be available in discrete steps or it may be steeples i.e. continuous. The format are known as stepped drives Ex. Lathe machine, milling machine, printing machine etc.

The pneumatic power is converted to straight line reciprocating motions by pneumatic cylinders. According to the operating principle, air cylinders can be sub-divided as (i) Single acting and (ii) Double acting cylinders.

1) **Single acting cylinder**:- In a single acting cylinder, the compressed air is fed only in one direction. Hence this cylinder can produce work in only one direction. The return movement of the piston is effected by a built-in spring or by application of an external force.

2) **Double acting cylinder** :-



Here we have used double acting cylinder. It is the pneumatic actuator, which is actuated using compressed air.

The Force exerted by the compressed air moves the piston in two directions in a double acting cylinder. In principle, the stroke length is unlimited, although buckling and bending must be considered before we select a particular size of piston diameter, rod length and stroke length. The double acting cylinder consists of 1) Cylinder tube, 2) Piston unit, 3) Double cup packing on piston, rod packing of 'O'rings, 4) Bronze rod guide, Piston rod, 6) End covers (flanges) 7) Port connection, 8) Cushion assembly. The cylinder is manufactured from aluminium solid bar with central bore on lathe machine. It is then made smooth internally using method of honing and lapping. It contains piston and piston rod, which reciprocates and fro with the application of high pressure air. The piston is fitted with the piston ring which is made of Teflon rubber to make perfect compression of the air. The material used for various parts differs for different types of cylinders depending upon applications.

### 3) 5/2 Direction control foot operated valve:

Its basic symbol is as shown the control of the to and fro motion of a pneumatic cylinder, the air energy has to be regulated, controlled, and reversed with a predetermined sequence in a pneumatic system. Similarly one has to control the quantity of pressure and flow rate to generate desired level of force and speed of actuation. To achieve these functions, valves are used to-

- (i) Start and stop pneumatic energy,
- (ii) Control the direction of flow of compressed air,
- (iii) Control the flow rate of the compressed air and
- (iv) Control the pressure rating of the compressed air. A direction control valve has two or three working positions generally. They are:

- 1) Neutral or zero position
- 2) Working position

The positions are mostly numbered as 0,1,2. Direction control valves are designated to indicate both the number of ways as well as the number of working positions such as 4/2, 3/2,5/2 means 5 ways / 2positions. Here we have used 5/2 direction control valve. In this design of direction control valve, 5 openings are provided. This ensures easy exhausting of the valve along with the two positions i.e. ON and OFF. Here the spool slides inside the main bore and according that the spool position is made ON or OFF due to the fact that the spool gets connected to the open side or the closed side of the air opening.

### 4) Air circulating devices:

The compressed air is stored in an air receiver from which air is drawn out in to the consumer point by means of pipe line. While laying out the pipe line for the system, one should take sufficient care and pay attention to see that the pressure drop from the generating point to the point of consumption remains as low as possible. For economical reason, it is always better if the total drop of pressure is kept limited to a maximum value of 0.1 bar or even less. The following factors are taken into account while selecting pneumatic pipeline and other air- line installations:-

- 1) Pressure of compressed air in the lines.
- 2) Total flow rate per unit time through the line.
- 3) Permissible pressure drop in the line.

4) Types of tube material and types of line fitting.

5) Length and diameter of tube or other pipelines.

6) Working environment.

Considered the above factors we have selected the flexible hose tubes of 1/8" diameter.

## XI. COMPONENTS OF PNEUMATIC SYSTEM

### • AIR CYLINDERS

Air cylinders are the means of converting our pressure in applied force and straight the motion. An air cylinder consist essentially of a tube sealed both ends by covers and fitted with a piston and piston rod. Compressed air admitted through a port at one end produces movement of the piston displaced air exhausted through a second port at other end.

The theoretical force of thrust available from a cylinder is directly proportional to the area as available pressure-

$$\text{FORCE} = 0.7854 * D^2 * P$$

Where,

D = cylinder bore,

P = applied pressure.

The majority of air cylinders are designed for working with maximum air pressure of the order of 10 bars, although the usual operating pressure is of the order of 3 bars. An air cylinder may be single acting capable of developing in one direction only, or double acting, acting capable of being pressurized from each and alternately developing an output force in both directions.

### • HAND LEVER VALVES

PIPE SIZE : 1/4", 3/8", AND 1/2" BSP

MEDIA : AIR

No. OF WAYS : 5 AND 3 WAY

ACTUATION : HANDLEVER

RETURN MECHANISM : SPRING PUSH-PULL

PRESSURE MACHINE : 0-10 Kg / CM<sup>2</sup>

SPOOL TYPE : 2 AND 3 POSITION WITH

**PIPING:** The function of the piping in either a hydraulic or a pneumatic system is to act as a leak proof carrier of the fluid.

**PIPE MATERIAL:** Steel pipes are normally used for air mains. For braid pipes or smaller lines up to about 25 mm. Bore copper piping nylon tubing is commonly employed with flexible lines at the take off points. Flexible nylon tubes may be used directly for smaller diameter hose or reinforced with braid for larger. Rubber hose is used for flexible lines where a wide working temperature is required or larger size is needed. A plain (unreinforced) polythene tubing is more flexible than nylon tubing. Typical maximum pressure rating 7 bar for 15 mm O.D. tubing is not for rigid installations except where adequate support by pipe clips can be arranged. Piping may be divided three classes: Rigid, Semi rigid, Flexible

# International Conference On Emerging Trends in Engineering and Management Research

NGSPM's Brahma Valley College of Engineering & Research Institute, Anjaneri, Nashik(MS)

(ICETEMR-16)

23rd March 2016, [www.conferenceworld.in](http://www.conferenceworld.in)

ISBN: 978-81-932074-7-5

**AIR LINES:** The efficiency of any pneumatic system fed through pipelines depends very largely on the pipe size adopted. Pipes, which are too small, will choke the flow, resulting in excessive pressure drop is directly proportional to length. Pressure drop figures, in fact are commonly quoted in terms of pressure drop per unit length. Pipe lengths, however is relatively insignificant as a design control parameter compared with pipe bore size, since pressure drop is inversely proportional to (bore)<sup>5</sup> approximately in other words, a small change in bore size can have a marked effect on pressure drop. Where as even doubling the pipe length will only result in doubling the pressure drop.

**Advantages** In the assemble process, significant productivity gains can be archive by utilizing energy source that is easy to able handle.

1. It has unique capability.
2. It die or punch is damaged we can easy change so it's maintenance cost is low.
3. It is multipurpose machine.
4. No electric contact to machine so it is safe for shock.
5. Easy to operate.
6. It is pollution free .
7. It is profitable.
8. Unit cost is very cheap .
9. Easy to assemble.
10. It is ideal for exercise.

## **Disadvantages.**

1. Pressure control device isn't control press at working because speed is not constant.
2. More space is required.
3. It is not self prime.
4. If any leakage efficiency is suddenly decreases.

**DESIGN:** In our attempt to design a pneumatic train we have adopted a very careful approach. Total design work has been divided into two parts mainly,

### 1. System Design

### 2) Mechanical Design

System design mainly concern with the various physical concerns and ergonomics, space requirements, arrangements of various components on the main frame of machine, number of controls, positions of this controls, ease of maintenance, scope of further improvements, height of machine components from the ground etc. In mechanical design, the components are categorized into two parts.

#### 1. Design Parts

#### 2. Parts to be purchased

For design parts, detailed design is done and dimensions thus obtained are compared to next highest dimensions which are readily available in the market. This simplifies the assembly as well as post production servicing work. The various tolerances on work pieces are specified in the manufacturing drawing. The process sheets are prepared and passed on to the manufacturing stage. The parts are to be purchased directly are specified and selected from standard catalogues.

# International Conference On Emerging Trends in Engineering and Management Research

NGSPM's Brahma Valley College of Engineering & Research Institute, Anjaneri, Nashik(MS)

(ICETEMR-16)

23rd March 2016, [www.conferenceworld.in](http://www.conferenceworld.in)

ISBN: 978-81-932074-7-5

**CHAIN:** A chain device consists of an endless chain wrapped around two Sprockets. The C plates Chain consists of a number of links connected by pin joints while the Sprockets are toothed wheels with a special profile for the teeth. The chain drives intermediate between belt and gear device. All automobile especially two wheelers the chain drive is used for transmission power generated by the engine to rear wheel is used for following reasons.

1. The efficiency of chain drive is high at times as high as 98%
2. A chain drive dose not slip
3. Although they generate noise, they present no fire Hazards and are unaffected by high temperature or atmospheric condition.
4. Chain drive is more compact then Belt or Gear Drive.

The chain drives requires proper maintenance particularly lubrication and slack adjustment. However chain can be easily replaced. Roller chain drives is used in two wheeler for transmission of power. There are five parts of roller chain.

1. Pin
2. Bushing
3. Roller
4. Inner plates
5. Outer plate

## XII. CONSTRUCTION OF CHAIN

The pin is press fitted to two outer link plates while the bush is press to inner link plates. The bush and the pin form a swivel joint and the outer link are freely fitted on bushes and during engagement, turn with the teeth of the sprocket wheels. This result is rolling friction instead of sliding friction between the roller and sprocket teeth and reduces wear. The pins bushes and rollers are made of alloy Steel.

**Table No. 1**

<b>ISO chain</b>	<b>Pitch P</b>	<b>Roller diameter D1</b>	<b>Width B1</b>	<b>Breaking load for Single stand chain</b>
08 B	12.70	8.51	7.75	18.2

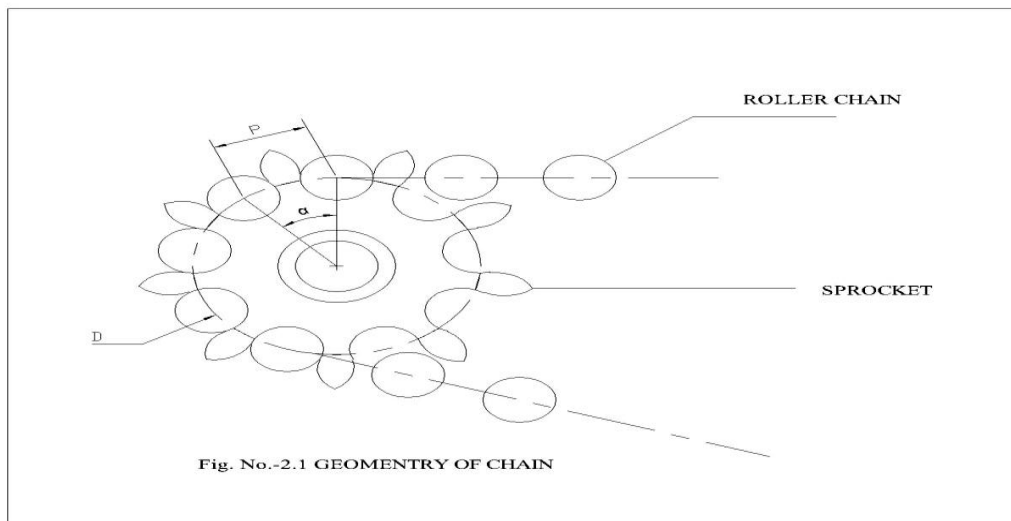

### XIII. INPUT DATA

TOTAL WEIGHT = 100 KG

NO OF LINKS = 4

2 LINKS OF 900 MM

1 LINK OF 600 MM

FORCE = 100 KG

$$= 100 \times 9.81$$

$$= 981 \text{ N}$$

$$\approx 1000 \text{ N}$$

NO OF LINKS = 4

HENCE,

$$\text{FORCE ON EACH LINK} = 1000 / 4$$

$$= 250 \text{ N}$$

CONSIDERING THE MAX VALUE OF FOS = 2

$$\text{BUCKLING LOAD ON EACH LINK} = 250 \times 2$$

$$= 500 \text{ N}$$

LET,

T1 = THICKNESS OF LINK

B1 = WIDTH OF LINK

$$\text{AREA OF LINK} = T1 \times B1$$

ASSUMING WIDTH OF THE LINK = 3 x T1

HENCE,

$$B1 = 3 \times T1$$

$$\text{AREA} = 3T1^2$$

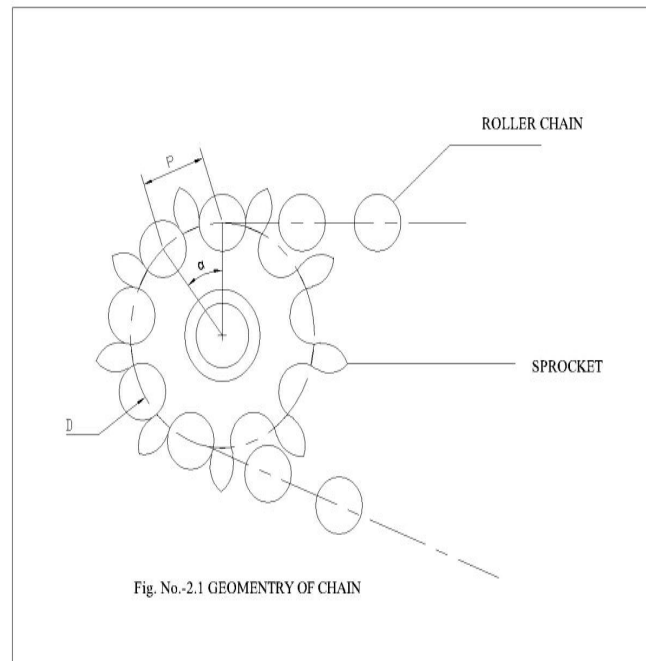

MI OF LINK

$$I = 1/12 \times T1.B1$$
$$= 2.25 T1^4$$

LET,

K = RADIUS OF GYRATION

A = AREA

$$K = \sqrt{I / A}$$

$$K = 0.75 T1$$

LINK - 1

$$L1 = 300 \text{ MM}$$

$$PR = 500 \text{ N}$$

$$\text{RANKINE CONSTANT} = a = 1 / 7500$$

$$\text{CRUSHING LOAD (FY)} = 325 \text{ MPa FOR MS}$$

NOW, BUCKLING LOAD

$$PR = FY \cdot A / 1 + a \lambda$$

$$\text{WHERE } \lambda = L / K$$

$$PR = F \cdot A / 1 + a (L / K)$$

$$975T1^4 - 500 T1 - 7980 = 0$$

$$T1 = 1.768 \text{ MM}$$

$$\approx 2 \text{ MM}$$

SIMILARLY

CALCULATING THE THICKNESS FOR LINK 2 AND 3

$$T2 = 2.44 \text{ MM}$$

$$T3 = 2.97 \text{ MM}$$

# International Conference On Emerging Trends in Engineering and Management Research

NGSPM's Brahma Valley College of Engineering & Research Institute, Anjaneri, Nashik(MS)

(ICETEMR-16)

23rd March 2016, [www.conferenceworld.in](http://www.conferenceworld.in)

ISBN: 978-81-932074-7-5

HENCE WE TAKE THICKNESS,  $T = 3 \text{ MM}$

Where,

$P = \text{pitch}$

$D = \text{pitch circle diameter of sprocket}$

$\alpha = \text{the pitch angel}$

$\alpha = 360/Z$  i.e.  $360/13 = 27.7$

$Z = \text{number of teeth on sprocket.}$

$$\sin \alpha / 2 = \frac{P/2}{D/2}$$

The velocity ratio of chain is given by

Where  $I = n_1/n_2 = Z_1 / Z_2$

$n_1, n_2 = \text{Speeds of driving and driven shafts (R.P.M.)}$

$Z_1, Z_2 = \text{Number of teeth on driving and driven shaft the average velocity of the chain is given by}$

$$V = \pi \times D \times n / 60 \times 10^3$$

$$V = Z \times p \times n / 60 \times 10^3$$

$V = \text{average velocity in meter/sec.}$

The length of chain is always expressed in terms of numbers of clanks.

$$L = L_n \times P$$

Where

$L = \text{length of chain in mm}$

$L_n = \text{number of link in the chain}$

The numbers of links in the chain are determined by the following relations

$$L_n = 2(a/p) + (Z_1 + Z_2 / 2) + (Z_n - Z_1 / 2 \times \pi) \times p/a$$

Where,

$a = \text{center distance between axis of driving and driven Sprocket.}$

$Z_1 = \text{Number of teeth on Smaller sprocket.}$

$Z_2 = \text{Number of teeth on larger Sprocket.}$

$$a = P/4 \{ [L_n - (Z_1 - Z_2 / 2)] + ([L_n - (Z_1 + Z_2 / 2)]^2 - 8 [Z_2 - Z_1 / 2 \times \pi]^2)^{1/2} \}$$

## Power retaining of roller Chain

The power transmitted by the roller chain can be expressed by the elementary equation

$$KW = P_1 \times V / 1000$$

$P_1 = \text{Allowable tension in chain}$

$V = \text{average velocity of chain}$

In automobile the chain is lubricated by oil and grease. But after some time the dust particle adhere on chain and goes in between roller and bushing and pins. Therefore it's necessary to clean the chain and re-lubricate it to improve its life. The wearing of chain also happens due to the following reasons.

### 4.1 Design of shaft

The shaft is subjected to fluctuating Loads, so shaft is under combined Bending and Torsion.

Therefore,

The equivalent Twisting Moment.

$$T_e = [(k_m \times M)^2 + (k_t \times T)^2]^{1/2}$$

The equivalent Bending Moment.

$$M_e = \frac{1}{2} [k_m \times M + \{(k_m \times M)^2 + (k_t \times T)^2\}^{1/2}]$$

Where,

$K_m$  = Combined Shock and Fatigue factor for bending.

$K_t$  = Combined Shock and Fatigue factor for torsion.

For Rotating Shaft

**Table No.4.1**

Nature of load	K <sub>m</sub>	K <sub>t</sub>
Gradually Applied Load	1.5	1.0
Suddenly applied load with minor shock	1.5 to 2.0	1.5 to 2.0
Suddenly applied load with Major Shock	2.0 to 3.0	1.5 to 3.0

#### XIV. SELECTION OF BEARING

As load acting on bearing consist of two components Radial & Thrust. So we have used single row deep groove bearing. This bearing has high load carrying capacity & suitable for high running speed.

**Table No. 4.6**

Principle Dimension			Basic load rating in N		Designation
d	D	B	C	Co	
10	26	10	9560	4500	6000

Where,

d = Inner diameter of bearing in mm

D = Outer diameter of bearing in mm

B = Axial width of bearing in mm

C = Dynamic load capacity in N

Co = Static load capacity in N

**Stroke :** - T.D.C. – B.D.C.

$$= 135-85$$

$$= \mathbf{50mm}$$

**Volume of air exhaust from piston and cylinder :-** Stroke X Area of Piston.



# International Conference On Emerging Trends in Engineering and Management Research

NGSPM's Brahma Valley College of Engineering & Research Institute, Anjaneri, Nashik(MS)

(ICETEMR-16)

23rd March 2016, www.conferenceworld.in

ISBN: 978-81-932074-7-5

$$= 50 \times 4 \times d^2 \times L$$

$$= 141370 \text{ mm}^3$$

**Volume of tank: -**

$$L = 250$$
$$D = 100$$
$$= \pi/4 \times 100^2 \times 250$$
$$= 1963.5 \times 10^3 \text{ mm}^3$$

**Time required filling the air tank :-** Volume of tank / Volume of Piston Exhaust

$$= 1963.5 \times 10^3 / 141370$$
$$= 14 \text{ Sec}$$

**Torque required to overcome friction :-**  $F \times r$

$$= 6 \times 10 / 2$$
$$T = 30 \text{ N- MM}$$

**Speed of the shaft :-** Tangential speed  $\times 60 / \text{Circumference}$

$$= 22.5 \times 60 / 3.14 \times 35$$
$$N = 12.28 \text{ rpm}$$

**Required Torque :-**  $2nNT/60$

$$= 2n \times 12.28 \times 30 / 60$$
$$W = 38.56 \text{ N-mm}$$

**Motor :-** should has greater than 38.56 watts.

$$1 \text{ HP} = 739 \text{ Watts.}$$

From this equation for 38.56 watts.

**0.008 HP motor is required**

**Speed: - 100 rpm,**

**Type: - Gear motor.**

**Pressure gauge = 4.2 Kg/cm<sup>2</sup>**

## PROCESS SHEETS

**PART NAME : WHEEL**  
**MATERIAL SIZE : 200mmx6mm.**  
**MATERIAL : Mild Steel.**  
**WEIGHT : 5 Kg.**  
**QUANTITY : 4.**

Sr. Number	OPERATION	MACHINE	TIME
1	Cutting the material 200 X 6 MM in sheet	Gas Cutting	30 Minute
2	Drill at the Center 8 mm in the Wheel	Drilling	20 Minute.

**PART NAME : ROLLING SHAFT.**

# International Conference On Emerging Trends in Engineering and Management Research

NGSPM's Brahma Valley College of Engineering & Research Institute, Anjaneri, Nashik(MS)

(ICETEMR-16)

23rd March 2016, [www.conferenceworld.in](http://www.conferenceworld.in)

ISBN: 978-81-932074-7-5

**MATERIAL SIZE** : 16mm X 320mm

**MATERIAL** : Mild Steel

**WEIGHT** : 1Kg.

**QUANTITY** : 2

Sr. Number	OPERATION	MACHINE	TIME
1)	Cutting the material 11mm X36mm	Power hack Saw	20 Minute
2)	Turning the material at both side 8mmX15mm	Lathe	30 Minute
3)	Turning the material At both side 9m X 10mm	Lathe	20 Minute
4)	Turning the material At both side 10mm X 65mm	Lathe	20 Minute

**PART NAME** : **AIR TANK CYLINDER**

**MATERIAL SIZE** : 100mm X 250mm

**MATERIAL** : Mild Steel

**WEIGHT** : 3Kg.

**QUANTITY** : 1

Sr. Number	OPERATION	MACHINE	TIME
1)	Cutting the material 170mm X 250mm	Power hackSaw	60 Minute
2)	Turning the Both side On lathe	Lathe	30 Minute
3)	Drill the Upper side Of 8mm	Drill	10 Minute

**PART NAME** : **BASE FRAME**

**MATERIAL SIZE** : 950mm X 300mm

**MATERIAL** : Cast iron

**WEIGHT** : 2Kg.

**QUANTITY** : 1

Sr. Number	OPERATION	MACHINE	TIME
1)	Cutting the material 950mm X 300mm	Power hackSaw	50 Minute
2)	Make Welding	Welding	120 Minute

# International Conference On Emerging Trends in Engineering and Management Research

NGSPM's Brahma Valley College of Engineering & Research Institute, Anjaneri, Nashik(MS)

(ICETEMR-16)

23rd March 2016, [www.conferenceworld.in](http://www.conferenceworld.in)

ISBN: 978-81-932074-7-5

## XV. ADVANTAGE & DIADVANTAGE

### ADVANTAGES

- 1) Air is available free of cost.
- 2) No. external supply is required.
- 3) Low Cost
- 4) No pollution & less Noisy system.
- 5) Efficiency is high.
- 6) No supervision is required.
- 7) High Portability.
- 8) No high leakage & reliable.
- 9) Easy construction & Very compact.
- 10) Low Maintenances.
- 11) It can be use with any Rotating systems.
- 12) Easily & immediately get results.
- 13) It can work for long time continuously.
- 14) Required less power to work the system.
- 15) A higher average of productive hours per day, because it Do not required frequent stop for fuel , and other servicing.

### XVI. DISADVANTAGE

- 1) Leakage problems;
- 2) Clogging may occurs.
- 3) System may affect by Thermal stresses.
- 4) Due to working burring of material occurs.

### XVII. APPLICATION

Compressed air is utilizing for opening & closing the Door- Windows of the train. It can be also used for AC system & refrigeration system by using pulse tube mechanism to store the food like fish, vegetable etc. Compressed air is used for Supporting Breaking system in emergency, by arranging many piston & cylinder in large capacity. It can also used to clean the train, cooling the radiator of engine. It is used for generation of electricity with the help of turbine mechanism to operate lighting, Horn, etc.

### XVIII. FURTHER MODIFICATION

- 1) We can drive more than one piston & cylinder on one shaft by using crank.
- 2) We can use screw compressor instead of piston & cylinder arrangement.
- 3) By using plus tube mechanism air can be use for Refrigeration & AC system.
- 4) By using Crankshaft on wheel shaft, we can compress the air instead of mounting Wheel.

# International Conference On Emerging Trends in Engineering and Management Research

NGSPM's Brahma Valley College of Engineering & Research Institute, Anjaneri, Nashik(MS)

(ICETEMR-16)

23rd March 2016, [www.conferenceworld.in](http://www.conferenceworld.in)

ISBN: 978-81-932074-7-5

5) More capacity tanks mounted to store large amount of air.

6) Safety valve can be used for safety of air tank.

## **XIX. CONCLUSION**

It has been a great experience while competing our project we come across lot many practical knowledge as well as experience. We had an opportunity to learn how project are been done. We received a lot of practical experience while working on this project as well as got enough freedom to our ideas for the improvement in our assigned project and check whether ideas are fruitful. While designing Train wheel operated compressor it was kept in mind that this machine is being manufactured only once. Therefore the design must be as perfect as possible and special attention is given during each manufacturing activity. We paid special attention during each & every manufacturing process that was carried out. In the manufacturing we come to know how theoretical aspects are implemented in actual practice, we got to learn about different manufacturing processes, welding, gear, cutting etc. We are really please to see our Train wheel operated composer for various system working successfully.

## **REFERENCE**

- [1]. **Machine Design** : - R.S.Khurmi, J.K. Gupta
- [2]. **Strength of Material** : - Prof. Sunil S. Deo
- [3]. **CATIA V5R11** :-- Prof. Sham Ticoo.
- [4]. **Ansys** : Prof. V. Sasov.
- [5]. **Engineering Manufacturing process** : - D. Malslov. & Danilevsky
- [6]. **Structural Mechanics.** : - P.S. Sawhney.
- [7]. **Precision Tools** : : - D.Saginaw