

# **TRAIN COLLISION AVOIDANCE AND REDUCTION OF SPEED USING RFID AND ZIGBEE**

**<sup>1</sup>Saraswathi.S, <sup>2</sup>Shruthi.A.N, <sup>3</sup>Roobini.R. <sup>4</sup>Prof. S.Deepa Rohini**

*<sup>1,2,3</sup>Dept. of EEE, <sup>4</sup>M.E-AP/EEE, Sri Sairam Engineering College, Chennai*

## **ABSTRACT**

*Rail network being the second largest in our nation, India and so train collision is one of the major concerns. More than 85 train accidents happened from 1980 to 2011 in India. In last two years itself more than 27 train accidents happened in India. To avoid this we need reliable train collision avoidance system which is economical. This paper presents the development of a system to avoid train collision and derailment by reduction of speed using RFID (Radio frequency identification) and ZIGBEE. Track monitoring mechanism uses microcontroller and provides the required features to the system.*

***Keywords: RFID, ZIGBEE, Microcontroller, Track Monitoring.***

## **I. INTRODUCTION**

The railways provide an eco friendly, economical and popular means of transportation in many parts of the world. Being the second largest in rail network, the main priority of our nation, India is to make it a safe and reliable mode of transportation. The past has witnessed a number of train accidents due to reasons such as human error, machine failures etc. Train collisions have created doubts about its reliability, causing loss of precious human life. Also the Indian Railways spends a huge amount over these disasters. All of these conclusively points towards the need for a reliable, stable and economical means of train collision avoidance system, also easy in its implementation. A number of anti collision devices have been developed over the years yet a stable system has not come into implementation.

The Anti Collision Device based on GPS and Microprocessor. GPS used to track the train current position but weather conditions might make information gathered to be incorrect. The ACD system is found to be ineffective because it does not considering any active inputs from existing Railway sign system. Geographical sensors have additionally been used that makes use of satellite for communication making the system complicated to implement.

In this proposed system we develop a train collision avoidance and speed reduction system using the RFID and ZIGBEE technologies integrated with the embedded system. RFID is used to sense the track information which is communicated among the trains by ZIGBEE technology. ZigBee technology was selected as a communication device because of its highly scalable, self-healing, low power and its unique radio properties. Also other features such as supporting large number of nodes, deployment is easy, very long battery life, secure, low cost and can be globally used and therefore one of the best wireless communications for embedded system. This

communicated information is then processed by the microcontroller and it gives instructions to take actions such as speed reduction, train stoppage.

## II. LITERATURE SURVEY

The existing conventional system rely on the oral communication through telephonic and telegraphic conversations as input for trains track allocation. This adds to the miscommunication of the information or communication gap as it involves human interference in the system and this may result in wrong allocation of the track for trains, leading to the train collision. The statistical research shows that in the developing countries 80% of worst collisions occurred due to either human error or incorrect decision making. IR sensors are used to identify the cracks in the rails but the geographic nature of the tracks adds to the limitations of the IR sensors. The Anti-collision device which does not consider any active inputs from existing Railway signaling system is ineffective, also lacks two way communications between the trains and the control centers or stations. Geographical sensors uses satellites for communication and hence costly and complicated to implement.

Implementing automatic system of track changing. RFID system senses the upcoming trains at a particular distance before the turnouts and actuates the track diverting systems [1]. Train collision accidents that takes place in platform, alert people about the train arrival. Uses microcontroller, ZigBee and LEDs [3]. RFID reader detects wrong Unique code automatically speed of the train is slow and stop. Uses Wi-Fi, RTSU act as a wireless base station and provide internet connection to trains [4]. A railway track switching system detects the train path to avoid the train collision using a microcontroller [5]. RFID tag is used to detect the station in which the train is present and this data is processed and send it to the display by using microcontroller. Automatic announcement has been implemented using voice Integrated Chip. RFID tag encoded with station name is fitted in the railway stations. Upon the arrival of the train in the station the microcontroller in the train receives the signal from RFID tag [6]. Automatic railway gate control using sensor and microcontroller. Sensor placed at certain distance from the gate provides the signal to the gate to close the gate automatically and an indicator light alerts the motorist about the train approaching [7].

## III. PROPOSED SYSTEM

In this proposed system we develop a train collision avoidance and speed reduction system using the RFID and ZIGBEE technologies integrated with the embedded system. RFID is used to sense the track information which is communicated among the trains by ZIGBEE technology. This communicated information is then processed by the microcontroller and it gives instructions to take actions such as speed reduction and train stoppage. Also this system has the feature to sense the fire and to alert the driver of the train with an alarm. This is done by using a temperature sensor circuit. Once a fire alert is given the power is shut down by the driver and water is sprinkled with the facility provided interiorly in the compartment.

## IV. BLOCK DIAGRAM DESCRIPTION

The block diagram consists of,

**Power supply:** Power supply is used to energize the equipment such as microcontroller, sensors, ZigBee module. It consists of amplifier, regulator, and rectifier. In our project 9V lead acid battery.

**RFID:** RFID Module convert radio waves returned from the RFID tag into a form that can be passed on to Controllers. RFID tags and readers have to be tuned to the same frequency in order to communicate; the most widely used is 125 kHz. An RFID system consists of two separate components: a tag and a reader. The tag contains an antenna connected to a small microchip containing up to two kilobytes of data. The reader or RFID scanner uses electromagnetic waves. To transmit these waves, the scanner uses an antenna. The tags antenna receives data from the scanner and transmits its particular chip information to the scanner. The data on the chip is usually stored in one of two types of memory, Read-Only Memory (ROM, most common) or Read/Write Memory. The RFID tag consists of a powered or no powered microchip and an antenna. It is a fast, affordable and automatic identification technology that uses radio frequency (RF) to transfer data between a RFID reader and a RFID tag.

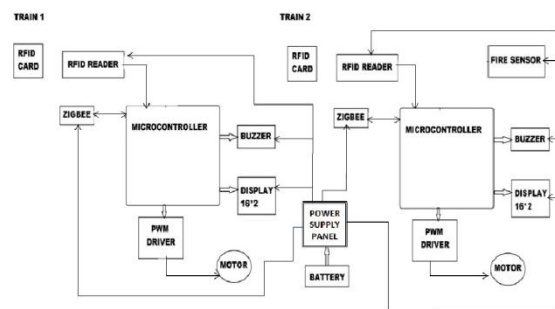

**Fig 1. Block diagram of the proposed system**

**ZigBee:** ZigBee is an established set of specifications for Wireless Personal Area Networking (WPAN), ZigBee is an IEEE 802.15.4 standard for data communications with business and consumer devices. ZigBee is targeted at radiofrequency (RF) applications which require a low data rate, long battery life, and secure networking. The low cost allows the technology to be widely deployed in wireless control and monitoring applications, the low power-usage allows longer life with smaller batteries, and the mesh networking provides high reliability. 802.15.4 defines the physical and MAC layers, and ZigBee defines the network and application layers.

**Microcontroller (PIC18F8722 Family):** The microcontroller used in the project is PIC18F6527. PIC is a family of modified Harvard architecture microcontrollers made by Microchip Technology. The PIC refers to "Peripheral Interface Controller". PIC are popular due to their low cost, large number of application, availability of low cost or free development tools, wide availability and serial programming capability.

Peripheral Highlights includes: (1) Two Master Synchronous Serial Port (MSSP) modules supporting 2/3/4-wire SPITM (all 4 modes) and I2CTM Master and Slave modes. (2) Two Capture/Compare/PWM (CCP) modules. (3) Three Enhanced Capture/Compare/PWM (ECCP) modules. (4) Two Enhanced Addressable USART modules. (5) 10-bit, up to 16-channel Analog-to-Digital. (6) Dual analog comparators with input multiplexing. (7) High-current sink/source 25mA/25mA. (8) Four programmable external interrupts and four input change interrupts. Special Microcontroller Features: (1) C compiler optimized architecture. (2) Power-saving Sleep

mode. (3) Data SRAM: 368 bytes and Data EEPROM: 256 bytes (4) Flash/Data EEPROM Retention: 100 years typical. (5) Under software control it's self-programmable. (6) Priority for interrupts. (7) 8 x 8 Single-Cycle Hardware Multiplier. (8) Extended Watchdog Timer (WDT):- Programmable period from 4 ms to 131s. (9) Fail-Safe Clock Monitor. (10) Two-Speed Oscillator Start-up and NanoWatt Technology. (11) Operating speed: 20 MHz, 200 ns instruction cycle, (12) Programmable code protection, (13) Operating voltage: 4.0-5.5V and Industrial temperature range (-40° to +85°C).

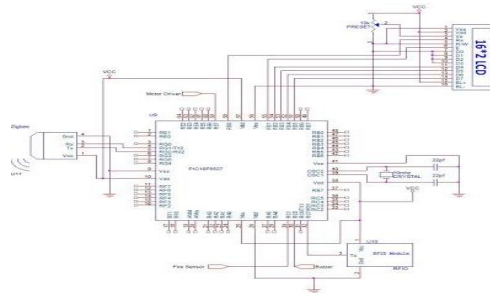

**Fig 2. Pin diagram of PIC18F6527**

*Display:* A 16x2 LCD display is used. These modules are preferred over seven segments the reasons being: LCDs are economical; easily programmable; have no imitation of displaying special & even custom characters (unlike in seven segments), animations and so on. A 16x2 LCD can display 16 characters per line and there are 2 such lines. Each character is displayed in 5x7 pixel matrix. This LCD has two registers, Command (stores the command instructions given to the LCD) and Data (stores the data to be displayed on the LCD). ASCII value of the character to be displayed on the LCD is the data.

*PWM driver:* It is used to provide the speed regulation mechanism in the system.

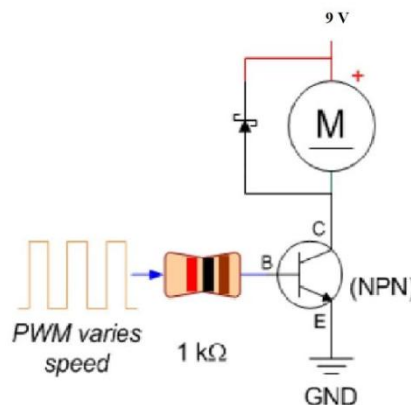

**Fig 3. Driver circuit**

*Buzzer and Temperature sensors:* Buzzer circuit is implemented to provide the necessary alarm which is needed in cases of fire accidents. The temperature sensors are used to sense the fire and provide the needed alter.

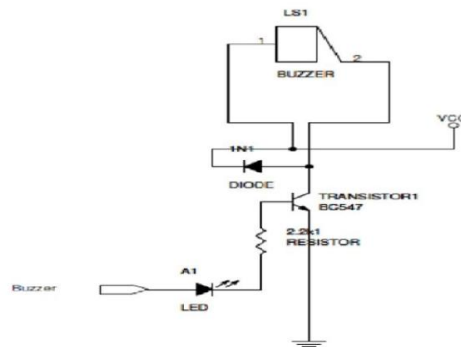

Fig 4. Buzzer circuit

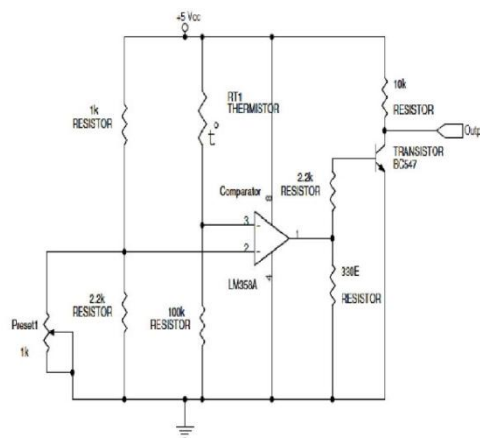

Fig 5. Circuit diagram for temperature sensor

## V. WORKING METHODOLOGY

The proposed system uses RFID, ZIGBEE network and microcontroller along with display to provide the collision avoidance and speed reduction mechanism. The train position is monitored using the RFID technology.

The use of RFID system is very efficient and important factor is their cheap availability. Also they require minimum infrastructure maintenance and this helps an easy development of the infrastructure. The RFID system provides a safe and a secure system. The RFID reader senses the RFID cards and receives data such train number, speed and direction in which the train is travelling. When the train approaches a bend, just before a few meters the train will be sensed on the basis of the unique code which is predefined in RF tag fixed to the train. When train crosses the RF transceiver system located near the track before the bend, the radio frequency wave that is transmitted continuously polarizes the tag and receives a response wave that has the information about the bend. This information is fed up to the microcontroller interfacing system and monitored by the software, which takes a prompt decision and controls the speed of the train. This system also prevents the collisions between the trains. The track and train detail sensed by the RFID reader is given to the microcontroller which transmits the information through ZIGBEE resulting in the communication among the trains in the vicinity. ZigBee coordinator which will form ZigBee networks will be present in each railway control station. Each train will have ZigBee routers which would join the ZigBee networks. Routers are used to extend the network. Thus a

mesh network is called a self-healing network where the different devices perform the routing in the network and if one node fails another node can be used for delivery. The microcontroller compares the data from the RFID reader and the ZIGBEE transmission to check if any two trains are in the same track. In case where two trains in close vicinity are in the same track the microcontroller gives the input to the driver system which results in stopping the train and thereby preventing any collision.

## VI. COMPARISON TABLE

**Table-1 Comparison**

S.No	Parameter	Existing system	Proposed system
1.	Features	GPS, GSM	RFID, ZigBee
2.	Location	Approximate location showing a circle signifying the moving train	Accurate location with latitude and longitude
3.	Weather conditions	Does not work in bad weather conditions	Works effectively in all weather conditions
4.	Implementation	Modifications are required to implement it with our Railway system	Easy implementation with the present Railway system.
5.	Cost	High cost	Compared to every other proposed systems this is the cheapest.

## VII. CONCLUSION

The implementation of this project provides a stable mechanism to avoid train accidents such as collision, derailment etc by regulating the speed of the trains. This system is useful in all weather conditions. The proposed system uses RFID and ZIGBEE technology integrated with the embedded system and therefore provides a reliable and also most economical system for avoiding the train accidents. Saving human life, protection against accidents and the communicable electronic systems are the added advantage.

## REFERENCES

- [1]. P.Santhini, B.Sahaya Jenila, D.Srimathi, M.Malarvizhi, S.Ashvini, "Smart Rail Track Director Based on PIC Microcontroller" International Journal of Innovative Research in Computer and Communication Engineering, Vol. 2, Issue 9, September 2014.

# International Conference On Emerging Trends in Engineering and Management Research

NGSPM's Brahma Valley College of Engineering & Research Institute, Anjaneri, Nashik(MS)

(ICETEMR-16)

23rd March 2016, [www.conferenceworld.in](http://www.conferenceworld.in)

ISBN: 978-81-932074-7-5

- [2]. Sahil Dange, "Design and implementation of anti collision railways system using hybrid of ZIGBEE network and internet of things" International Journal of Science, Technology & Management, Vol.04, Special Issue No. 01, March 2015.
- [3]. Brinda R, Ranjitha R, Sindhu J, Chaitra V, Chaithanya.S,"Design and Development of Intelligent Automatic Train Collision Avoidance System", ISSN (Online): 2347-2820, Volume -3, Issue-9 2015.
- [4]. T. Kantharaju, B.L. Mamatha," Collision Avoidance And Data Broadcasting For Railways Using RFID and RTSU's (CADBRRR)", IJREAT International Journal of Research in Engineering & Advanced Technology, Volume 3, Issue 2, April-May, 2015.
- [5]. Md. Reya Shad Azim, Khizir Mahmudi and C.K.Das., "Automatic Train Track Switching System with Computerized Control from the Central Monitoring Unit" International Journal of u- and e- Service, Science and Technology Vol.7, No.1, pp.201-212, 2014.
- [6]. Xiaoqiang Zhang and Manos Tentzeris, " Applications of Fast-Moving RFID Tagsin High-speed Railway Systems"International Journal of Engineering Business Management, Vol. 3, No. 1, pp. 27- 31,2011.
- [7]. Krishna, Shashi Yadav and Nidhi, "Automatic Railway Gate Control Using Microcontroller"ISSN: 0974-6471, Vol. 6, No. (4), December 2013.
- [8]. Kalpana Sharma, Jagdish Kumawat, Saurabh Maheshwari and Neeti Jain, " Railway Security System based on Wireless Sensor Networks: State of the Art"International Journal of Computer Applications (0975 – 8887) Volume 96– No.25, June 2014.