

METAL HYDRIDE BASED COOLING SYSTEMS

Gagan Varma¹ Ramrao Thakare² Prashant Thakare³

M.A.Pawar⁴

^{1,2,3} B.E. Mechanical Scholar BVCOE&RI

⁴ Assistant Professor Mechanical Dept. BVCOE&RI, Nashik (India)

ABSTRACT

To accelerate the rate at which hydrogen gas can be charged into a hydride based hydrogen storage tank and provide cooling to the system. Due to the charging process as the absorption reaction of hydrogen gas become a metal hydride bed which is exothermic. Due to this heat is removed from the system since the temperature is increased and reduces the absorption. Hence, the rate of hydrogen storage into a tank containing metal hydride materials strongly depends on the heat removal rate from the hydrogen storage system. The possibility to utilize low temperature heat (waste heat) to drive these systems has great potential, helping to reduce pollution if implemented. To increase the heat removal rate the following four approaches were explored:

- (i) Enhancement of the thermal conductivity of the metal hydride bed by incorporating conductivity-enhancing materials such as aluminum (Al) foam.
- (ii) The use of genetic algorithms to optimize the parameters and placement of spiral coil heat exchangers with fins.
- (iii) Introduction of an active cooling environment by embedding a helical coil heat exchanger into the hydrogen storage tank.
- (iv) Use of a physical mixing method to improve the heat removal rate.

Major applications are seen in air conditioning and heat supply for buildings and in air conditioning of automobiles. Although this technology offers the possibility to increase the energy efficiency of a car (by utilizing waste heat) and consequently reduces the CO₂ emissions, its weight specific cooling power has so far been the main obstacle for an automotive application

Keywords: *Air-Conditioning, Metal Hydride, PCT, Sorption, Thermal Cooling*

I. INTRODUCTION

While the hydrogen absorption-desorption characteristics are used for hydrogen storage, compression and purification, the reaction enthalpy changes may be applied in thermal energy storage and heat pumps. The simple metal hydride single-stage heat pump shown in Fig.1.1 consists of two reactors filled with different materials A and B between which hydrogen is cyclically exchanged. The machine is operated at three temperature levels ($T_D > T_M > T_C$) and two pressure levels ($P_H > P_L$). It is driven by heat input to A at the high temperature T_D , thereby desorbing hydrogen. Hydrogen flows to metal B which absorbs it forming a hydride and releasing the absorption enthalpy at a medium temperature level T_M (first half cycle). In the second half cycle, there is heat input to hydride B at a low temperature T_C , which is the cooling load. This heat is upgraded to a higher temperature level T_M

by desorption at B. Then hydrogen flows to A, where it is absorbed releasing absorption enthalpy at T_M . Between the two half cycles there are transition periods, where the two reactors have to be sensibly cooled or heated. The sensible heating causes thermal losses which can be compensated by internal heat and mass recovery between respective reactors. In the case of heat pump in Fig.1 there is a quasi-continuous heat output due to the cyclic operation of the machine. In case of a refrigerator ($T_C < T_A$, $T_M \approx T_A$) there is only one cold generating half cycle. The same holds for the thermodynamically reversed heat pump, the heat transformer; in which there is heat input at medium temperature in each half cycle, but heat output at high temperature only in one half cycle. In the latter two cases quasi-continuous cold/heat output can be achieved by operating two pairs of reactors in parallel with a phase shift of a half cycle.

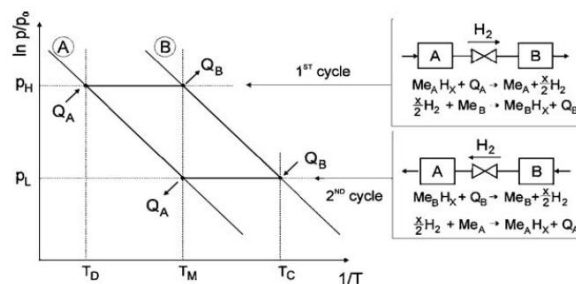

Figure 1.1 Operating principle of a single stage metal hydride heat pump

Also there were two main drawbacks with the existing system:

- 1) The mobile air conditioning system is not completely leak tight and the refrigerant emissions cause pollution and global warming on a large scale.
- 2) The compression of refrigerant vapour demands mechanical energy from the engine and consequently increases the overall fuel consumption along with the corresponding CO₂ emissions of the vehicle.

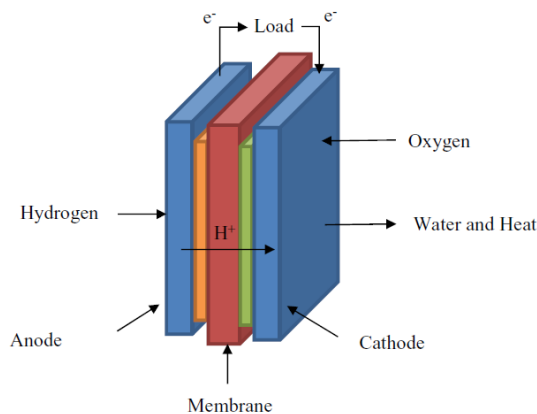

Figure 1.2 The operating principle of a fuel cell.



Fig.1.2 Metal hydride tank

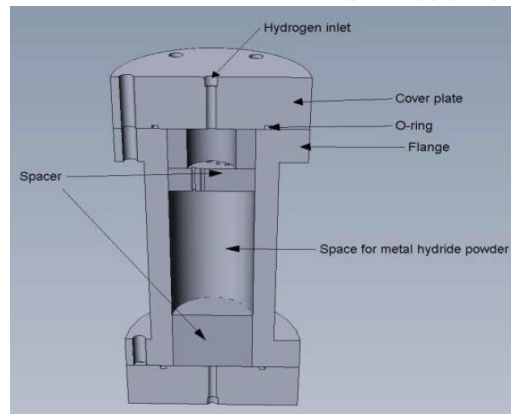

Fig.1.3 Sectional View Metal hydride tank

1.1 Objective

The objective is to accelerate the rate at which hydrogen gas can be charged into a hydride based hydrogen storage tank and provide cooling to the system.

II. THEORY

2.1 Metal Hydrides

Metal hydrides are metals which have been bonded to hydrogen to form a new compound. Generally the bond is covalent in nature, but some hydrides are formed from ionic bonds. It is the combination of a metal lattice with a hydrogen molecule. Many kinds of metals or alloys can react reversibly with a large amount of hydrogen under certain conditions. The products of the forward reaction are called metal hydrides (MH), and the reaction can be written as;

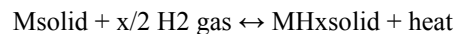

The chemical reaction of hydrogen and metal powder to form a metal hydride is given by the overall equation where M denotes any kind of metal or alloy able to absorb hydrogen (H₂), MH_x the corresponding metal hydride and ΔH the enthalpy of the reaction. It can be regarded as a reversible process and according to the principle of Le Chatelier-Braun, a pressure increase shifts the equilibrium to the right (hydrogen is absorbed), whereas a temperature increase shifts it to the left. A release of hydrogen (desorption) from the metal hydride is therefore possible by either reducing the hydrogen pressure or increasing the temperature. As the hydrogen absorption is generally exothermic, the endothermic desorption tends to cool the metal powder. The MH materials have widely attracted attention since the successful development of some members with great potential for hydrogen storage, such as LaNi₅, TiFe and Mg₂Ni. Moreover, after years of study, the applications of MH have been much extended. e.g. separation/purification of gas mixtures with hydrogen isotopes, heat pumping from low to high temperature, periodical heat storage and the thermal compression of hydrogen. Generally the MH related applications share the common advantages of being environmentally benign, compact and flexible for various operating conditions. Metal hydrides (MH) possess several superiorities to other hydrogen storage media in several aspects such as safety and compact storage. Metal hydrides display very high volumetric storage densities, typically 100 to 120 grams of hydrogen per liter. A lot of heat is released during hydrogen absorption process, whereas much heat is absorbed during hydrogen desorption process. A continuous cycle of adsorption and desorption is used to provide

the required cooling. The stability (dissociation pressure) of the metal hydride phase is one important issue for its applicability. Technically relevant pressure and temperature conditions of the metal-hydrogen reaction depend on the desired application but can be typically assumed as $p \approx 1 - 100$ bar and $T \approx 240 - 750$ K, respectively.

2.2. Mechanism of H2 movement through the metal crystal lattice

The H2 molecule is first weakly physisorbed on the surface and the chemisorbed as strongly bound, individual H-atoms. The size of the hydrogen atoms is lighter and smaller than the metal atoms; therefore, they diffuse quickly from the surface into the periodic sites in the metal crystal lattice

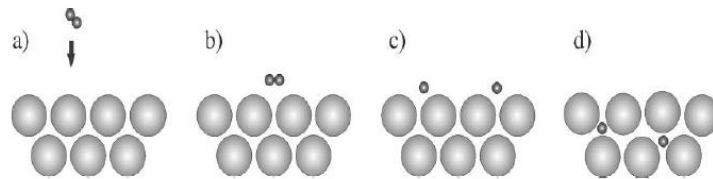

Figure 2.2.1 Movement of hydrogen molecules

2.3. Selection of Alloys

Performance of the MHHP systems are characterized by coefficient of performance (COP) and specific cooling power (SCP). These largely depend on the thermodynamic and thermophysical properties of the metal hydride pairs. They should be compact in design, i.e. low mass and/or low volume, have a long life and low performance degradation, and they should be economic. Therefore, metal hydrides used for MHHCS should respectively have suitable properties, e.g. high enthalpy of formation, low specific heat, and high hydrogen absorption capacity, fast reaction kinetics, favorable equilibrium pressures, low hysteresis, flat plateau, simple activation process, minimum degradation after cyclic operation, low cost, etc. There is a plethora of metal hydrides which are potentially suitable.

III.PREPARATION

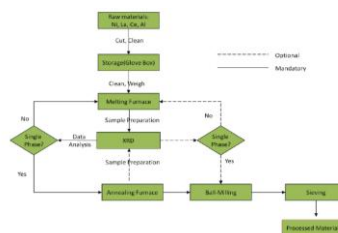

Figure 3.1 Preparation of Metal Hydride alloys

IV.WORKING

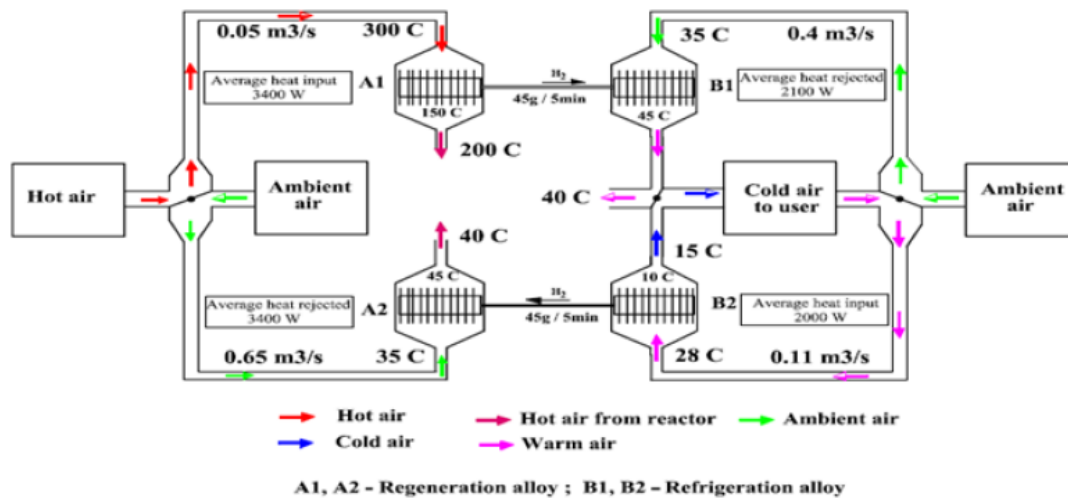

Figure 4.1. Process Flow Diagram Of First Half Cycle

- There are two types of reactors: HT(High temperature) and LT (Low temperature)
- The reactors are made to undergo a process known as activation which involves infusing hydrogen in the reactors.
- HT reactors absorb hydrogen at room temperatures and desorbs at high temperatures.
- LT reactors absorb at room temperatures and desorbs at low temperatures.
- Hot exhaust is passed to the HT reactor and the reactor desorbs hydrogen gas.
- The gas travels to the LT reactor and ambient air is passed.

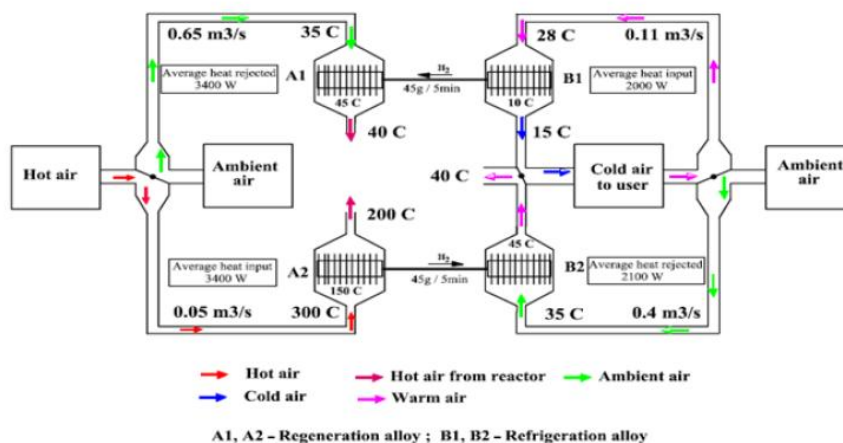

Figure 4.2. Process flow diagram of second half cycle

- The LT reactor absorbs the hydrogen in an exothermic reaction.
- This process continues until there is a concentration difference between the HT and LT reactor.
- In the next half cycle ambient air is passed to the LT reactor and the reactor desorbs hydrogen gas in an endothermic reaction.
- During this process the temperature of the air is reduced and is passed on to the user.
- The hydrogen travels back to the HT reactor which absorbs the hydrogen in the presence of ambient air.

- This process continues until there is a concentration difference between the HT and LT reactor.
- In the next half cycle the reactors are interchanged. These two cycles are repeated over and over to provide the necessary cooling

V. ADVANTAGES

- Improved fuel efficiency
- Proper utilization of a waste commodity and turning it into something useful.
- Traditional refrigerants can be avoided.
- Less pollution and hence reduced global warming.
- Decreases carbon footprint of vehicles.
- Hydrogen is a renewable source of energy; hence we don't have to worry about its depletion.

VI. CONCLUSION

Metal hydrides are working materials for thermally driven solid sorption cooling machines with hydrogen as working fluid. The systems can cover a wide range of operating temperatures from cryogenic applications to comfort air conditioning. A variety of heat sources from solar heat to automobile exhaust gases can be used to drive the cooling systems. In recent years various designs of such machines have been successfully demonstrated on a laboratory model or prototype scales. In fact, these can be most appropriate for small capacity portable or mobile cooling applications.

REFERENCES

- [1] P.Muthukumar,M.Groll; Erratum to "Metal hydride based heating and cooling systems: A review";International Journal of Hydrogen Energy 35 (2010) 3817-3831
- [2] Fusheng Yang, Zaoxiao Zhang;" Simulation Studies on the Coupling Process of Heat/Mass Transfer in a Metal Hydride Reactor"; Xi'an Jiaotong University,P.R.China M. Chandra Sekhar Reddy., Thermal Analysis of A Heat Sink For Electronics Cooling, International Journal of Mechanical Engineering and Technology, 6(11), 2015, pp. 145 - 153
- [3] Feng Win,Jiangping Chen,Manqi Lu,Zhiju Chen, Yimin Zhou,Ke Yang ;"Development of a metal hydride refrigeration system as an exhaust gas-driven automobile air conditioner";Renewable Energy 32 (2007)
- [4] J.Paya,M.Linder,E.Laurien,J.M.Corberan;"Dynamic model and experimental results of a thermally driven metal hydride cooling system";International Journal of Hydrogen Energy 34 (2009) 3173-3184
- [5] F.S. Yang,G.X.Wang,Z.X.Zhang,X.Y.Meng, V.Rudolph;" Design of the metal hydride reactors- A review on the key technical issues"; International Journal of Hydrogen Energy 35 (2010) 3832-3840
- [6] Marc Linder;"Automotive Cooling Systems based on Metal Hydrides"; Institute of Nuclear Technology and Energy Systems, University of Stuttgart,2010
- [7] Ch.Veeraju, M.Ram Gopal; " Heat and mass transfer studies on plate fin-and-elliptical tube metal hydride reactors"; Applied Thermal Engineering 30 (2010)