

COMPARISON OF DVR AND D-STATCOM FOR HARMONIC COMPENSATION BASED ON NON ITERATIVE OPTIMIZATION ALGORITHM

J. Arun Venkatesh¹, P. Swethamarai², I. Felice Browni³

^{1,2}Department of Electrical and Electronics Engineering, KCG College of Technology, Chennai, India

ABSTRACT

This paper proposes a novel method for elimination of harmonics based on Non-Iterative Optimized Algorithm. The main aim is to mitigate the harmonic content in the supply current, load current and load voltage. The main objective of the algorithm is to obtain the optimization by mitigating the harmonics in one step calculation. This algorithm uses the conductance factor to eliminate the harmonics in source and load. The conductance factors are obtained to maximize source power factors and thus mitigating harmonics in the system. The Total Harmonic Distortion (THD) limits for the source current and the total power and average power in the system is used as constraints to achieve maximum source power factor. The algorithm has been implemented for DSTATCOM and DVR and the results has been compared.

Keywords : *Distributed Static Synchronous Compensator (D-STATCOM), Dynamic Voltage Restorer, Non Iterative Optimization Algorithm, Power Quality, Total Harmonic Distortion (THD)*

I. INTRODUCTION

Power Quality is mainly a distribution side problem. The term power quality refers to maintaining a near sinusoidal voltage at the distribution side at rated frequency and magnitude. The main cause of the power quality problems are due to lightning, energisation of transformers and capacitors, sudden switching of heavy loads, failure of equipment and power electronic loads. Harmonics is a type of distortion. The harmonics may be in voltage or current. It is mainly caused due to power electronic converters and power electronic loads. The measure of voltage harmonics is known as THD and current harmonics is TDD. The Power Quality problem, harmonics can be compensated by using filters. The STATCOM used in the distribution system is known as D-STATCOM. The D-STATCOM has the property of high speed control of reactive power to provide voltage stabilization, flicker suppression. In the D-STATCOM the voltage source converter is designed by using GTO or IGBT. Protects the utility transmission or distribution system from voltage sags and/or flicker caused by rapidly varying reactive current demand. Provides leading or lagging reactive power to achieve system stability during transient conditions in utility. In industrial facilities to compensate for voltage sag and flicker caused by non-linear dynamic loads, enabling such problem loads to co-exist on the same feeder as more sensitive loads. Instantaneously exchanges reactive power with the distribution system without the use of bulky capacitors or reactors.

II. D-STATCOM AND DVR

The Power Quality problem, harmonics can be compensated by using filters. The STATCOM used in the distribution system is known as D-STATCOM. The D-STATCOM has the property of high speed control of reactive power to provide

voltage stabilization, flicker suppression. In the D-STATCOM the voltage source converter is designed by using GTO or IGBT. Protects the utility transmission or distribution system from voltage sags and/or flicker caused by rapidly varying reactive current demand. Provides leading or lagging reactive power to achieve system stability during transient conditions in utility. In industrial facilities to compensate for voltage sag and flicker caused by non-linear dynamic loads, enabling such problem loads to co-exist on the same feeder as more sensitive loads. Instantaneously exchanges reactive power with the distribution system without the use of bulky capacitors or reactors.

A static synchronous compensator (STATCOM), also known as a "static synchronous condenser" ("STATCON"), is a regulating device used on alternating current electricity transmission networks. It is based on a power electronics voltage-source converter and can act as either a source or sink of reactive AC power to an electricity network. If connected to a source of power it can also provide active AC power. It is a member of the FACTS family of devices. The system with D-STATCOM is represented in Fig. 1. as shown. The Power Quality problem, harmonics can be compensated by using filters. A Dynamic Voltage Restorer (DVR) is a series connected solid state device that injects voltage into the system in order to regulate the load side voltage. The basic structure of a DVR is shown in Fig.1. It is normally installed in a distribution system between the supply and critical load feeder. The equivalent circuit of DVR is represented in Fig. 2. as shown.

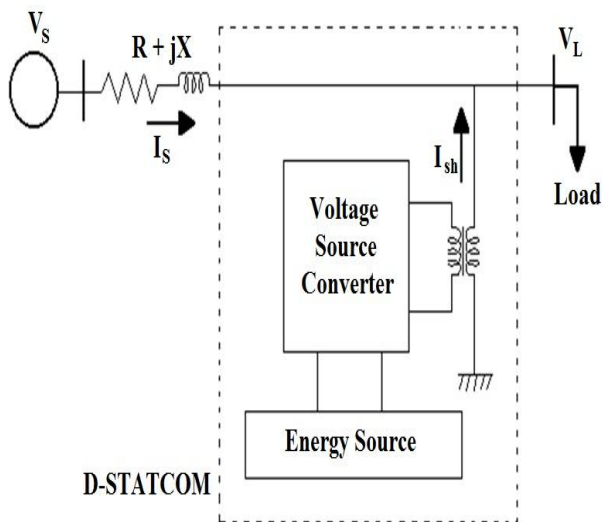

Fig. 1. System with D-STATCOM

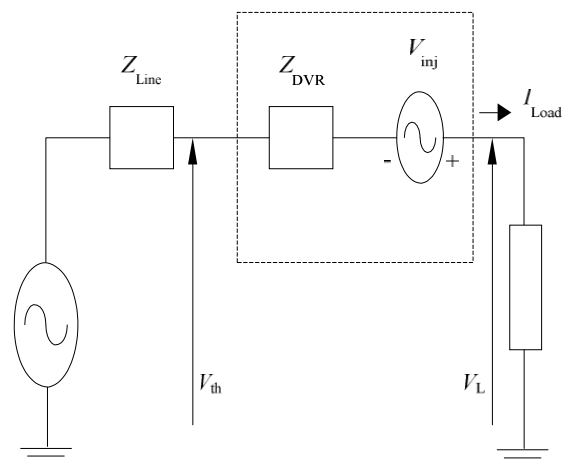

Fig. 2. Equivalent Circuit of DVR

III. NON ITERATIVE OPTIMIZATION ALGORITHM

The optimization algorithm is used to achieve optimality conditions based on equality and inequality constraints. The term optimization refers to the selection of a best element from some set of available alternatives. In the simplest case, an optimization problem consists of maximizing or minimizing a real function by systematically choosing input values from within an allowed set and computing the value of the function. The generalization of optimization theory and techniques to other formulations comprises a large area of applied mathematics. More generally, optimization includes finding "best available" values of some objective function given a defined domain, including a variety of different types of objective functions and different types of domains. The optimization problem is represented in terms of a function that is to be solved depending on the constraints. In

the solving of problem the feasibility has to be achieved to have the optimality achieved. There are many methods and algorithms to obtain optimization.

In this paper the optimization is achieved by using the calculus of optimization technique. The technique is Karush Kuhn Tucker (KKT) optimality conditions. The equations corresponding to the KKT conditions are represented as shown

- Objective Function : $f(x)$
 Subject to Constraints : (i) $g_i(x) \leq 0$
 (ii) $h_j(x) = 0$
 Constants used : (i) μ_i where $(i=1, \dots, m)$
 (ii) λ_j where $(j=1, \dots, l)$

By using the above equations two possibilities achieved for optimization as

- (i) Maximize $f(x) : \Delta f(x^*)$
- (ii) Minimize $f(x) : -\Delta f(x^*)$

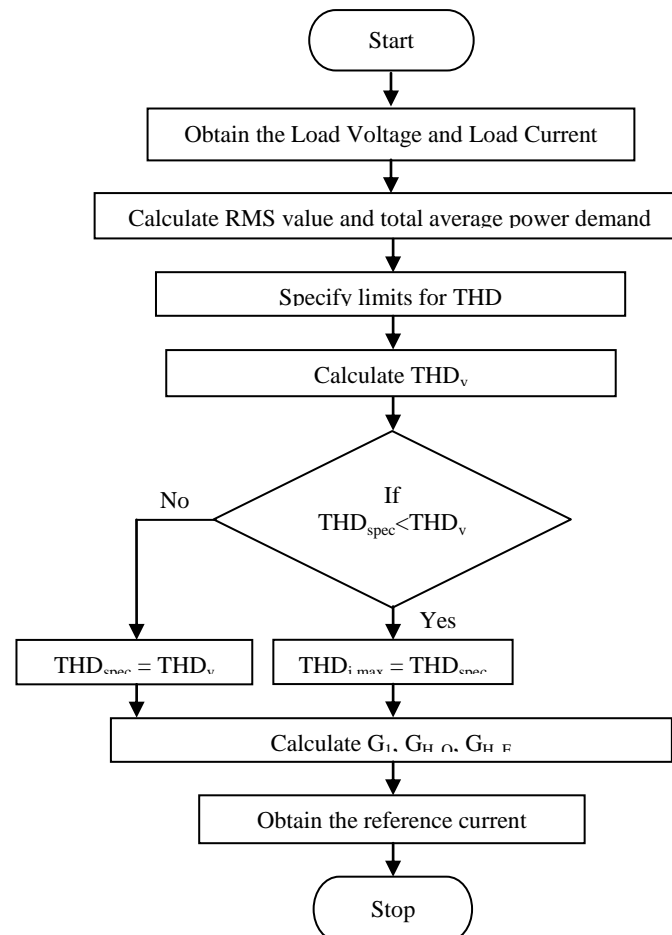

Fig. 3. Flowchart of Non-Iterative Optimization Algorithm for Harmonics

For the elimination of harmonics in the system voltage and current, three conductance factors is estimated using single step calculation from which the reference signal for the pulse generation is obtained. For the single step calculation we have the objective function to maximize the source power factor based on the equality constraint

of constant power flow at load and inequality constraint having the limits for the THD in current. The process of single step non iterative optimization algorithm is represented in flowchart as shown in Fig. 2. The objective is to maximize the source power factor, which can be achieved by minimizing the square of the apparent power calculated using the extracted balanced set of voltages and the desired source current of any phase.

$$\text{Objective Function: } f = \sum_{n=1}^h V'_{sn}{}^2 \sum_{n=1}^h G_n{}^2 V'_{sn}{}^2 \quad (1)$$

For the desired source currents to be balanced, the three source currents should supply the demanded average total power equally. Therefore, the equality constraint for any phase can be written as

$$\text{Equality Constraint: } \frac{P_{Lavg} + P_{Loss}}{3} - \sum_{n=1}^h G_n V'_{sn}{}^2 = 0 \quad (2)$$

As per IEEE Standard 519, the limit on the current distortion for individual even harmonics is 25% of the limit for odd harmonics. To address this, different THD limits for the current distortion due to odd and even harmonics are considered in this paper. The upper bounds on the source current harmonic distortion due to odd and even harmonics are denoted as THD_{i,max_o} and THD_{i,max_e} , respectively. The inequality constraints for odd and even harmonics is given by

$$THD_{i_o}{}^2 \leq THD_{i,max_o}{}^2 \quad (3) \quad THD_{i_e}{}^2 \leq THD_{i,max_e}{}^2 \quad (4)$$

In which the values of THD are obtained as

$$THDi_o = \frac{\sqrt{\sum_{o=3,5,\dots}^h G_o{}^2 V'_{so}{}^2}}{G_1 V'_{s1}} \quad (5) \quad THDi_e = \frac{\sqrt{\sum_{e=2,4,\dots}^h G_e{}^2 V'_{se}{}^2}}{G_1 V'_{s1}} \quad (6)$$

THD_{spec_o} and THD_{spec_e} pre specified THD limits on the source current harmonic distortion due to odd and even harmonics, respectively. For the cases where the source voltage THDs due to odd and even harmonics THD_{v_o} and THD_{v_e} are greater than THD_{spec_o} and THD_{spec_e} , respectively, the source current THDs should be equal to the prespecified THD values to achieve maximum power factor. On the other cases for THD_{v_o} and THD_{v_e} are less than THD_{spec_o} and THD_{spec_e} , respectively, the source current THDs should be equal to the supply voltage THDs to maximize the source-side power factor. This can be mathematically represented as shown in equations below

$$THDi,max_o = THD_{spec_o}, \text{ if } THD_{spec_o} < THD_{v_o} \quad THDi,max_e = THD_{spec_e}, \text{ if } THD_{spec_e} < THD_{v_e} \\ = THD_{v_o}, \text{ otherwise} \quad (7) \quad = THD_{v_e}, \text{ otherwise} \quad (8)$$

By using equations (7) and (8) the inequality limits can be obtained as equality constraints as represented in equation (9) and equation (10)

$$\sum_{o=3,5,\dots}^h G_o{}^2 V'_{so}{}^2 - THD_{i,max_o}{}^2 G_1{}^2 V'_{s1}{}^2 = 0 \quad (9) \quad \sum_{e=2,4,\dots}^h G_e{}^2 V'_{se}{}^2 - THD_{i,max_e}{}^2 G_1{}^2 V'_{s1}{}^2 = 0 \quad (10)$$

The Lagrangian function is used to obtain the optimality and is represented as

$$L = \sum_{n=1}^h V'_{sn}{}^2 \sum_{n=1}^h G_n{}^2 V'_{sn}{}^2 + \lambda_1 \left(\frac{P_{Lavg} + P_{Loss}}{3} - \sum_{n=1}^h G_n V'_{sn}{}^2 \right) + \lambda_2 \left(\sum_{o=3,5,\dots}^h G_o{}^2 V'_{so}{}^2 - THD_{i,max_o}{}^2 G_1{}^2 V'_{s1}{}^2 \right) + \lambda_3 \left(\sum_{e=2,4,\dots}^h G_e{}^2 V'_{se}{}^2 - THD_{i,max_e}{}^2 G_1{}^2 V'_{s1}{}^2 \right) \quad (11)$$

The Conductance factors that are obtained using the single step calculation is shown as

$$G_{H_o} = \frac{THD_{i,max_o}}{THD_{v_o}} G_1 \quad (12) \quad G_{H_e} = \frac{THD_{i,max_e}}{THD_{v_e}} G_1 \quad (13)$$

$$G_1 = \frac{P_{Lavg} + P_{Loss}}{3V'_{s1}{}^2 (1 + THD_{i,max_o} THD_{v_o} + THD_{i,max_e} THD_{v_e})} \quad (14)$$

The Reference Current generated by the control algorithm is represented as

$$i'_{sx}(t) = G_1 v'_{sx1} + G_{H_o} \sum_{o=3,5,\dots}^h v'_{sxo} + G_{H_e} \sum_{e=2,4,\dots}^h v'_{sxe}, \quad x = a, b, c \quad (15)$$

IV. SIMULATION AND RESULTS

In this paper, to verify the performance of the Non Iterative Optimized Algorithm operation the analysis of the system in mitigation of harmonics is done in three conditions. The simulation is done by using the MATLAB/SIMULINK environment. The simulation results are given as discussed. In this case the simulation for the system is done without use of D-STATCOM for mitigation of harmonics in the system. Thus there will be harmonics present in the system and this harmonics present in the system is analysed. The waveforms of source voltage, source current, load voltage and load current are given in Fig. 4(a), 4(b), 4(c) and 4(d). The Table I shows the FFT analysis about the harmonics content present in the system. The FFT analysis is done for source voltage, source current, load voltage and load current. The harmonic content is separately analysed for even and odd harmonics.

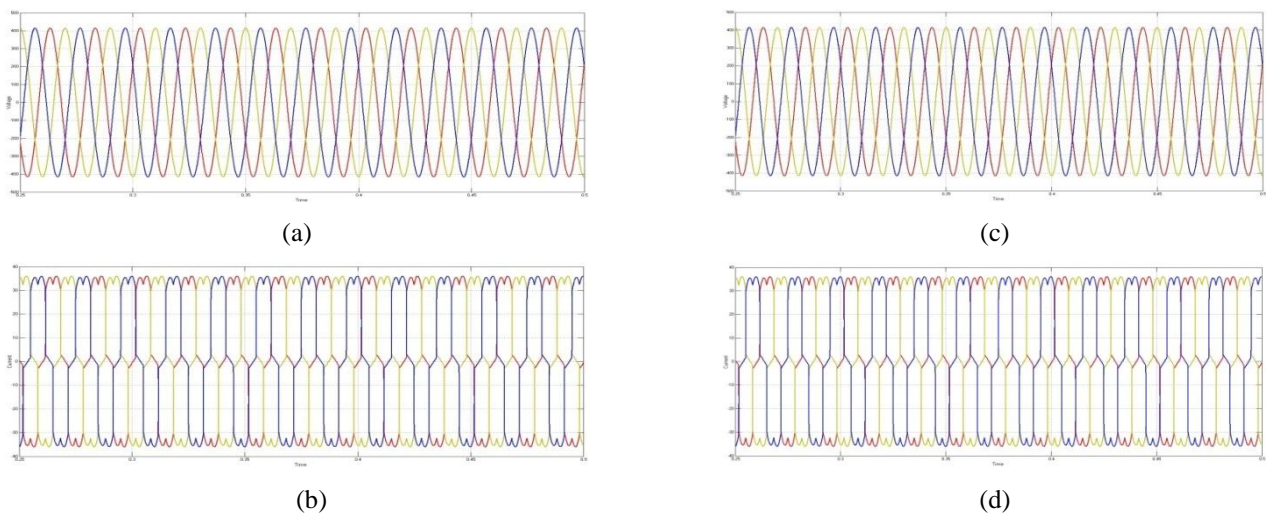

Fig. 4. Simulation results of System without using D-STATCOM. (a) Source Voltage. (b) Source Current. (c) Load Voltage. (d) Load Current.

In this case the simulation for the system is done with D-STATCOM for mitigation of harmonics in the system. The D-STATCOM is designed using the IGBT based inverter and the pulses for the IGBT switches are given by using the Non Iterative Optimization Algorithm based controller. In this case the D-STATCOM is operated using the controller, it is operated to mitigate the harmonics by using the feedback signal from the system. The waveforms of source voltage, source current, load voltage and load current are shown in Fig. 5(a), 5(b), 5(c) and 5(d). The Table II shows the FFT analysis about the harmonics content present in the system. The FFT analysis is done for source voltage, source current, load voltage and load current. The harmonic content is separately analysed for even and odd harmonics.

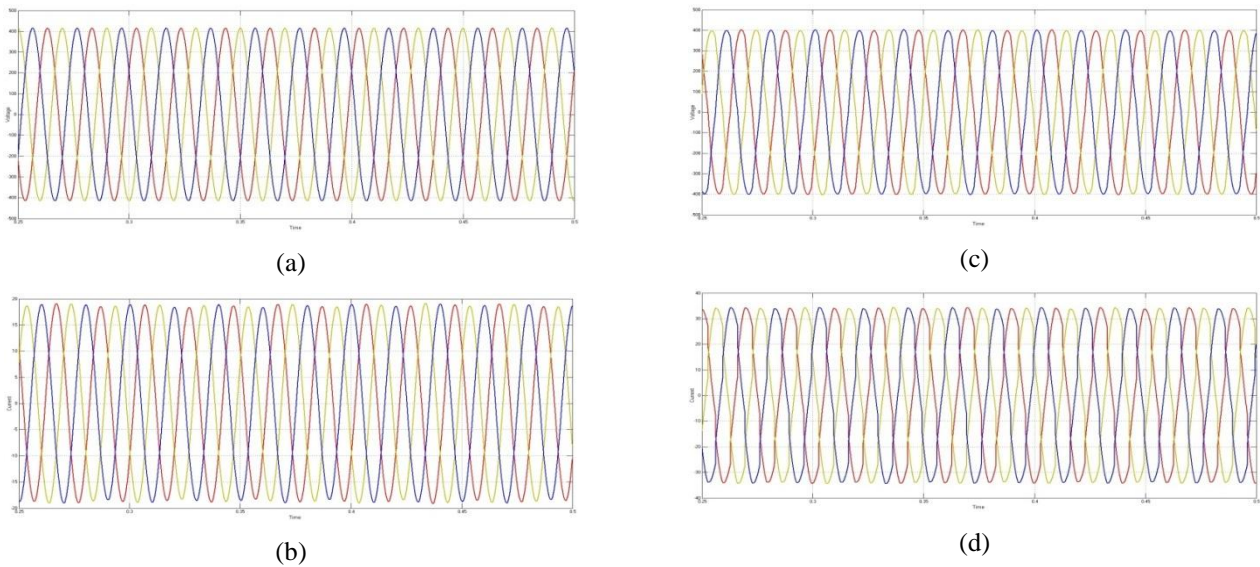

Fig. 5. Simulation results of System using D-STATCOM with controller. (a) Source Voltage. (b) Source Current. (c) Load Voltage. (d) Load Current.

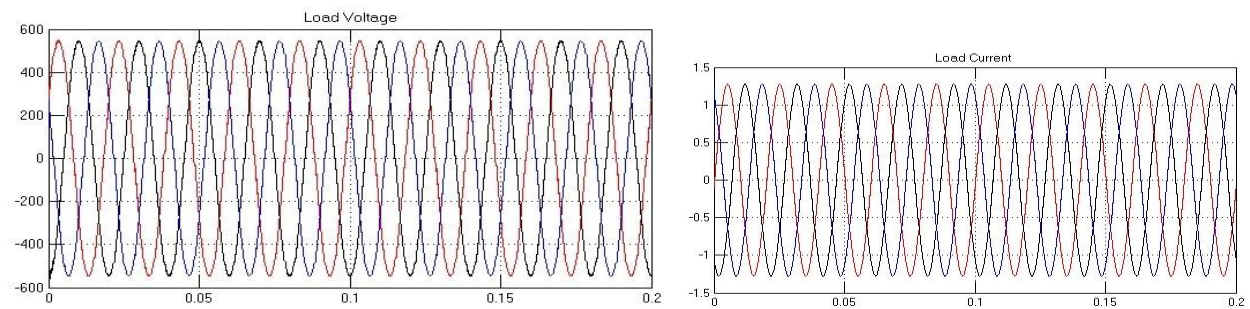

Fig. 6. Simulation results of System using DVR with controller. (a) Load Voltage. (b) Load Current.

The Total Harmonic Distortion (THD) in the system is represented in the Table I.

TABLE I. THD IN SYSTEM

	Total Harmonic Distortion	
	Before Compensation	After Compensation
Source Voltage	0.79 %	0.17 %
Source Current	26.57 %	0.56 %
Load Voltage	2.42 %	1.08 %
Load Current	26.57 %	4.59 %

TABLE II. THD IN SYSTEM

	Total Harmonic Distortion	
	Before Compensation	After Compensation
Load Voltage	21.95 %	3.16 %
Load Current	15.38 %	2.92 %

V. CONCLUSION

A single step non-iterative optimization algorithm is being developed for D-STATCOM and DVR for mitigation of harmonics in the system and this is being designed for three phase three wire system. The proposed algorithm uses the calculus technique of optimization and hence there is only single step calculation and so the time taken for computation is reduced from other optimization algorithm which takes many iterations to achieve optimization. The Comparison results are shown in the table.

REFERENCES

- [1] S. M.-R. Rafiei, H. A. Toliyat, R. Ghazi, and T. Gopalarathnam, "An optimal and flexible control strategy for active filtering and power factor correction under non-sinusoidal line voltages," *IEEE Trans. Power Del.*, vol. 16, no. 2, pp. 297–305, Apr. 2001.
- [2] G. W. Chang and C. M. Yeh, "Optimisation-based strategy for shunt active power filter control under non-ideal supply voltages," *Proc. Inst. Elect. Eng.—Elect. Power Appl.*, vol. 152, no. 2, pp. 182–190, Mar. 4, 2005.
- [3] G. W. Chang, C.-M. Yeh, and W.-C. Chen, "Meeting IEEE-519 current harmonics and power factor constraints with a three-phase three-wire active power filter under distorted source voltages," *IEEE Trans. Power Del.*, vol. 21, no. 3, pp. 1648–1654, Jul. 2006.
- [4] G. W. Chang, "A new approach for optimal shunt active power filter control considering alternative performance indices," *IEEE Trans. Power Del.*, vol. 21, no. 1, pp. 406–413, Jan. 2006.
- [5] S. George and V. Agarwal, "A DSP based optimal algorithm for shunt active filter under non sinusoidal supply and unbalanced load conditions," *IEEE Trans. Power Electron.*, vol. 22, no. 2, pp. 593–601, Mar. 2007.
- [6] K. R. Uyyuru, M. K. Mishra, and A. Ghosh, "An optimization-based algorithm for shunt active filter under distorted supply voltages," *IEEE Trans. Power Electron.*, vol. 24, no. 5, pp. 1223–1232, May 2009.
- [7] Parag Kanjiya, Vinod Khadkikar, and Hatem H. Zeineldin, "A Non iterative Optimized Algorithm for Shunt Active Power Filter Under Distorted and Unbalanced Supply Voltages", *IEEE Transactions on Industrial Electronics*, vol. 60, no. 12, pp. 5376- 5390 December 2013.
- [8] IEEE Standard Definitions for the Measurement of Electric Power Quantities under Sinusoidal, Non sinusoidal, Balanced, or Unbalanced Conditions, *IEEE Std. 1459-2010*.
- [9] Mohan Mathur and Rajiv Varma, *Thyristor based FACTS Controllers for Electrical Transmission Systems*", Wiley, 2002.
- [10] Arindam Ghosh and Gerald Ledwich, *Power Quality Enhancement Using Custom Power Devices*, Kluwer Academic Publishers, 2002.