

A DESIGN, CONSTRUCTION AND INSTALLATION OF 1000WATT INVERTER USING SOLAR POWER SYSTEM

Bello Muhammad¹, Hamza Abdullahi², and Sani A. Muhammad³

^{1,2}Department of Electrical/Electronic Engineering, School of Technology,

Kano State Polytechnic

³Department of Computer Engineering, School of Technology, Kano State Polytechnic

ABSTRACT

This Paper research presents design, construction and installation of 1000watts inverter using solar power system. The paper construction/installation provides an alternative source of power supply via solar energy system to power and machine lab/office for three sockets out let and two point of light consequently. The whole papers comprises of 4parts: Solar module, charge/controller, inverter and load.

I INTRODUCTION

Electricity is the most popular form of energy produce in various ways i.e. conventional and non-conventional, which produce power to electrical /electronic devices. In Nigeria, the demand for a system that will guarantee sufficient and reliable supply of electricity has been on for quite a long period but yet not satisfactory. Electricity plays a vital role to human live that cannot be emphasis, starting from how man made his environment, food manufacturing as well as his health. All this can be achieved with the use of electricity. But, unfortunately the aim was not achieve as a result of lack of enough generating plants, lack of good management system in the power holding company of Nigeria PLC (PHCN), Unsustainable and unstable power supply. These some of the problems facing power system in Nigeria. Therefore due to these problems it is good to have an alternating way of getting electricity for human consumptions. Electricity can be obtained in many ways such as. Hydro power plant, nuclear power plants, gas power plant, thermal power plant, and solar power plant. The easiest alternative way is a stand by solar energy. Solar energy is the energy derive from the sunlight strike the panel convert it to Dc and then Inverting circuit it convert the dc to ac signal. Solar energy system always generate electricity by the used of photovoltaic system which consist of the solar cell connected in series. The solar panel uses energy from sun as the primary source. The light from the sun is composes of particles called photons. Photons are small package of pure energy that contains no mass. When sun light strike the surface of a solar cell the energy contained is given to a free electron in the cell. This additional energy causes the electron to cross the junction between the two types of semiconductor material (P-type and N-type) the movement of these electrons constitutes a flow of current. Solar energy is the form of energy transmitted from the sun. This energy is in the form of electromagnetic radiation. The earth receives about one halt of one billionth of the total solar

energy output. According the solar radiation energy in the ultraviolet radiation is 105.8w/m^2 (782% of the solar constant 1353w/m^2) in the visible 640.4w/m^2 (47.33 %) and in the infrared 606.8w/m^2 (44.85%). A solar cell or photovoltaic cell, is a semiconductor device consisting of a large area p-n junction diode which in the presence of sunlight is cable of generating usable, electrical energy this conversion is called the photovoltaic effect. The field of research related to solar cells is known as photovoltaic. Solar cells are particularly well situated which have many applications, and historically used in situations where electrical power from the grid is unavailable such as in remote areas, power systems, earth orbiting satellite hand held calculators, remote radio telephone hones, computer systems, water pumping applications etc. Solar cells (in the form of modules or solar panel) are appearing on building roofs where they are connected through a charge controller. The charge controller controls the charging aspect of the battery so as not to cover charge or discharge to the zero level to the battery, the energy will be stored in the battery while the inverter converts the dc energy stored in the battery to ac $220/240\text{V}$ for the use of the appliances to be powered by electricity from the grid tie.

II MATERIAL AND METHODOLOGY

The paper utilized a photovoltaic (PV) module of 80W; 4.65amps which converts sunlight radiation in to dc power which is stored and discharged from a dry cell battery, a PV load system uses all of the DC part while the AC can be obtained from DC to ac inverter. The methods involved in such projects are as follows:-

- Installing the solar module at the roof of the main office.
- Installing the solar module facing the correct orientations
- Fixing the inverter, charge controller as well as the battery cell in the correct position.

The design procedures and analysis of this paper. In the designing of this project, it was divided into four (4) stage or block. Inverter, ChargeController, Solar Module and Battery cell as shown in fig: 1.0

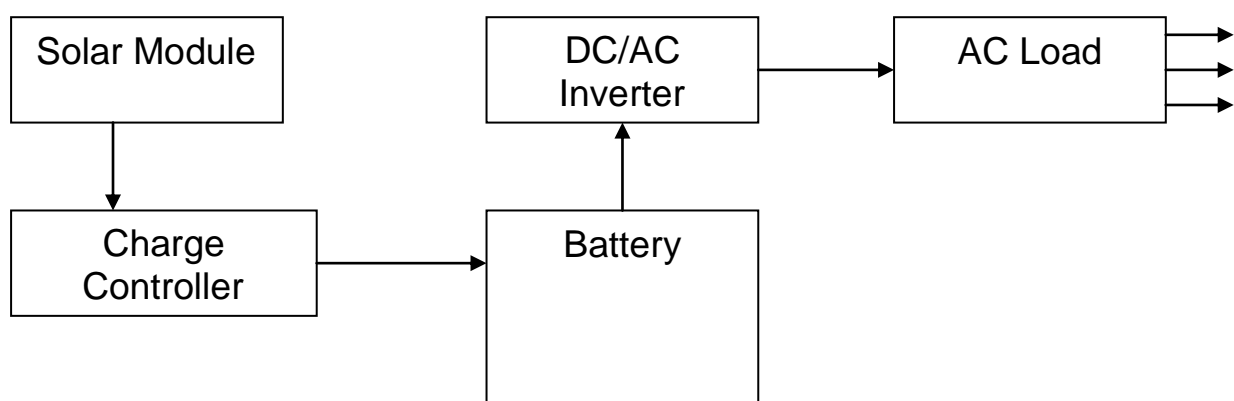

Fig: 1.0

III ANALYSIS OF THE RESULT

The materials for the construction include all components, Vero board and lead. The components were soldered on the Vero board according to the sub circuit arrangement; caution was taken to avoid open or short circuit between component terminal and also between sub circuit connections.

The construction procedure of this project goes from one part to another starting from.

- i. Inverting stageD.C/AC 1000AV.
- ii. Generating stage.....PV module of 80w, 4.5a
- iii. Controlling and changing stagecharger controller of 12V, 15amp
- iv. Accumulating stage.....storage battery 12V, 100AH
- v. Load capacity.....450watt

3.1 Inverter Construction

To construct an inverter one must improvise some materials/components to be used in the constructions. These include the battery, oscillating circuit, switching circuit, charging circuit, transformer and the output.

This sub-circuit arrangement is been arrange in accordance as they are present in block diagram in Fig. 2.0 below. Strippers where used as jointer between them with help of solder and flux.

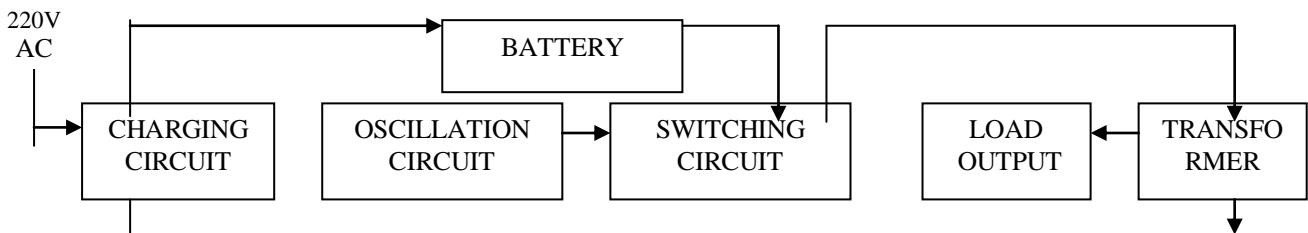

Fig. 2.0 Block diagram of an inverter.

3.2 Solar Panel Installation

Solar panels are typically installed on roof tops, building tops, or stand-alone facilities. It is vital to install your solar panel so that it gets the most direct sun exposure.

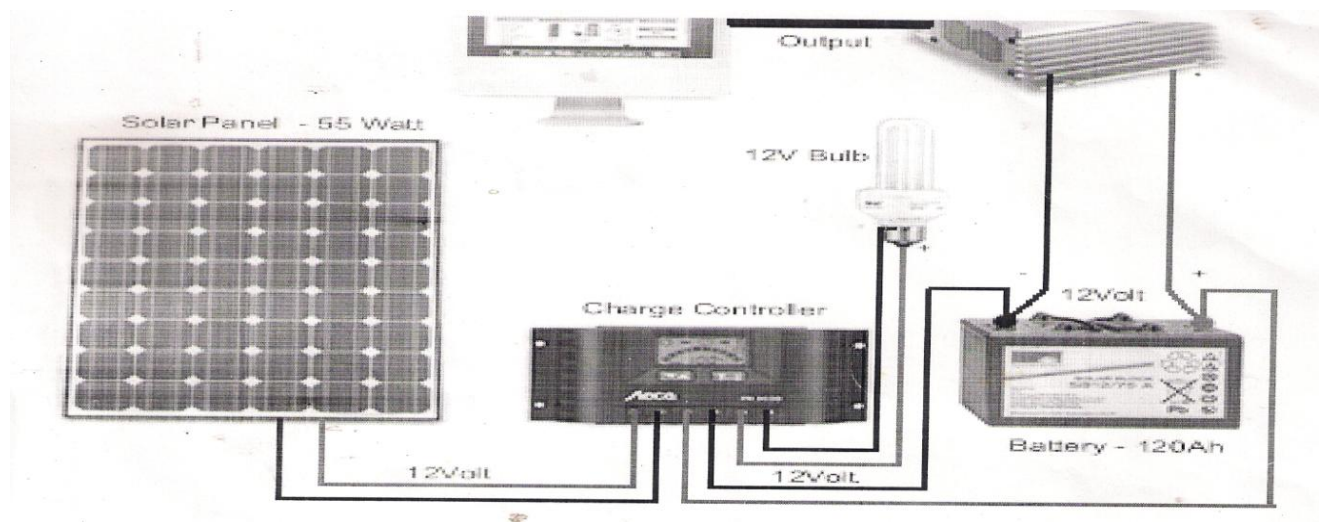

Fig. 3.0 The wiring diagram of solar system.

3.3 Installation Materials

For the installation work cables, chips, nails and screws are used. As in accordance with IEE regulation cable is define as “a length of insulated conductor (Solid or stranded) two or more of such conductor each provided with its insulation which are lead up together. The cable is a back bone for the whole installation work became it used to connect the four deferent systems together while chips, nails and screws are used for mechanical strength and protection. The Installation cable used in this project is 1.5mm² according to IEE regulation; the recommended for lightening installation and 5A fuse should be use for protection. Going by standard (IEE regulation) 1.5mm²cables is recommended for working installation and 5amp fuse should for protect

3.4 Testing

Testing is an important stage for the construction installation of this paper project. Not only satisfactory outcome of the test guarantees the availability of the paper work, rather it meets the requirements and specification of the regulated safety body (i.e IEEE) and also confirmation to the designer of calculation as well as providing with valuable data for future design.

3.5 Results

The solar system was subjected to different type of load, the result is shown in Table 1.0

S/N	TYPE OF LOAD APPLIED	EXPECTED WATTAGE	OUTPUT RESULT/TIME TAKEN
1	No Load	0w	No output time taken is infinity
2	Temperature transducer trainer ST 2302	70w	8Hrs time taken
3	LVDT Trainer ST 2303	60w	10Hrs time taken
4	Strain gauge trainer ST2304	60w	10Hrs time taken
5	DSB/SSB Am transmitter trainer ST 2201	40w	12Hrs time taken
6	DSB/SSBA. M Receiver trainer ST 2202	40w	12Hrs time taken
7	Electronics Boards	50w	11Hrs time taken
8	Laptop	50w	11Hrs time taken
9	Desktop	60w	10Hrs time taken

10	Printer	40w	12hrs time taken
11	Server modem	18w	24Hrs time taken
12	Bulb, energy saver	60w	10Hrs time taken

Table 1.0 showing the result that was conducted.

IV PERFORMANCE EVALUATION

A PV system performance can be calculated based on hours by hour records for the sun. Power of solar panel can generate is 80w, time taken 4 hours. The energy is the product of solar panel watt by the hours ($E = Pt$). the appliances and light bulbs are rated in watts. To work out how much energy an appliance or light will use, you multiply it's wattage by the number of hours it's in use. A battery capacity of 12V, 100AH is measured in amp hours that is used for the storage power source capacity, load were used for testing the sources little after little (i.e 40W – 320W), as it goes on it fails to perform. The battery used to be down within short time, when load reach some certain values. It shows that depending upon the load used as the time it takes. That means longer the time it takes shorter the load apply for the system.

V CONCLUSION AND RECOMMENDATION:

The aim of the work is to provide an alternative source of power supply Via solar energy system, by design and construal a 350W rating inverter, which can be used to drive a load 150W capacity. The construction and the testing of the circuit in the figure were carried out successful, as well as implementation of the design procedure. Although there were problems encountered, but this did not affect the functionality of the project before the testing was conducted, some precautions were taken as follows: -

- i. The circuit was thoroughly checked to ensure that it is for form short circuit and open circuit.
- ii. The circuit diagram was simulated and to minimize error

VI RECOMMENDATIONS

The following recommendations are made for improvement of the work.

1. Using oscillator to get 0% its sinusoidal wave so as to reduce the harmonic distortion which is produced by the square wave
2. Phase shift oscillator circuit could be used so that it changes the square wave to pure some wave form with the help of linear squared low power operational amplifier (SG3524) use.
3. The quality of output waveform that is needed from an inverter depends on the characteristics of the connected load. Some loads a nearly perfect sine wave voltage supply in order to work properly. Other leads may work guide with a square wave voltage.
4. The project should be improved by additional module as to cater for School Internet Cafe.
5. If the low power can be stabilized before passing to the load this will save the load power from fluctuating, problem.

6. Present waveform generator (R2206) could be used so that it change the square wave to pure sine wave form with the help of linear guard low power operational amplifier (2N3055) use.

REFERENCES

- 1) B.I Theraja and A.K. Theraja (1997) "A text book of electrical Technology" S. Chan D. and company Ltd. New Delhi, Twenty Second Edition.
- 2) Comer D.J "electronics Design and integrated circuit "Addition Wesley Canada. Eight Edition 1981
- 3) Morris A. colwell Solar and Hydro Generation 1960
- 4) Solar (Photovoltaic) Electricity: Renewable energy of the future volume 1 by A.S Kurawa. Solar home systems "M.R. Verdant and F.D.J Neiuwenhout.
- 5) Robert L. Boylated and lovicNashewsky (1998)
- 6) "An electronics Devices and circuit theory" person Education singapore PTC, Delhi 110092, Eight Education 2002.
- 7) J.M Gauthier "power supplier switching regulation inventors and converters" (second Edition) Tab Book, (A Division of A.C GrawHilline) 1994
- 8) Manual for the Design and Modification of solar home system Components. By "M. R. Vervaart and FDJ Nieuwenhout".
- 9) Bedford, B. D. Hofe R.G (1964) "Principles of Inverter circuit" New York: John wiley& sons.
- 10) Owen, Edward L. (January/February 1996) "Origins of the inverter" IEEE Industry Applications Magazine: History Department (IEEE).
- 11) Dr. Ulrich Nicolai, Dr. ToblasReimann, Prof. JargenPetzoldt. Power Electronics: "Energy Manager for Hybrid Electric Vehicles"