

ADVANCEMENTS IN AUTOMATIC HAND BRAKE SYSTEM

Sachin S. Dharia¹, Sachin S. Bhopale²
Prathmesh P. Kumbhar³, Kedar S. Pathak⁴

^{1,2}UG Student, Department of Mechanical Engineering,
Dhananjay Mahadik Group of Institutions, Vikaswadi- Kolhapur, (India).

³ UG Student, Department of Mechanical Engineering,
Ashokrao Mane Group of Institutions, Vathar- Kolhapur, (India).

⁴ UG Student, Department of Mechanical Engineering,
KIT Collage of Engineering, Kolhapur, (India).

ABSTRACT

Now a day's automatic hand brake release mechanism has been replaced by the manual hand brake release mechanism. This has taken up an additional use in control of the vehicle by no initiating a rear-wheel skid. The automatic hand brake release mechanism is one of the most effective hand braking system over the conventional systems. This type of mechanism provides totally lever-less operation which saves the effort as well as the space utilization of the vehicle. Generally the hand brake is manually operated whereas in our project work, we have developed an automatic handbrake release mechanism for safety purpose. The engagement and disengagement of the handbrake is done with the help of hydraulic actuators. Moreover when the ignition system is turned off, the solenoid switch gets in and the piston from master cylinder pressurize the oil and then by the means of the hydraulic system it engages the handbrake mechanism. Although sometimes it also known as an emergency brake, using it in any emergency whereas the footbrake is still operational is likely to badly upset the brake balance of the car and vastly increase the likelihood of loss of control of the vehicle, for example by initiating a rear-wheel skid. Additionally, the stopping force provided by using the handbrake is small and would not significantly aid in stopping the vehicle. The hand brake is instead intended for use in case of mechanical failure where the regular footbrake is inoperable or compromised. Modern brake systems are typically very reliable and equipped with dual-circuit hydraulics and low-brake-fluid sensor systems, meaning the handbrake are rarely used to stop a moving vehicle. Comparing with manual handbrake system it has a compact design as well as striking looks having more efficiency. The paper comprises of detail project about Design, Development and Analysis of automatic handbrake release mechanism with having various applications. Taking this criterion into consideration, project is explained along with results which shows how efficient are the automatic handbrakes.

Keywords: Handbrake, Actuators, Solenoid Switch, Master Cylinder

I. INTRODUCTION

The most important part in the automobile is the hand brake which is also known as a latching brake. It is used generally when the automobile is parked, thus the alternative name i.e., parking brakes is used to keep the car stationary also called as automobile e-brakes brake. The most common use of a parking brake is to keep the vehicle motionless when it is parked. Car emergency brakes have a ratchet locking usually consist of a cable directly connected to the brake mechanism this will keep them engaged until a release mechanism button is pressed by the driver. Transmissions, this is usually used in concert with a mechanism is often a hand-operated lever, on the parking pawl in the transmission.

Automotive safety experts recommend the use of both systems to immobilize a parked car, and the use of both systems is required by law in some places yet many individuals use only the "Park" position on the automatic transmission and not the parking brake. It's similar with manual transmission cars: They are recommended always to be left with the handbrake engaged, in concert with their lowest gear (usually either first or reverse). The use of both systems is also required by law in some jurisdictions. However, when parking on level ground, many people either only engage the handbrake (gear lever in neutral), or only select a gear (handbrake released). If parking on a hill with only one system results in the car rolling and damaging the car or other property, insurance companies in some countries, for example in Germany, aren't required to pay for the damages.

Hand brakes are also used to assist in hill starts on vehicles with manual transmissions. Use of the handbrake frees both feet for use on the accelerator and clutch pedals, allowing the car to move off without rolling back at all.

Our project comprises an electric circuit which consists microcontroller, stepper motor and two position sensor. After switching on the ignition and pressing the clutch pedal it automatically releases the hand brake & when the ignition switch turns off it automatically engage the hand brake.

II. AUTOMATIC HANDBRAKE RELEASE MECHANISM

Due to failure of above unit or concept, we decided to change the system and modify it by keeping the purpose same. The newer concept was to introduce PLC Microcontroller along with servomotor which can lead to efficient as well as flexible in design and manipulate the Power Actuator. The use of Power Actuator made our operation easy and risk free.

The construction of newer circuit is much differs from primary one. In this, we eliminated the second master cylinder and used only one master cylinder of regular braking system. We have used the master cylinder of two wheeler disc brake. Because, use of four wheeler master cylinder requires the extra force by Power Actuator, which have a high cost. So, just we replaced it with help of small master cylinder. In regular braking system, the master cylinder is connected to the brake pedal and then to the caliper on disc brake. The difference between regular brake system and an automatic handbrake system is as shown in figure:

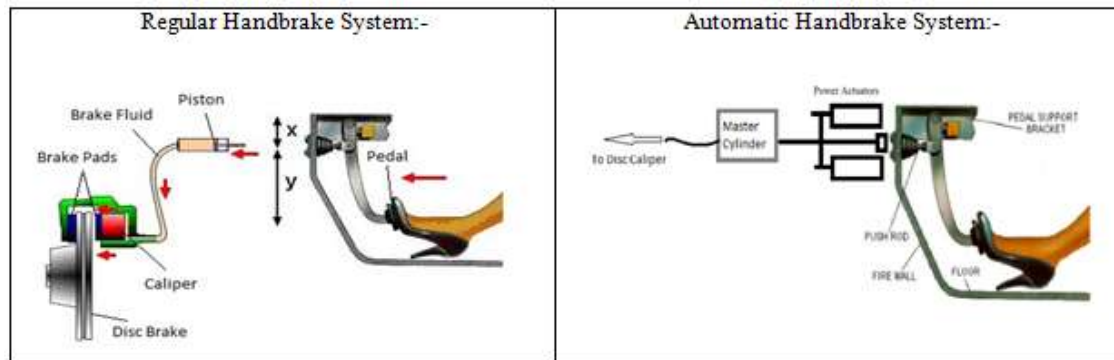

List of components consists of as follows,

- Hydraulic operated braking system i.e., master cylinder
- Parking brake indicator
- Braking –using Disk brake to ensure optimal braking force and minimum braking distance
- Electronically operated solenoid valve
- Power supply unit and recharging unit
- One fixed and one movable power actuator.
- Microcontroller
- Stepper motor

The below figure consist of overall logic diagram of an automatic handbrake release mechanism

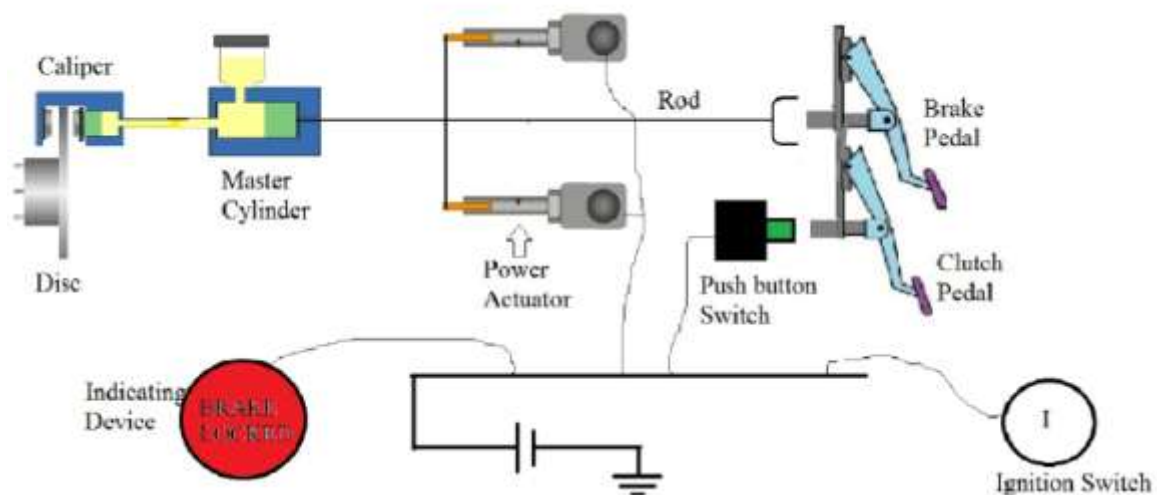

The working basically consist of three conditions as follows,

2.1 Normal running condition:

When the vehicle is normal running condition then, the solenoid valve which is fitted in a fluid supply line is in an on condition. By using microcontroller the solenoid valve energizes and there is regularly flow of fluid supply

as per normal braking action. Fluid passes through master cylinder to the brake disc. In this circuit one way valve is used therefore fluid will not pass through second cylinder i.e. movable cylinder.

2.2 Vehicle at starting condition

When ignition switch is turn on,one signal passes to the microcontroller. Also there must require a clutch signal which acts as a secondary signal then only microcontroller gives command to stepper motor to rotate in clockwise direction. The shaft of that stepper motor is directly connected to moveable cylinder by screw drive. Due to movement of cylinder fluid pressure get releases and brake disengages.

2.3 Ignition switch turning off condition

When ignition switch is turn off, the position sensor sends signal to microcontroller which gives a command to the solenoid valve and stepper motor. Moreover, at that time solenoid valve will be in closed position. Stepper motor will rotate in clockwise direction whereasmovable cylinder moves backward and fluid gets pressurized therefore brakegets applied.

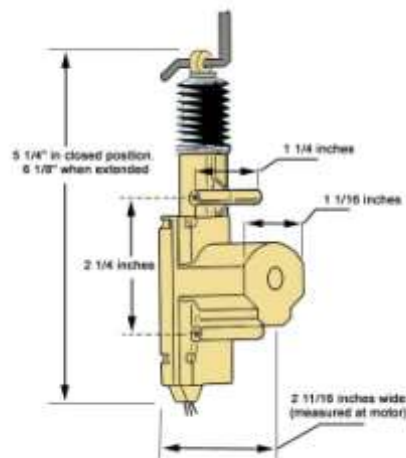

Figure: Overall assembly

Main designed components of automatic handbrake release mechanism has been designed and manipulated in the figures as given below,

- Power Actuator

We have used power door actuator as Power Actuator. A small electric turns a series of spur gears that serve as a gear reduction. The last gear drives a rack-and-pinion gear set that is connected to the actuator rod. The rack converts the rotational motion of the motor into the linear motion needed to move the lock. In this mechanism the motor can turn the gears as well as move the latch. This is accomplished by a clutch that is connected to the gear and engaged by the motor.



- Master Cylinder

In brake systems, the operated devices are cylinders inside of brake calipers and/or drumbrakes; these cylinders may be called wheel cylinders or slave cylinders, and they push the brake pads towards a surface that rotates with the wheel (this surface is typically either a drum, or a disc) until the stationary brake pads create friction against that rotating surface (typically the rotating surface is metal or ceramic/carbon, for their ability to withstand heat and friction without wearing-down rapidly).

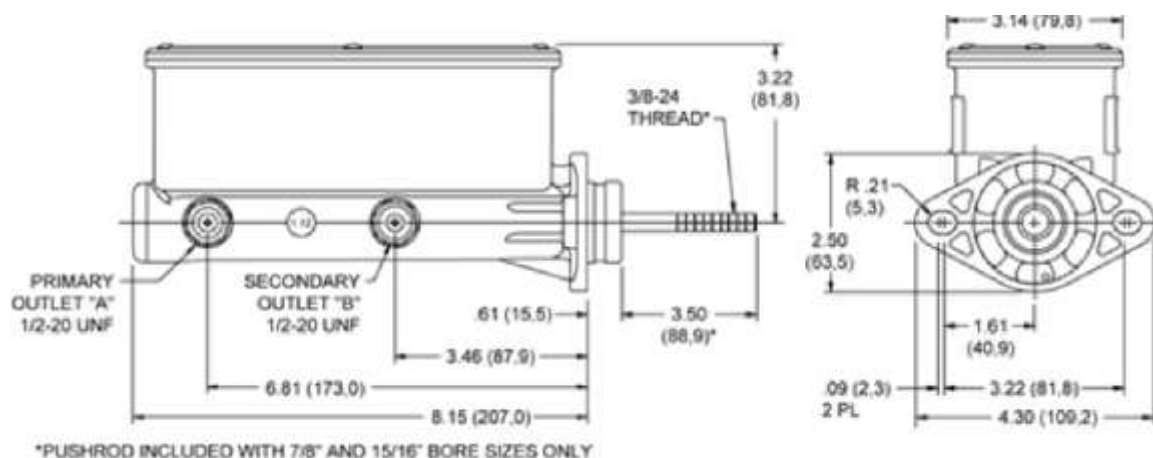

Dimensions of brake cylinder

III. DESIGN AND CALCULATIONS

3.1 Design of Frame

The Frame fabricated for our project which is made up of M.S. It is welded accordingly for arrangement of the system components. The Frame along with dimension is shown in figure below:

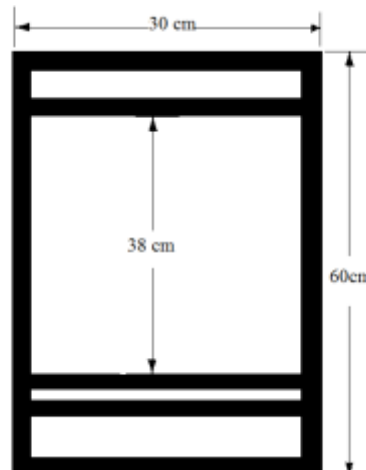

Fig. Frame Construction

Frame Specification:

- Size of Frame: 60 x 30 mm
- Material of Frame: Mild Steel
- Unloaded Weight of Frame: 2.65 kg
- Loaded weight of frame: 9.7 kg

3.2 Force Calculation

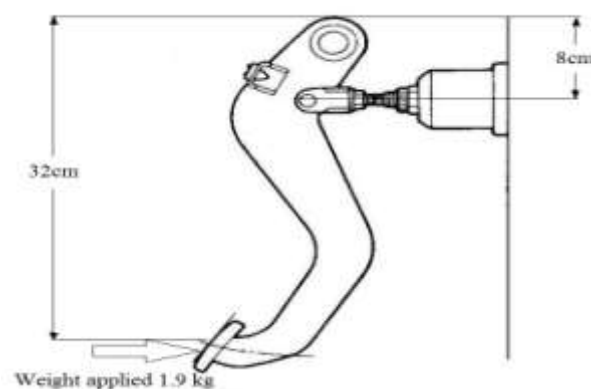

Fig. Dimension and Force applied

By lever principal:

$$32 \times 1.9 = 8 \times A$$

$$60.8 \div 8 = A$$

$$A = 7.6 \text{ kg}$$

$$A = 74.556 \text{ N.}$$

Applying Pascal's law:

i.e., "Pressure exerted on a confined liquid is transmitted undiminished in all directions and acts at right angles with equal force on all areas of the container".

$$P = F \div A$$

$$P = 74.556 \div [(\pi/4) \times (12.7)^2]$$

$$P = 0.588 \text{ N/mm}^2$$

The intensity of pressure is constant throughout system,

For caliper:

There are two cylinders in caliper.

Therefore, force for one cylinder is:

$$F = P \times A$$

$$F = 0.588 \times [(\pi/4) \times 25^2]$$

$$F = 288.63 \text{ N.}$$

But the force is applied by two cylinders, so force developed by 2 cylinders is:

$$288.63 + 288.63 = 577.20 \text{ N.}$$

In case of handbrake, generally only 60% of handbrake we use while braking instead of total brake. So force required for handbrake is 60% of total.

Therefore, 60% of total brake is,

$$0.6 \times 74.55 = 44.73 \text{ N}$$

Now, for our automatic handbrake system, we have to choose an actuator which will produce nearby 45 N of force.

IV. DRAWING ASSEMBLY AND TABLES

4.1 Actuator Arrangement Design

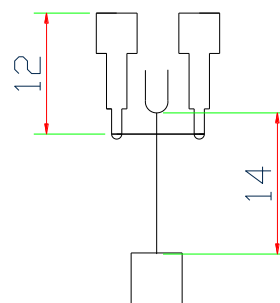

Fig. Actuator Arrangement

4.2 Assembly Design On Frame

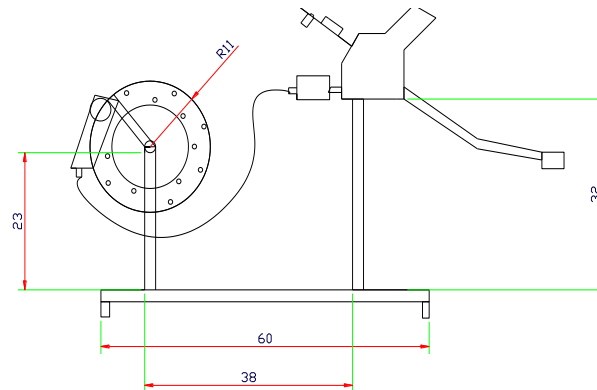

Fig. Assembly of Project Design

V. COST ESTIMATION

SR NO.	LIST OF COMPONENTS	QUANTITY	PRICE
1	Master Cylinder of two wheeler	1	1800
2	Disc Caliper	1	1700
3	Aluminum hose	1	420
4	Power Actuator	2	2200
5	Pedal Assembly	1	945
6	Press switch	1	167
7	Disc Assembly	1	1314
8	Ignition Switch	1	768
9	Frame	1	1050
10	Fabrication	-	650
11	Painting	-	350
12	Indicating Device	1	250
13	Battery	1	1200
14	Miscellaneous Cost		5000
Total Cost			17814/-

VI. CONCLUSIONS

- Automatic hand brake release mechanism is beneficial for operator's safety by reducing accident chances as well as disengaging chances of braking. This system can also be used in commercial cars for ease of operating as well for reducing cost purpose.

4th International Conference on Science, Technology and Management

India International Centre, New Delhi

(ICSTM-16)

15th May 2016, www.conferenceworld.in

ISBN: 978-81-932074-8-2

- Along with it, we can also modify our system by using the spring at the power actuator by using it as reverse purpose. Thus, our project is still a demonstration of it, no car has yet used such concept on ignition switch.
- This project gives a new idea of automatic hand braking system which can be applied in car manufacturing industries as well as companies.
- The working is quite simple and doesn't require any extra effort to operator or driver.
- Even though when any driver forgets to pull the hand brake in regular car, the driver can be in any critical situation but by using the concept of automatic handbrake system, there is no possibility of risk because by putting the ignition switch OFF, the hand brake system is automatically gets locked.

REFERENCES

- [1] "Full power hydraulic brake actuation, circuit design considerations for off-highway vehicles and equipment" by D. E. Keyser, MICO Incorporated, 1911 Lee Boulevard, North Mankato Minnesota USA 56003-250.
- [2] "Optimization of the composing part of hand brake mechanism" by S. Economic, a Co-operating with E. Saric.
- [3] "The 8051 microcontroller and embedded systems" by Muhammad Ali Mazidi, Janice GillispiceMazidi and Rolin D. Mckinlay.
- [4] "Introduction to machine design" by 'V. B. Bhandari'.
- [5] "Introduction to Mechatronics" by K.C. Kali.
- [6] "Industrial Fluid Power" by 'C. P. Murgudkar'.