

WHEEL CHAIR & INDUSTRIAL DEVICES CONTROL USING ANDROID MOBILE AND BLUETOOTH

**Uttara Raghunath Chaudhari¹, Sayali Kamlakar Pisolkar²,
Mokshada Kishor Gajare³, Amol Manghale⁴**

*^{1,2,3,4} Electrical department, Guru Gobind Singh Polytechnic, Nashik,
Maharashtra, (India)*

ABSTRACT

This project has integration of Android mobile technology and embedded system. Android mobile user has to install an application on his mobile handset to control the devices. Then he/she can give command using the buttons on that application. For this you have to turn on the Bluetooth on mobile, so the main wireless controlling technique used in this project is Bluetooth technology. Bluetooth receiver will be connected to the project. This Bluetooth device is connected to the circuit which has a decoder. It sends out a code for respective command sent by user. This system then recognize the particular input through microcontroller and help the physically handicap person to operate his wheelchair at the same time he can also operate all the home appliances, Then the respective device connected to the circuit will be turned on or off depending on the command given. For example, turn on motor, Turn off motor etc. Such that by giving commands from mobile you can control industrial work.

I. INTRODUCTION

In fast moving world, time is most important factor. You can turn on/off device in the industry by giving command through cell phone. It will save time as well as manpower required to control industrial devices. By using key command on android mobile we can control six devices. We can increase the number of devices. Most important factor about this project is that it is controlled using an application on android mobile. The person who has installed this application on his/her android mobile can only interfere in the controlling devices. Also it removes the need of carrying a remote control to turn on/off the devices.

This project has integration of Android mobile technology and embedded system. Android mobile user has to install an application on his/her mobile handset to control the devices. Then he/she can give command using the buttons on that application. For this you have to turn on the Bluetooth on mobile, so the main wireless controlling technique used in this project is Bluetooth technology. Bluetooth receiver will be connected to the project. This Bluetooth device is connected to the circuit which has a decoder. It sends out a code for respective command sent by user. Then the respective device connected to the circuit will be turned on or off depending on the command given. For example turn on Fan, Turn off Fan. Turn on buzzer etc. Such that by giving commands from mobile you can control industrial work

This is more advantages, when we have to turn on the machinery at the time when we have another urgent task to do and we cannot get up from our place. In this case we can turn on machinery by giving simply command through mobile phone. There is no need to go to field.

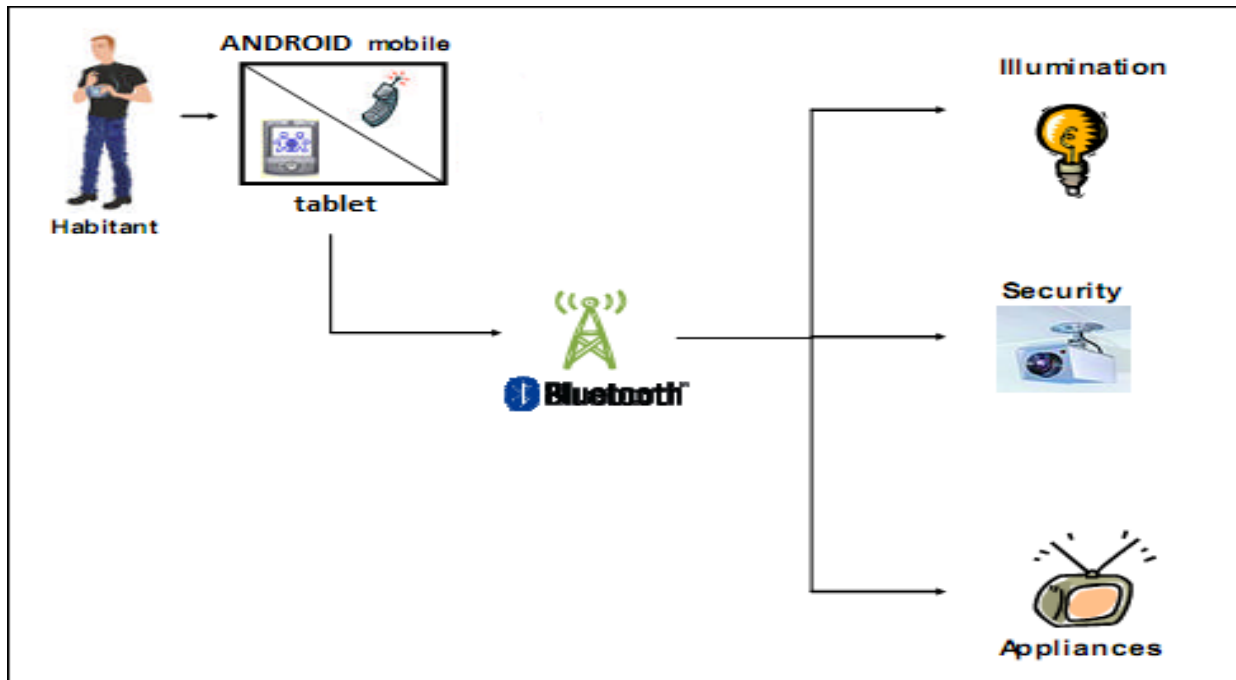

II.BLOCK DIAGRAM

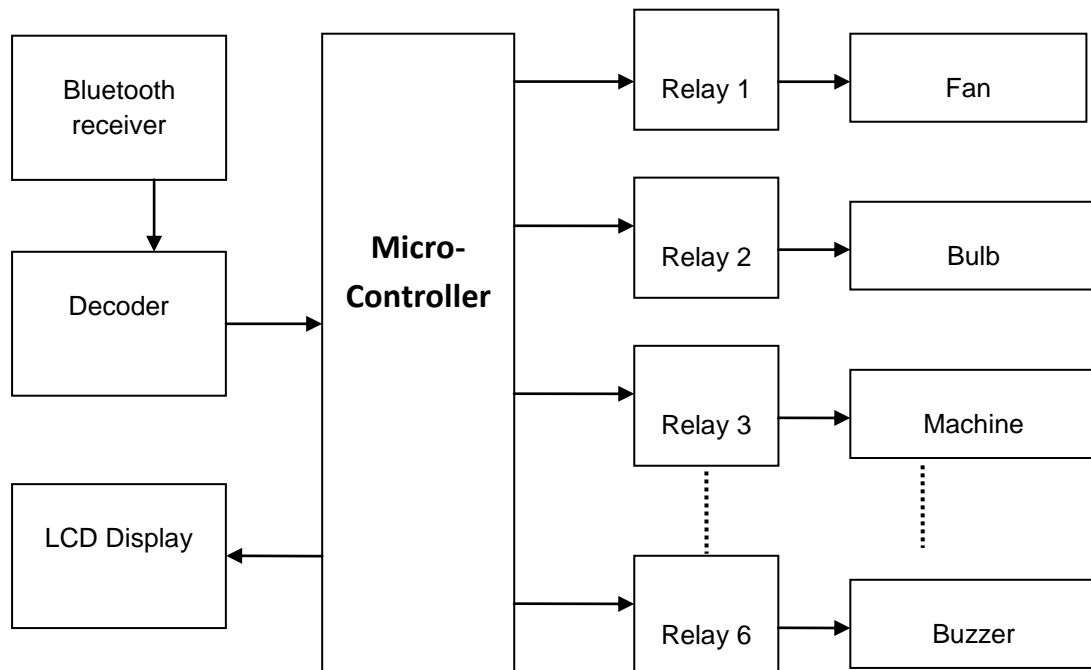

1) MICRO-CONTROLLER (8051)

It is the major part of the system. It maintains the temperature, humidity and light intensity to the desired value. The 8051 has one serial port that receives and transmits data. Transmission and reception can take place simultaneously. The four communication modes possible with 8051 present the system designer and programmer with opportunities to conduct very sophisticated data communication network. It is the heart of the system which controls all the inputs and the controlling action to be taken at the output. Microcontroller used here is the AT89S51.

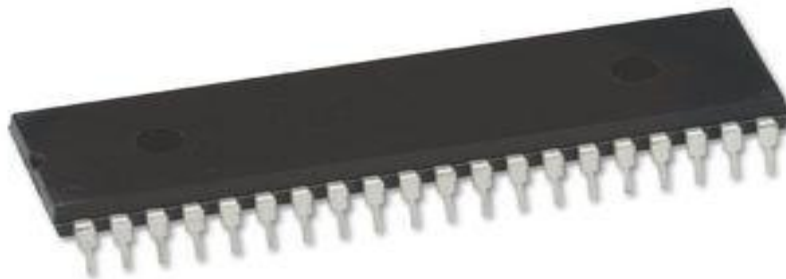

Figure: Photograph of an 89s51 microcontroller.

We are using 8051 AT89S51 Microcontroller. The AT89S51 microcontroller is a 40 pin DIP (Dual Inline Package) chip.

Features:-

- High-performance, Low-power 8051
- Advanced RISC Architecture
 - 131 Powerful Instructions – Most Single-clock Cycle Execution
 - 32 x 8 General Purpose Working Registers
 - Fully Static Operation
 - Up to 16 MIPS Throughput at 16 MHz
 - On-chip 2-cycle Multiplier

2) DISPLAY

It is used to display the current values of the measuring quantities. It can be used to display the various options and all the readings that have been stored in the EEPROM. LCD or 7 segment LED display can be used. Here the LCD used is the 16x2 line LCD. We can also use 16x4 line LCD. Liquid Crystal Display which is commonly known as LCD is an Alphanumeric Display it means that it can display Alphabets, Numbers as well as special symbols thus LCD is a user friendly Display device which can be used for displaying various messages unlike seven segment display which can display only numbers and some of the alphabets. The only disadvantage of LCD over seven segment is that seven segment is robust display and be visualized from a

longer distance as compared to LCD. Here I have used 16 x 2 Alphanumeric Display which means on this display I can display two lines with maximum of 16 characters in one line.

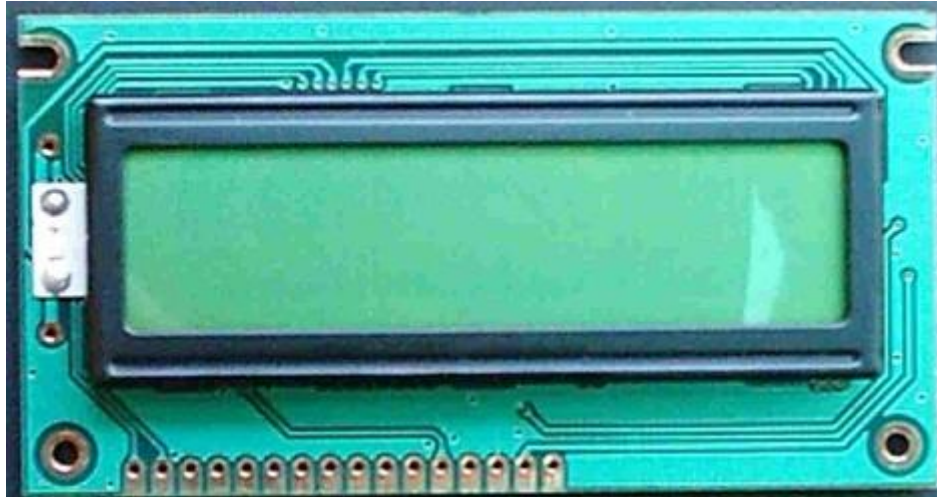

Figure: Photograph of A typical 16 by 2 alphanumeric LCD display

LCD stands for Liquid Crystal Display. The most commonly used LCDs found in the market today are 1 Line, 2 Line or 4 Line LCDs which have only 1 controller and support at most of 80 characters.

3) Mobile

It consists of an android mobile handset having Bluetooth. Also user needs to install an application on this mobile. This android mobile will send command using the Bluetooth technology.

4) Bluetooth decoder

It consists of Bluetooth decoder. It gives ASCII code output. This receiver enables wireless transmission & reception of serial data. It has 10 meters range.

5) Relay

Relay is used to control the on/off operation of device. Relays are driven by the transistors. We are using single pole double throw (SPDT) relay.

To perform switching of relay transistor BC 548 is used

- 1) Relay can switch AC & DC, whereas transistor can only switch DC.
- 2) Relays can switch high voltage, transistor cannot.
- 3) Relays are a better choice for switching large currents (i.e. >5A).
- 4) Relays can switch many contacts at once.

Relay acts as a switch which is used to control the 230 volt AC supply. This relay will be turned off if there is no person inside the room. This relay can be used to turn off the electrical appliances like fan, tubes etc.



Figure: Photograph of a typical 12volt relay

Relays are components which allow a low-power circuit to switch a relatively high current on and off, or to control signals that must be electrically isolated from the controlling circuit itself. To make a relay operate, we have to pass a suitable pull-in and holding current (DC) through its energizing coil. And generally relay coils are designed to operate from a particular supply voltage, often 12V, in case of many small relays used for electronics work.

III. RELAY DRIVER CIRCUIT

We have to provide enough base current to turn the transistor on and off. NPN transistor BC547 is used to control a Relay with a 12V coil, operating from a +12V supply. Series base resistor R1 is used to set the base current for transistor, so that the transistor is driven into saturation (fully turned on) when the relay is to be energized. Thus the transistor will have minimal voltage drop, and hence dissipate very little power as well as delivering most of the 12V to the relay coil.

Basic transistor relay driver, actuated on HIGH input (NPN)

This circuit will drive a relay coil from a low power output, usually from an IC like 89s51. It is used to switch high loads or a load that needs AC current to operate. The relay will be actuated when the input of the circuit goes high. The protection diode Dp is used to protect the transistor from the reverse current generated from the coil of the relay during the switch off time. The values for Rb and Qs vary accordingly.

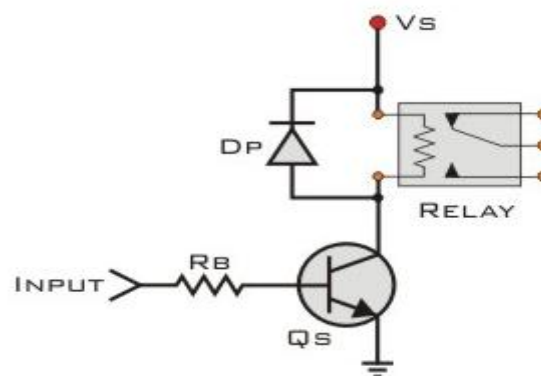

What is Bluetooth?

Bluetooth is a wireless technology used to transfer data between different electronic devices. The distance of data transmission is small in comparison to other modes of wireless communication. This technology eradicates the use of cords, cables, adapters and permits the electronic devices to communicate wirelessly among each other.

The key features of Bluetooth technology:

- Less complication
- Less power consumption
- Available at cheaper rates
- Robustness

Bluetooth technology permits hands free headset for incoming voice calls, ability of printing and fax, and automatic synchronization of PDA.

Bluetooth Decoder

This module enables you to wireless transmit & receive serial data. It is a drop in replacement for wired serial connections allowing transparent two way data communication. You can simply use it for serial port replacement to establish connection between MCU or embedded project and PC for data transfer. This board operates on 5V and has LED indication.

Features

- 5V power operation
- UART interface
- 10 meters range
- Status LED

Product Specifications

- Bluetooth protocol v2.0
- Baud Rate: 9600 bits per second
- Power Supply: +5 VDC 50mA
- Operating Temperature: -20C to +55 C
- Dimensions: 26.9 mm x 13 mm x 2.2 mm

POWER SUPPLY

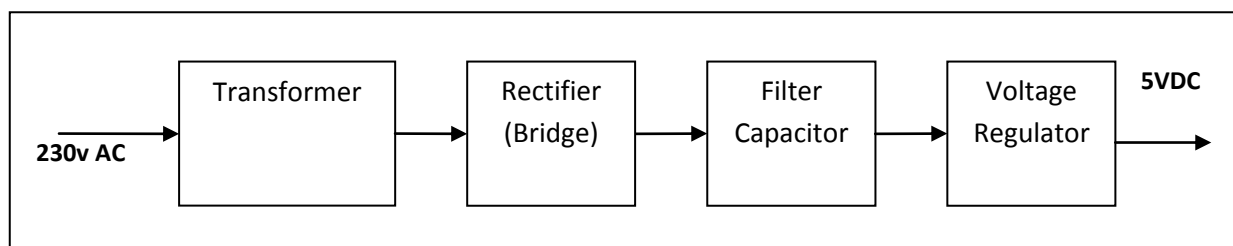

Fig. shows the block diagram of a typical power supply. The AC mains is given to the transformer primary to get the required voltage at the secondary. Then it is applied to the bridge rectifier, which converts the sinusoidal input into full wave rectified output. The output of the rectifier contains some ripple voltage. To remove this voltage filter circuit is used. A ripple voltage is nothing but a small value of AC over DC signal. Then a pure DC is given to the regulator. The function of the regulator is to give the constant or stable output DC in spite of changes in the load current.

IV. RESULT & CONCLUSION

4.1 Result

SR No.	Key	Device(demo)	Device(field)	Function
1	1	Bulb	Motor1	Turn on
2	2	Fan	Boiler	Turn on
3	3	Buzzer	Machinery	Turn on
4	4		Fan	Turn on
5	5		Motor2	Turn on
6	6		Lights	Turn on
7	7	Bulb	Motor1	Turn off
8	8	Fan	Boiler	Turn off
9	9	Buzzer	Machinery	Turn off
10	0		Fan	Turn off
11	*		Motor2	Turn off
12	#		Lights	Turn off

4.2 Conclusion

With the knowledge of new techniques in ‘Electronics’ we are able to make our life more comfortable. One such application of electronics is used in “Bluetooth controlled industrial devices using Android mobile” The approach we followed and which is explained in this project report is novel and has achieved the target of “Bluetooth controlled industrial devices using Android mobile” satisfying user needs and requirements.

REFERENCE

- [1]Rajesh KannanMegalingam, Ramesh Nammily Nair, SaiManojPrakhya,” Automated Voice based Home Navigation System for the Elderly and the Physically Challenged”, Feb. 13~16, 2011 ICACT201, pp.603
- [2]P.Sutha, S. Prabhu, S. Manikandan,S. Venkateshkumar, A. Stephen paul. International Journal of Engineering and Innovative Technology (IJEIT) Volume 2, Issue 12, June 2013
- [3]K. Sudheer, T.V.Janardhanarao, CH. Srhidevi, M.S.MadhanMohan,Voice and Gesture Based Electric - Powered Wheelchair Using ARM2278-5841, Vol 1, Issue 6, November 2012.
- [4]HaoyunXue, Shengfeng Qin, Mobile Motion Gesture Design for Deaf People, 17th International Conference on Automation andComputing, University of Huddersfield, Huddersfield, UK,10 September 2011
- [5]JinhuaZeng, Yaoru Sun, and Fang Wang,A natural hand gesture system for intelligent human-computer interaction and medical-assistance,978-0-7695-4860-9/12 \$26.00 © 2012 IEEE DOI10.1109/GCIS.2012.60
- [6]BojanMrazovac*, Milan Z. Bjelica*, DjordjeSimić**, SrdjanTikvić** and Ištvan Papp* Gesture Based Hardware Interface for RF Lighting Control ©2011 IEEE
- [7]DikshaGoyal and Dr. S.P.S. SainiAccelerometer Based Hand Gesture Controlled Wheelchair, International Journal on Emerging Technologies 4(2): 15-20(2013Android Programmers Guide by Jerome DiMarzio