

FLEX SENSOR BASED ROBOTIC ARM CONTROLLER: DEVELOPMENT

Jagtap Gautami¹, Alve Sampada², Malhotra Sahil³, Pankaj Dadhich⁴

Electronics and Telecommunication Department, Guru Gobind Singh Polytechnic, Nashik (India)

ABSTRACT

In today's world there is an increasing need to create artificial arm for different inhuman situation where human interaction is difficult or impossible. Sensor plays an important role in robotics. Sensors are used to determine the current state of the system. In Robotic world required sensors with high degrees of repeatability, precision, and reliability. Flex sensor is such a device, which accomplish the above task with great degree of accuracy.

Keywords : *Flex Sensors; ADC; Data Glove (DG); Microcontroller; DOF (Degree Of Freedom)*

I INTRODUCTION

A robotic arm is a robot, usually programmable with similar functions to a human arm. Earlier days, robots are increasingly being integrated into working tasks to replace humans especially to perform some task. Some companies have designed units, which can integrate accelerometers, magnetometers and can be attached to human limbs. These units can be worn for video game character modelling [1], virtual reality [2,3], activity recognition [4]. To capture the motion of human limbs, sensors are used. In simple words this mechanical hand will always copy my hand movements. This type of system is very useful in fields of medical, defense and industrial works where delicate and dangerous task can be done from a distance without actually touching.

II LITERATURE SURVEY

We have gone through some of the papers related to our project and found some advantages of our system over the existing system. The development of Robotics is responsible for create artificial arm for different inhuman situation where human interaction is difficult or impossible [6]. The project is implemented with micro controller ATmega328 (inbuilt ADC) and Flex sensor. When the object is bent the sensor produces a resistance output relative to the bend radius [2]. Servo motors are a type of electromechanical actuators that do not rotate continuously like DC/AC or stepper motors.

Our project is one of major improvements because of its advanced technology. This system is expert at multi-application.

III STRUCTURE

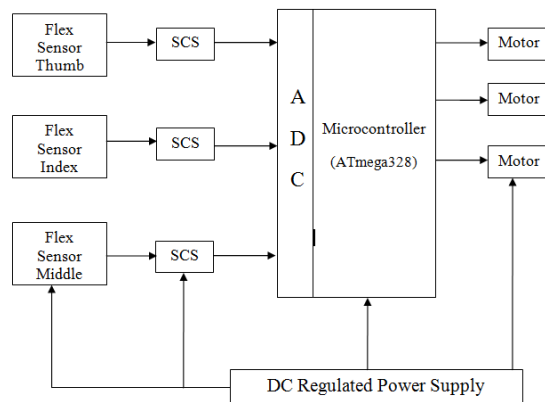

Figure 1. Structure of Flex sensor based Robotic arm controller

FLEX SENSOR

Flex sensor is also called as bend sensor. That is capable of sensing any kind of minute bend in its structure. Flex sensor is designed in a thin plastic strip type material. Carbon layer is divided into small sections and connected together in series by conductive layer. These sensors are analog resistors. They work as variable analog voltage divider. When the substrate is bent the sensor produces a resistance output relative to the bend radius[2].

MICROCONTROLLER

The action of Robotic arm is controlled by Microcontroller. It receives input variation of flex sensor through Analog to Digital Converter, which is given in form of proportional current variation to motors attached to robotic arm.

ADC

The device features a 10-bit successive approximation ADC. The ADC is connected to an 8-channel Analog Multiplexer which allows eight single-ended voltage inputs constructed from the pins of Port A. The single-ended voltage inputs refer to 0V (GND). The ADC contains a Sample and Hold circuit which ensures that the input voltage to the ADC is held at a constant level during conversion.

Servo Motor

Servo motors are a type of electromechanical actuators that do not rotate continuously like DC/AC or stepper motors; rather, they are used to position and hold some object. They are used where continuous rotation is not required so they are not used to drive wheels (unless a servo is modified).

Power Supply

The signal is passed through the Step down transformer. And Transformer give the output to Full wave rectifier. It converts the input signal into pulsating DC. Rectifier output is converted into pure DC by using filter. The voltage regulator is a specially designed circuit to keep the output voltage constant.

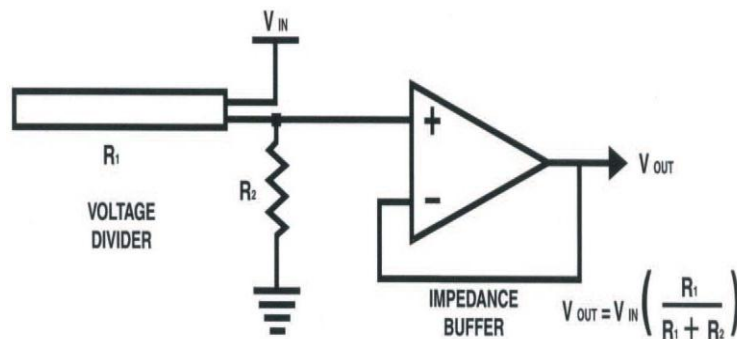

Figure2. Flex Sensor Basic circuit

IV FLOW OF ACTION FOR THE ROBOTIC ARM

- Read values of the Flex sensor;
- Micro controller processes the Flex sensor values;
- Send values from microcontroller to motors;
- Pick up the objects;
- Place at the required position;
- Bring arm at original position.

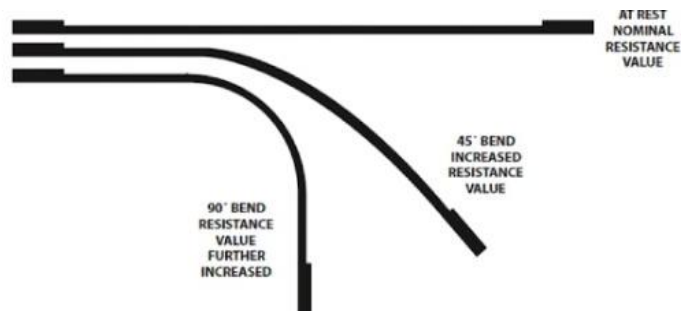

Figure3. Flex Sensor Bend proportional to varying degree of resistance

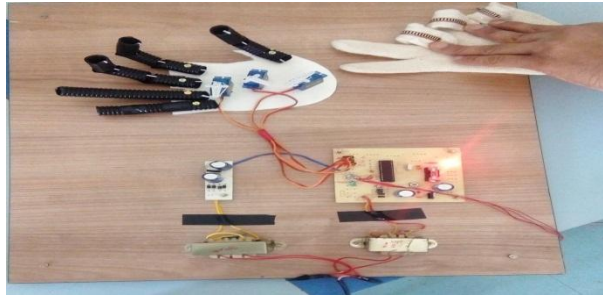

Figure4. Implemented Flex sensor based Robotic arm controller

V APPLICATIONS

Military:It can be used for bomb diffuse robots. Where human operation can be life costly, in such situation this type of mechanical hand can be operated over safe distance.

Industrial:It can be used in place operate with hazardous and dangerous material which will be not being safe for human hands to handle.

Medical:Robotic hand can also be used in hospitals where doctor can perform complex operation from far distant places.

Space Exploration:Robotic Hand can be used in space exploration where such robots can remotely operate and do the lab work, this will save lots of money and can also be used for very long missions which humans cannot.

VI ADVANTAGES

Expert at Multi application:In chemical industry, Military, and Medical it can perform complex surgical operations.

Saving:Improve worker safety leads to financial saving. Their movement are always exact, minimizing material waste and save time.

Reliability:The ability of a system to perform required function under stated condition for specified time.

Safety:Increase workplace safety. Worker no longer have to perform dangerous application in hazardous setting.

VII CONCLUSION AND FUTURE SCOPE

In this document,This Robotic arm is very useful for the society and also in industrial application and it works successfully at the time of demonstration.Micro controller programming can be done with an ease to suit the requirements. Unlike [7]

which employ FPGA based control. Micro controller based programs can be flexibly modified to suit the necessary drive control of the servo motor. In future it will work on wireless technology.

REFERENCES

- [1] C. Edwards and E. Smith, "Design of Simulink-Based 2- DOF Robot Arm Control Workstation," 31 October 2006.
- [2] E. Foxl and L. Naimark, "Vis-Tracker: A Wearable Vision-Inertial Self-Tracker," IEEE Virtual Reality Conference, 22-26 March 2003, Los Angeles.
- [3] D. Fontaine, D. David and Y. Caritu, "Sourceless Human Body Motion Capture," *Smart Objects Conference (SOC 2003)*, Grenoble, 2003.
- [4] *Journal of Software Engineering and Applications*, 2012, 5, 364-366 <http://dx.doi.org/10.4236/jsea.2012.5504>
Published Online May2012 (<http://www.SciRP.org/journal/jsea>)
- [5] J. Bernstein, H. R. Everett, L. Feng, and D. Wehe, "Mo-bile Robot Positioning Sensors & Techniques," *Journal of Robotic Systems, Special Issue on Mobile Robots*, Vol. 14, No. 4, pp. 231-249.
- [6] International Journal of Advanced Research in Electronics and Communication Engineering (IJARECE) Volume 4, Issue 12, December 2015
- [7] M.R. Cutkosky, "On Grasp Choice, Grasp Models, and the Design of Hands for Manufacturing," IEEE Transactions on Robotics and Automation. Vol. 5, pp. 269-279, 1989