

CONTROL OF ELECTRIC HOIST USING SMARTPHONE IN INDUSTRIAL ENVIRONMENT

Prasad Deore¹, Anish Thiya², Swapnil Ahire³

¹Department of Electrical Engineering, LGNSCOE, Nashik, (India)

²Department of Electrical Engineering, SIEM, Nashik, (India)

³Department of Electrical Engineering, SIEM, Nashik, (India)

ABSTRACT

This paper presents the implementation of electric hoist using a control operation based on Arduino board and Bluetooth module. It control the functions of movement and direction such as pick and release, up and down, and left or right with its relay-supporting dc voltage. relay control on-off operation is effective to variation of rotation of the motor. The remote control is based on a smart phone application based on android platform with a Bluetooth connectivity used as an transmission as well as reception ports with Arduino module. With the introduction of Bluetooth, another dimension is aggregated, the possibility to connect to the devices wireless. The technology makes it possible to easily access the built-in user interfaces through portable devices but also to access the device data without the need for a physical connection.

Keywords : Android App, Arduino Board, Bluetooth, Electric Power Supply, Industrial Electric Hoist Model, Relay Control Circuit, Smart Phone.

I INTRODUCTION

The application of wireless controlled systems to industrial systems has grown in a spectacular way. One of the current challenges in this field is the application of the wireless technology, because it is looked for that the industrial-systems are flexible, so that they can be adapted easily to any process modifications. This would at low, in turn, the definition of generic modules that could be adapted to concrete problems. Then, it seems very important, the application of wireless control systems, so that without cables we have a much greater freedom to physically distribute the operations. In this system the Arduino Uno acts as the main controller and the Bluetooth module acts as the interface between the android application and the Arduino Module. The voice recognition app ;i.e 'AMR_Voice' and the touch control app; 'BluControl' is readily available in the Android app market, which is specifically used in this process. When transmitting or receiving from rotating and moving machine parts, it is of great advantage to use wireless communication. Bluetooth in industry impose new requirements on the technology, while it at the same time opens up new and interesting possibilities for using wireless communications in industrial applications. The Bluetooth technology uses the short range radio communication

to operate and hence has a short range of operation. In the current scenario, the operator has to operate the hoist to its desired point by manually moving with it; hence the operator has to follow the hoist on the work floor which in sometime is a great mess. So in this paper we are going to resolve this problem by introducing the combination of Bluetooth, Arduino and the android platform in such a way that we can operate the hoist wirelessly from a fixed point.

II ARDUINO



Fig.2.1 Arduino Uno Chipset

The Arduino Uno is a micro-controller board based on the ATmega328. It has 14 digital input/output pins (of which 6 can be used as PWM outputs), 6 analog inputs, a 16 MHz crystal oscillator, a USB connection, a power jack, an ICSP header, and a reset button. It contains everything needed to support the micro-controller; simply connect it to a computer with a USB cable or power it with a AC-to-DC adapter or battery to get started. The Arduino is interfaced to the Bluetooth module which acts as the receptor which receives the commands transmitted from the smart phone. As per the command transmitted and received by the module, the Arduino controls the counterpart which is here the electric hoist motor. We are

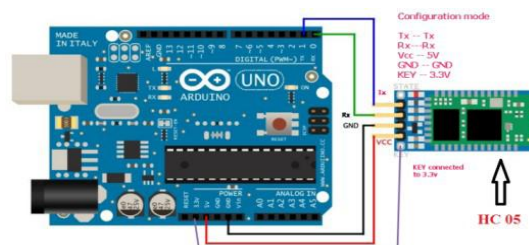

Fig.2.2 Arduino and HC-05 Interface

using the Arduino Uno micro-controller because it provides a multilevel scope for operation of multiple operands connected to it. It has an inbuilt Digital-Analog converter which is very helpful to run the electric motors through relays or even without it.

III BLUETOOTH

Bluetooth is a standard for short-range radio and personal area networks, developed by the Bluetooth Special Interest Group(SIG). The Bluetooth SIG is supported by a number of large multinational companies, This group of companies cooperate, to make the Bluetooth standard accepted and compatible worldwide.The Bluetooth standard uses the Industrial Scientific Medicine radio band (ISM) 2.45 GHz. The required and nominal range is 10m (transmit power 0 dBm, 1 mw) and an external power amplifier can be added which gives an extended range up to 100m (transmit power 20 dBm 100 mw). Bluetooth supports point to point and point to multi-point

connections. The Bluetooth technology opens up new possibilities for using wireless communication in industrial environments. Wireless networks have some inherent advantages and limitations, that should be considered carefully when utilizing wireless technology in control systems. The main advantages are the no necessity of cables, the possibility of implement mobile applications and flexibility. In the other hand, the main disadvantages are the interference with other devices in the same radio frequency band and security.

3.1 Bluetooth module HC-05

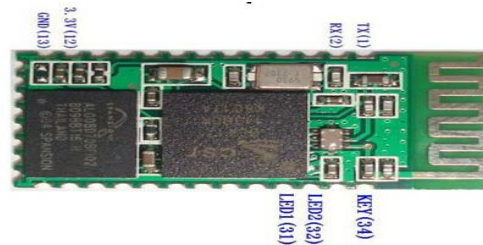

Fig.3.1 Bluetooth Module HC-05

The Bluetooth module contains 4-pins generally. Two pins are used to provide power to the device, hence are connected to Vee and ground. The other two pins are used for transmission and reception of serial data. The "TX" (transmission) pin of the Bluetooth module is connected to a digital pin of micro-controller used for receiving the data and the "RX" (reception) pin of the Bluetooth module is connected to a digital pin of Arduino board used to transmit the data. This setup facilitates serial communication of data wirelessly. This module acts as a mediator which receives the signal from the smart phone and sends that signal to the Arduino board.

IV ANDROID APPLICATIONS

The 80% of the smart phone runs on the android platform and also the android is one of the best customizable platform that can be used for many useful purposes. Hence we are using two of the android application ; 'AMR_Voice' & 'BluControl' respectively for the wireless operation of the hoist. The 'AMR_Voice' application is for the Voice control whereas the 'BluControl' is for the touch control.

4.1 AMR_Voice

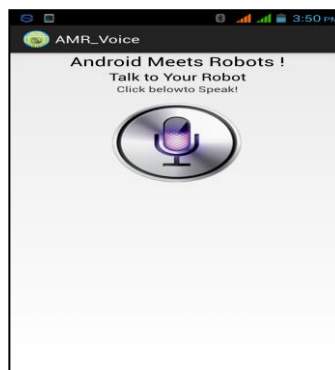

Figure 4.1 AMR_Voice

This is a voice -controlled application. As shown in the figure on tapping the microphone (mic) icon, the voice commands is sent for controlling various appliances.

First step is to tap the mic icon and say something. The speech commands get converted to text. The converted text is sent over the Bluetooth of the Android mobile to the serial buffer of Arduino via Bluetooth module HC-05. From the serial buffer data retrieved for the voice commands. By using Arduino Uno programmer the data strings are compared with look up table and generated an actuation signal for the relays to control various appliances.

Table1. Voice Commands for the Applications

S.No	Voice Command	Action Performed
1.	Pick	Catch the weight
2.	Release	Drop the weight
3.	Right	Move to right
4.	Left	Move to left
5.	Up	Move to forward
6.	Down	Move to backward

4.2 BluControl

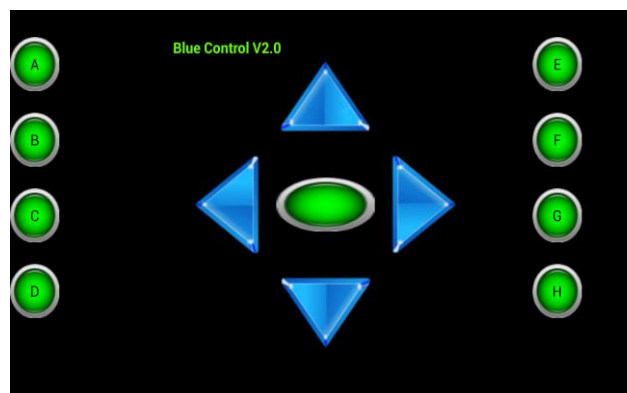

Figure 4.2 BluControl Application

It is another Android application that is also readily available on the GOOGLE Play store. It serves as a touch control application. As shown in Figure a total number of six(6) direction arrow are controlled using this application. It works on the similar principle as depicted above; the only difference is that on touching the control relays on the app, converts the action in to motor rotation. It is linked with Bluetooth of the Android mobile to the Arduino serial buffer via Bluetooth Module HC-05. After obtaining the various motor rotation, the system is so designed that the control strategy for each of the moving action may be actuated using the relays.

Table2. Touch Commands for the Applications

S.No	Touch Command	Action Performed
1.	Key D	Catch the weight
2.	Key H	Drop the weight
3.	Right arrow	Move to right
4.	Left arrow	Move to left
5.	Up arrow	Move to forward
6.	Down arrow	Move to backward

V WIRELESS HOIST CONTROL

The wireless hoist control system block diagram is shown in figure. The smart phone in build Bluetooth model are connected to Bluetooth HC-05.

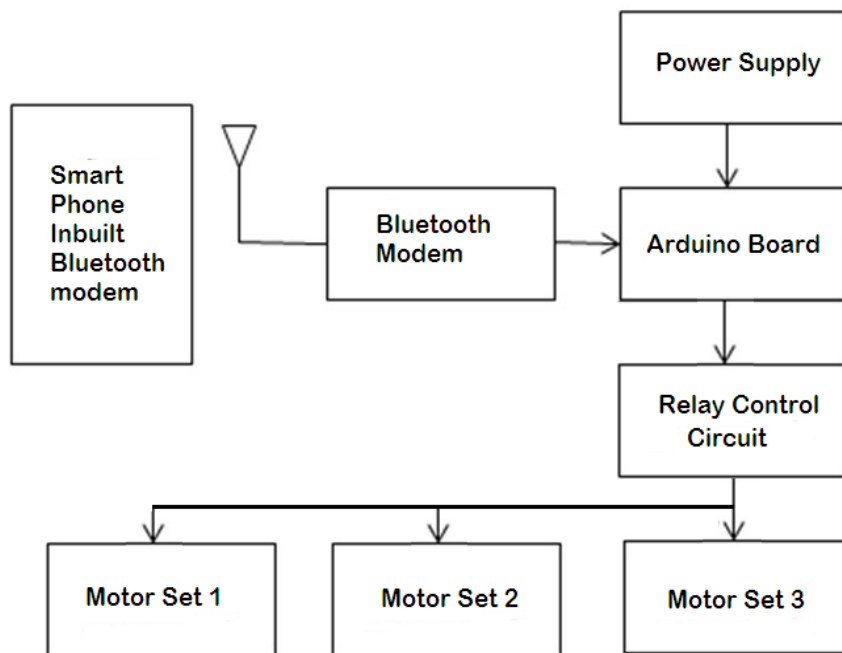

Fig.5.Block Diagram

5.1 AMR_Voice

For using the voice commands the following steps are as follows:-

Step1: Open the AMR_Voice application and click on the “Connect Robot” as shown in Figure 5.1.1 to connect the application to the Bluetooth module HC-05.

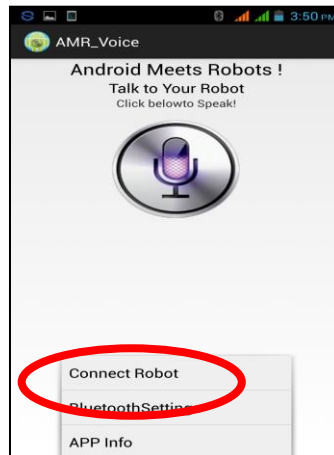

Figure5.1.1 Option to connect the app with HC-05

Step2: Once the module is connected tap on the mic icon of the app as shown in Figure 5.1.2 and say the command.

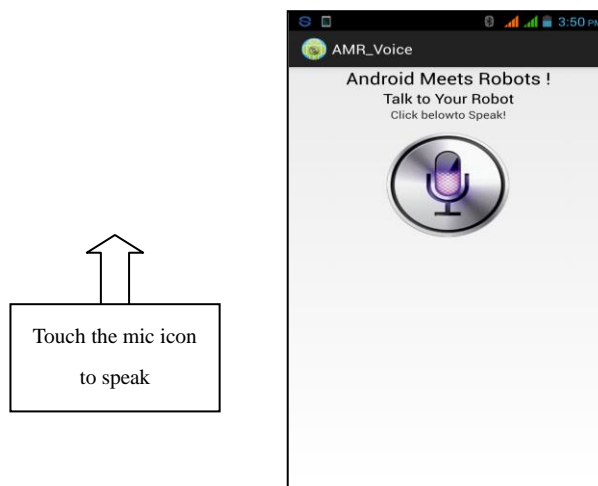

Figure 5.1.2 Touch the mic icon to speak

Step3: Once we speak the app converts the voice to text using Google voice services that go over the phone Bluetooth to the Bluetooth module HC-05.

Step4: From the serial buffer we get the stored text, and we use it as the control commands for various purposes.

5.2 BluControl

For using the BluControl for touch control the following steps follows:-

Step1: Open the BluControl Application and tap on the Connect button which will connect our application to the HC-05 as shown in Figure 5.2.

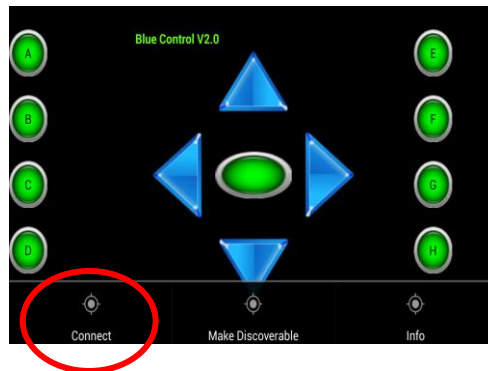

Figure 5.2 Tap Connect to make the connection with HC-05

Step2: Once the module is connected tap on the Arrow button for the various direction to operate the hoist.

5.3 Hoist Model

Below is the working prototype of the Wireless Hoist control system:



Figure 5.3.1 Hoist model front view



Figure 5.3.2 Hoist model side view

VI CONCLUSION

Bluetooth technology is interesting in industrial application, especially due to the flexibility, low cost and high-speed data transfer. An study of the Bluetooth application in an industrial environment has been presented in this work. The voice and touch control for the home automation system are implemented and has been tested successfully. While using the voice commands, care must be taken to have a noise free environment. The combination of Bluetooth Arduino and android has brought up a best way or a smart way to operate the hoist wireless from a remote location. It's main advantages is that it helps in hassle free operation of hoist and helps in keeping the work floor sheets free. This system has the scope for modifications, and more devices can be added

and further research can lead to a smarter control system. As a last concluding point is to say that Bluetooth network has the great potential to offer a smart wireless transmission industrial environmental and with the help of additional error correction scheme and studies in real time and fault occurred we can increase its applicability.

REFERENCES

- [1] Anup Kumar, Ranjeeta chauhan, Voice Controlled Robot,2014 *IJIRT, Volume 1 Issue 11, ISSN: 2349-6002*
- [2] Sushant Kumar, S.S Solanki, Voice and Touch Control Home Automation, *3rd Int'l Conf. on Recent Advances in Information Technology, RAIT-2016*
- [3] Sushabhan Choudhury, Piyush Kuchhal, Rajesh Singh, Anita, ZigBee and Bluetooth Network based Sensory Data Acquisition System, *ICCC-2014, Procedia Computer Science 48 (2015) 367 – 372*
- [4]https://play.google.com/store/apps/details?id=robotspace.simple_labs.amr_voice&hl=en
- [5] J. Smoczek, J. Szpytko, P.Hyla, The Application of an Intelligent Crane Control System, 13th IFAC Symposium on Control in Transportation Systems The International Federation of Automatic Control September 12-14, 2012. Sofia, Bulgaria
- [6]<https://www.arduino.cc/en/guide/introduction>
- [7]http://www.tec.reutlingen-university.de/uploads/media/datenblatthc-05_bt-modul.pdf
- [8]<https://www.arduino.cc/en/Tutorial/ArduinoISP>
- [9]https://en.wikipedia.org/wiki/google_voice_search
- [10]<https://www.arduino.cc/en/Reference/Libraries>
- [11]Bluetooth specification version 1.2,2003.
URL: <http://www.bluetooth.com>
- [12]J. Bray, C.F. Sturman, *BLUETOOTH: Connect without cables*, Prentice Hall, 2002.