

## “Wireless system for water flow monitoring”

Peeyush<sup>1</sup>, Ganesh Shankar<sup>2</sup>, Rudranna Nandihalli<sup>3</sup>

<sup>1</sup>M.Tech (Power Electronics, EEE), R.V College of Engineering, Bengaluru-56,(India)

<sup>2</sup>Managing Director, FluxGen Engineering Technologies Pvt. Ltd., Bengaluru-76,(India)

<sup>3</sup>Professor (EEE Department), R.V College of Engineering, Bengaluru-56,(India)

### ABSTRACT

Lack of access to water is the undecorated reality for millions worldwide, and a proportionally unfortunate that at most 2.7 billion people live without access to enough sanitation. This paper presents a pathway to monitor the usages of water wirelessly to escape its wastage or leakage. Wireless technique includes powering of ZigBee, microcontroller, digital water flow meter and charging of li-po battery from solar panel using buck converter and boost converter. During night, powering of the ZigBee, microcontroller and digital water flow meter is carried out by Li-po battery without any disturbance to monitor water flows continuously. This paper also presents the protection scheme for a Li-polymer battery from over charging and under discharging condition. The simulation is carried out TINA software. The result of simulation and testing show that the design proposed in this paper is feasible.

**Index terms:** Battery protection, Boost Converter, Buck converter, Digital water flow meter  
Wireless communication.

### I. INTRODUCTION

In recent years, universally people are increasingly concerned with avoiding the wastage of surface as well as ground water. Ground water is the key problem, especially cities that have to rely on their own ground water for the water provision. In order to reduce the uses and wastage of water there is need to continuously monitoring of water.

This is known fact that the availability and performances of the solar panel, li-polymer batteries and power electronics system has increased dramatically in the last few years, there is a new trend in using solar power as primary source of energy for off-grid, low-power loads.

The purpose of this paper is too aware the people in regard to important of water because water not only hit out at our pocket but also slows growth of nation. By continuously checking the usage of water, wastage of water is minimized.

The buck converter or step down converter has input voltage more than output voltage. Input to buck converter is high variable voltage from solar panel and supply low constant voltage with low load regulation and high efficiency to charge batteries and simultaneously power the ZigBee, microcontroller and digital water flow meter. The boost converter or step up converter has input voltage less than output voltages. As the solar is out off application during night, li-po battery appears in application to power up microcontroller, ZigBee and digital water flow meter with the help of boost converter.

The boost converter or step up converter has input voltage less than output voltages. A lithium polymer battery, is a rechargeable battery of lithium-polymer innovation in a pocket shape, this makes them lighter additionally more inflexible. The exercise of discharging and over charging of li-polymer batteries is needed to be avoided by battery protection circuits. Digital water flow meter is a device use to measure the volume of water used in any commercial building or any institute. Microcontroller (MSP430) and ZigBee modules are use for communication with the server.

## II. BLOCK AND SCHEMATIC DIAGRAM

The block diagram of Solar based wireless network for water flow monitoring system as shown in Fig 2.1 and schematic diagram is shown in Fig 2.2.

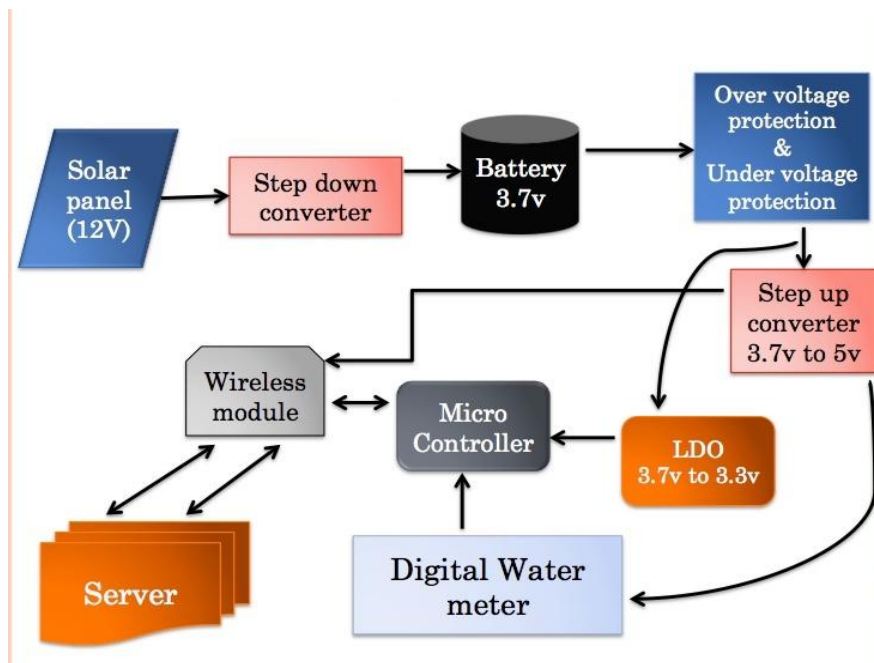

Fig 2.1 Block diagram

- LM2596 is buck converter, takes input from solar panel and gives output of 5V to charge the battery. Diode D2 is connected to between buck output and battery to avoid reverse current flow during night.
- DW01 is connected to protect the battery from over voltage and under voltage condition. Battery voltage is continuously been monitored; during over charge condition IC will trigger gate pulse to turn off MOSFET (M1), similarly during under-discharge condition IC will trigger to turn off MOSFET (M2).
- LM2731 is boost converter, that's step-up 3.7V from battery to two 5V output. One 5V pin is to power ZigBee module for wireless communication and other 5V pin is to power digital water flow meter. TLV1117LV is low dropout regulator (LDO). This IC gives regulated 3.3V output to power microcontroller.
- MSP430 is low energy consuming microcontroller to measure pulse from water flow meter and communicate with ZigBee. ZigBee modules is use in order to receive data from microcontroller and send the data to server.

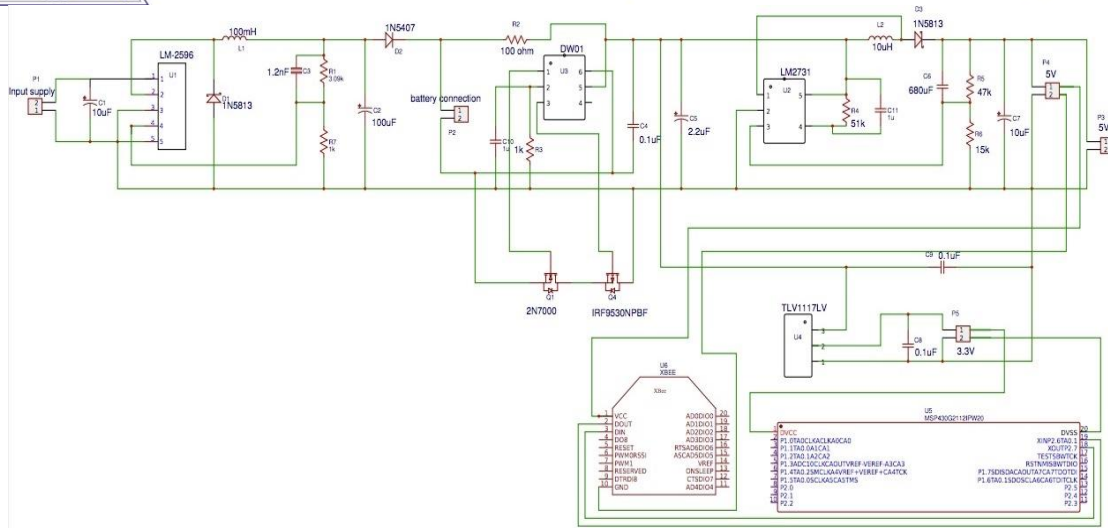

Fig 2.2 Schematic diagram

### III. BUCK CONVERTER

The Buck controller is a kind of switch mode control supply circuit that converts high voltage to low voltage. Say, +12 volts to +5 volts. The mix of the inductor and capacitor frames an LC channel smoothing out any swell made by the exchanging activity of the transistor. LM2596 is one of the most used in IC as shown in Fig 3.1. That have low voltage regulation, up to 3-A output load current, Input voltage range up to 40V, high efficiency up to 80%, thermal shutdown and current-Limit protection are features of LM2596. For buck converter input is variable high voltage from solar panel and supply constant low voltage at output terminal. Fig 3.2 represents waveform of output voltage, switch voltage and inductor current with 12V DC input voltage from solar panel during its peak period. Buck converter designed in this chapter is with good efficiency and minimum losses. Fig 3.3 represents efficiency waveform with change in load currents and Fig 3.4 represents waveform of ripple in output voltage with respect to load.

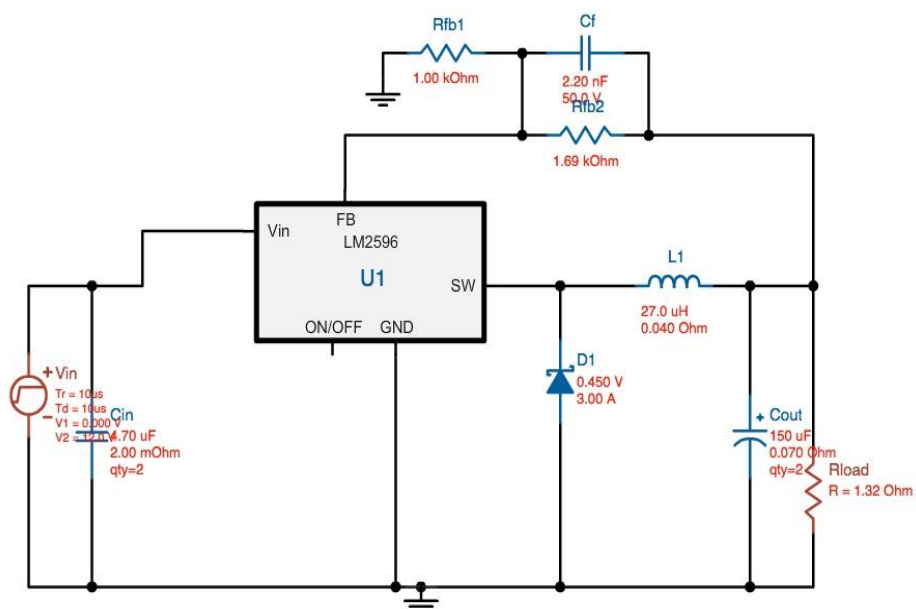

Fig 3.1 LM2596 Buck Converter

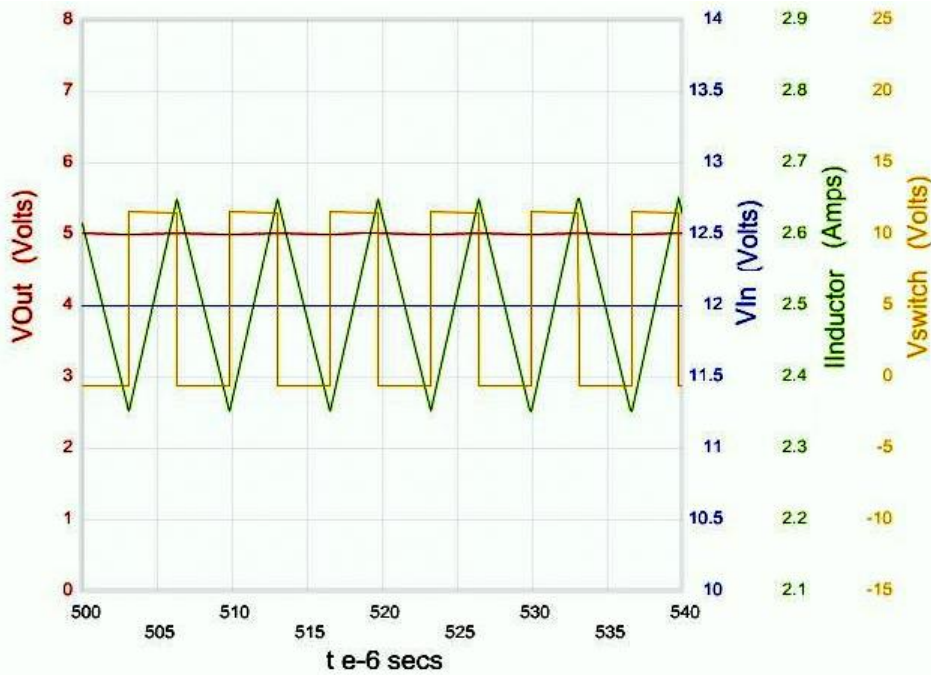

Fig 3.2 represents output waveform for 12V input voltage

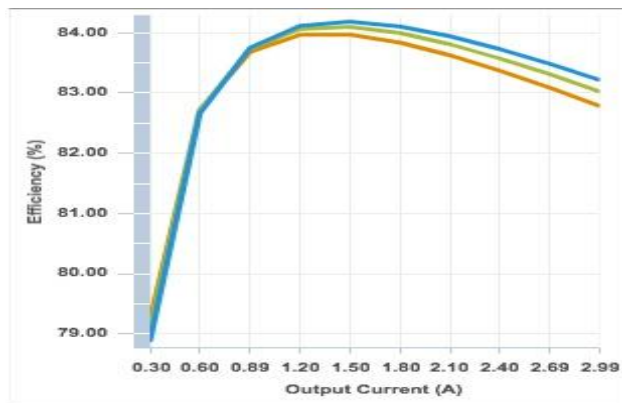

Fig 3.3 Efficiency variation with respect to load current

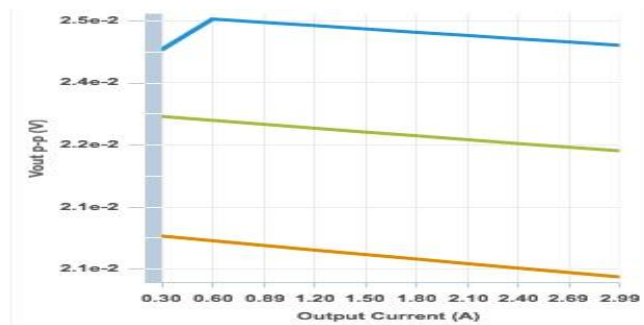

Fig 3.4 Ripples in output voltage with respect to loadcurrent

■ Vin=6V     
 ■ Vin=12V     
 ■ Vin=18V

### IV. BOOST CONVERTER

The boost converter is a high-efficiency step-up DC/DC switching converter. The converter uses a MOSFET as switch, the supply voltage energy is stores in inductors and then that energy is transferred into load. The LM2731 device is a switching converter IC that operates at a fixed frequency (0.6 or 1.6 MHz) for fast transient response over a wide input voltage range and incorporates pulse-by-pulse current limiting protection as shown in Fig 4.1. LM2731 is boosting converter IC with current up to 1.8A, wide input voltage range (2.7 V to 14 V), having efficiency more than 90%. Fig 4.2 represents the output voltage, switch voltage and inductor current with 3.7V DC that is its rating value. Boost converter designed in this report is with high efficiency and minimum losses. Fig 4.3 represents efficiency waveform with change in load currents and Fig 4.4 represents waveform of ripple in output voltage with respect to load.

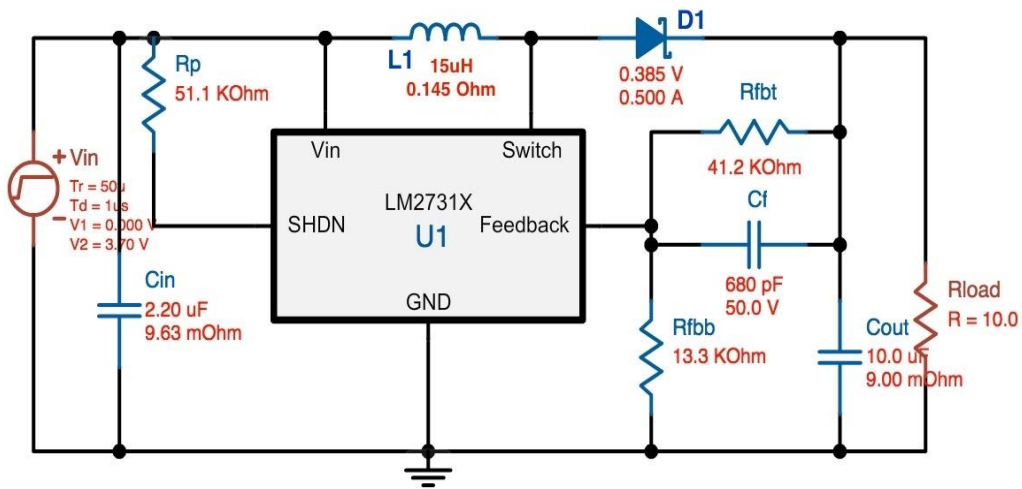

Fig 4.1 LM2731 boost converter

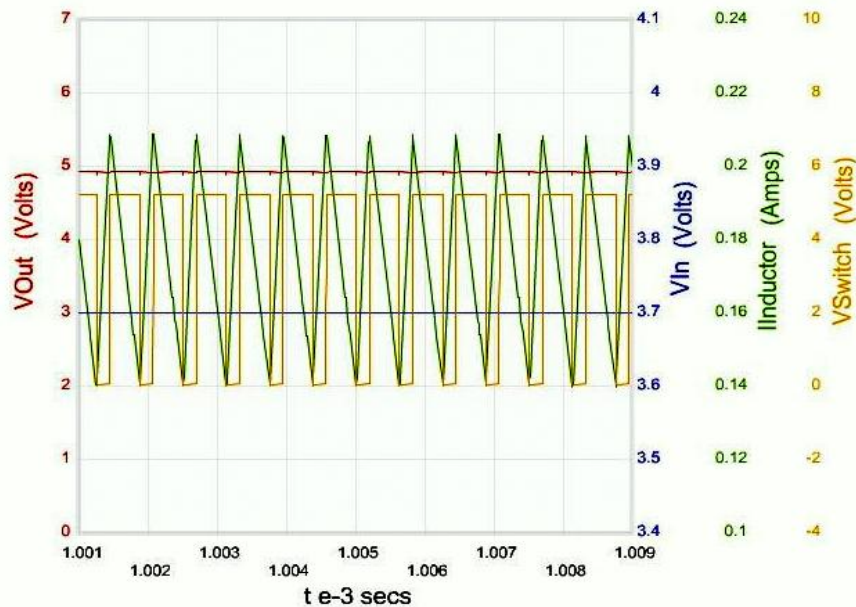
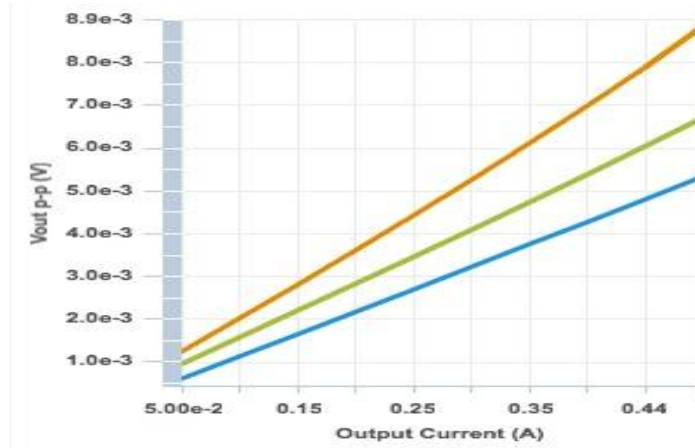
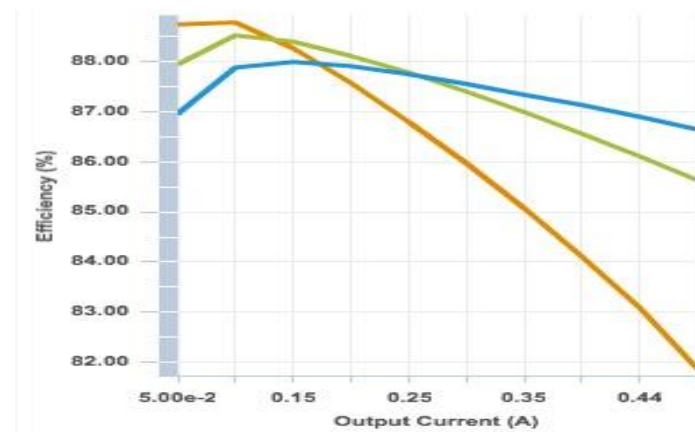

Fig 4.2 represents output waveform for 3.7V DC input voltage

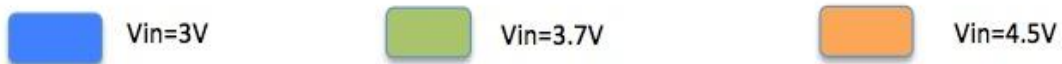



**Fig 4.3 Efficiency variation with respect to load current**

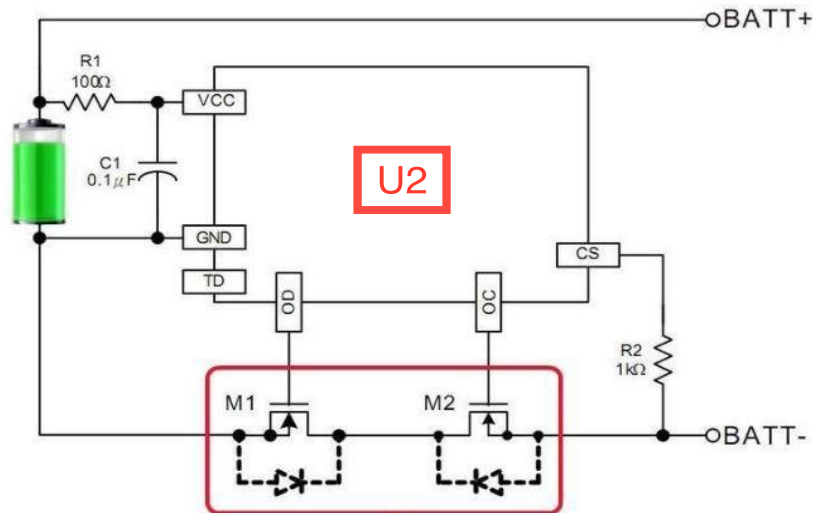

**Fig 4.4Ripplesin output voltage with respect to load current.**



### V. BATTERY PROTECTION CIRCUIT

Lithium-polymer batteries are too delicate in regards in overcharging and over discharging common design practices are implemented to protect the battery. The DW01 integrated circuit is a battery protection integrated circuit with overcharge, over discharge, and overcurrent protection for single-cell lithium-polymer batteries. The battery voltage and current sensor pins are monitored through the use of operational amplifiers before entering the control circuit. If the battery voltage exceeds a preset voltage of about 4.2 volts, then the overcharge protection kicks in, removing the voltage from the overcharge (OC) pin, disconnecting the battery from the charger. If the battery voltage drops below about 2.5 volts, the over discharge protection is activated and disconnects the battery from the circuit via removing the voltage that is driving the over discharge (OD) pin. The overcurrent protection works by continuously monitoring the battery voltage through a sensing resistor (R2) and connecting to a current sensing (CS) pin. If the current sensing pin exceeds the protection voltage, over discharge pin is then driven low, disconnecting the battery from the circuit.



**Fig 5.1 Battery protection IC-DW01**

**VI. LDO (Low Drop-out Regulator)**

TLV1117LV is a greatly low-control expanding gadget that takes 500 times bring down quiescent current than conventional voltage controllers. At the start of every cycle, the comparator of IC- TLV1117LV measures the voltage using voltage divider connection as shown in Fig 6.1. If the voltage is more than the maximum rating (6V) the logic circuit will drive the comparator to make IC thermal shut down to provide over voltage protection by making the MOSFET switch off. Whenever the supply voltage is well within the range (6V-3.3V) the output will be fixed value of 3.3V. As the supply voltage is less than 3.3V (min 2.5V) the output will follow the input with voltage drop less than 0.1V (only drop because of Rds ).

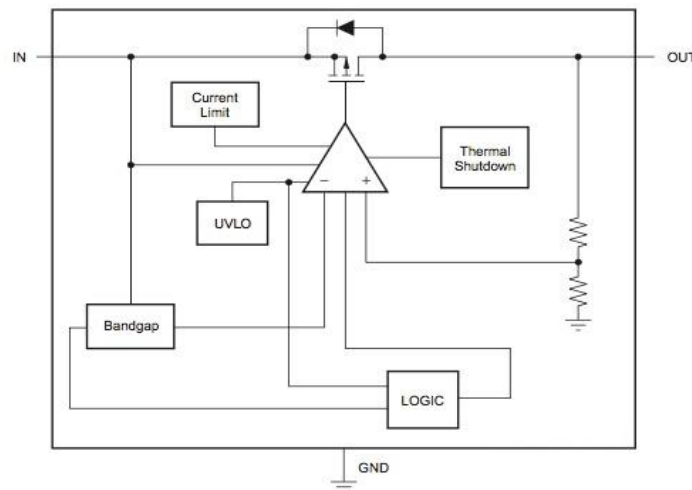

**Fig 6.1 Functional block diagram of TLV1117LV**

**VII. HARDWARE CONFIGURATION AND RESULTS**

The hardware implementation component for solar-based wireless system is shown in Fig 7.1. The various components comprises of solar panel, digital water flow meter, Lithium polymer battery, DC/DC step-up and

step-down converter with battery protection circuits, ZigBee modules with antenna and microcontroller as shown in Fig 7.1 and Fig 7.2.

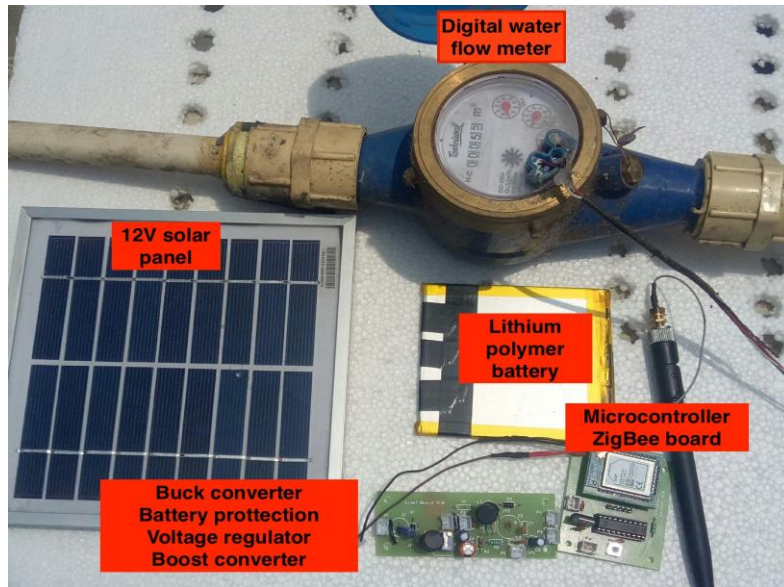

Fig 7.1 Complete hardware component



Fig 7.2 Hardware of converters, microcontroller and ZigBee

**A. Efficiency of converter:** The converter efficiency is computed by various parameter measurements such as input and output voltage and current. It is calculated that full load efficiency of buck converter is 80% and that of boost converter is 90%.

**B. Load regulation:** is the measurement of the ability of a converter to maintain, constant output voltage despite changes in load. A good load regulation implies that the power supply will deliver a



stable voltage to the system. Load regulation of buck and boost converter is tabulated in Table 7.1 and absorbed that load regulation of buck converter is 2.04% and boost converter is 1.2%.

**Table 7.1 Load regulation of converter**

	Buck converter	Boost converter
<b>Voltage at no load</b>	5.01V	5.00
<b>Voltage at full load</b>	4.90V	4.94
<b>Load regulation</b>	2.04%	1.2%

**C. Battery protection waveform:** battery protection is vital to improve battery life and its functioning. If the battery is operated under under voltage condition, more than specified numeral of cycle then battery may get damage. It is observed in Fig 7.3 that as the battery terminal voltage becomes lower than 2.53V, the battery protection circuit disconnects the battery connection to load.

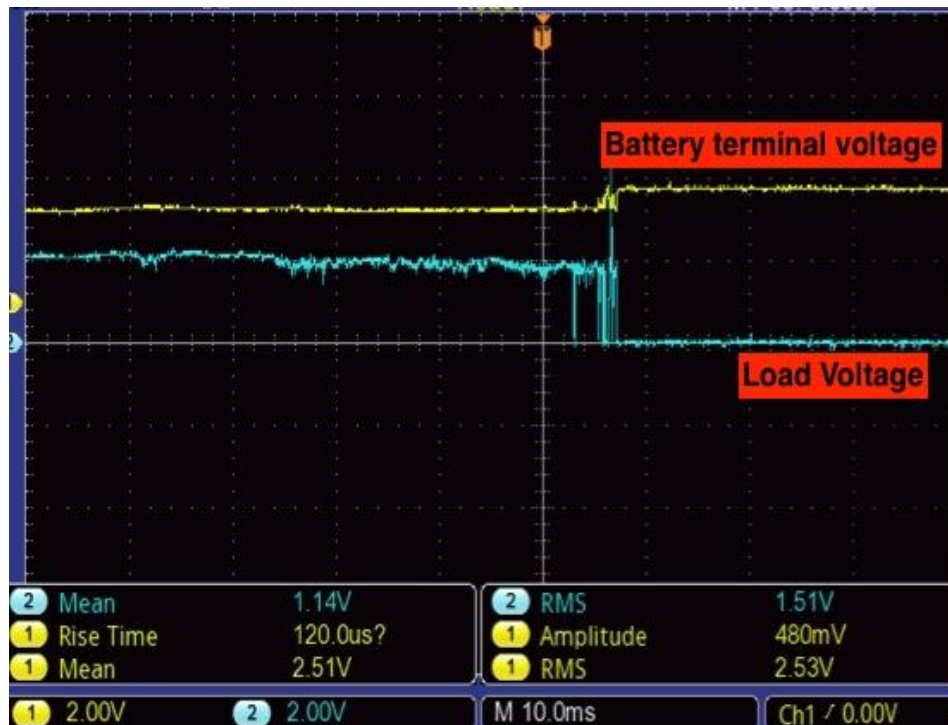

**Fig 7.3 Battery protection waveform**

**D. Ripple in output voltage:** CRO is a digital measurement instrument to observe various waveforms. Ripple in output voltage at 5V and 1A load and it is found that the ripple is well within limit and is 100mV. Ripple Voltage at 5V and 0.5A load condition is observed as 50mV is observed in Fig 7.4 and Fig 7.5. Ch1 (yellow): shows switch voltage of LM2731 and Ch2 (blue): shows the ripples voltage in the output.

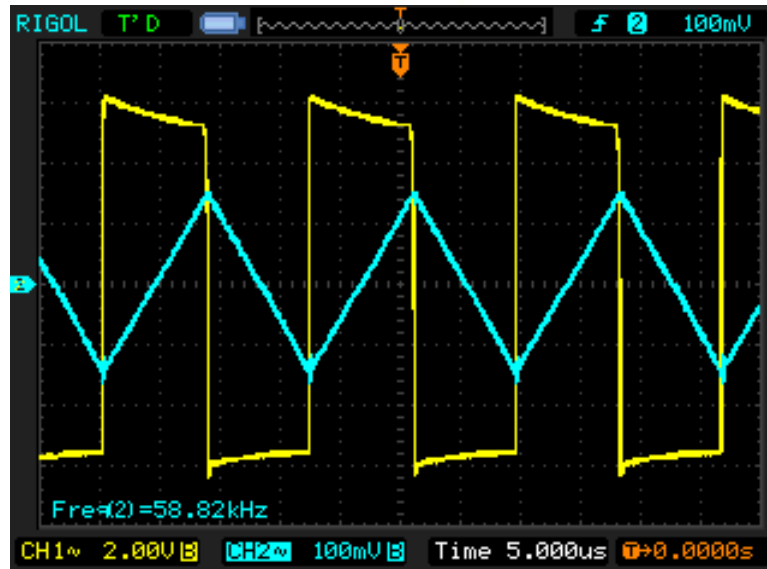

Fig 7.4 Ripple at 5V,1A

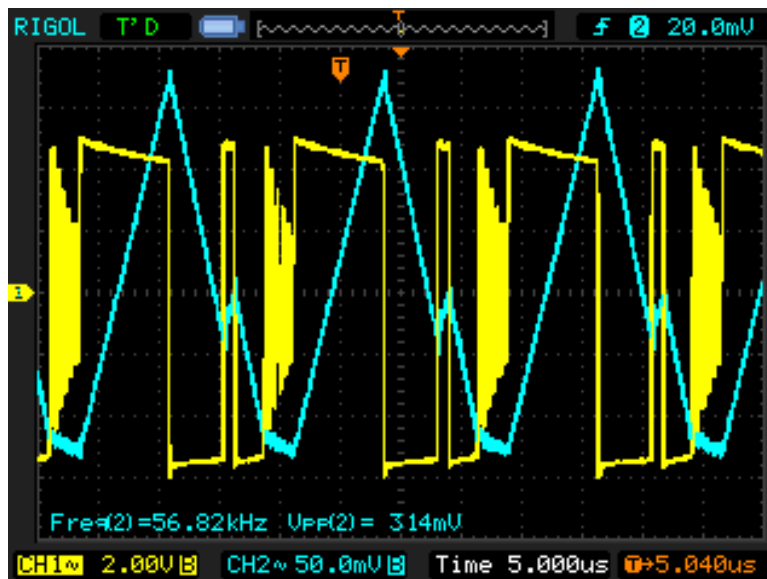

Fig 7.5 Ripple at 5V,0.5A

## VIII. CONCLUSION

Solar based wireless system for water flow monitoring was designed and implemented successfully. Output of solar panel varies with sunlight intensity, this variable input was converted into constant voltage  $5V \pm 3\%$  by buck converter to charge the battery completely. The efficiency of the buck converter is found 80% at full load.

The battery protection circuit is also provided to improve the battery life. It is observed that the protection circuit disconnects the load as battery voltage falls below 2.53V or rises above 4.2V. The battery voltage 3.7V is stepped up to  $5V \pm 3\%$  with the help of LM2731 boost converter. The efficiency of boost converter is found 90% at full load. Communication between wireless modules is successfully implemented. Output pulses of digital water flow meter is calibrated and transmitted to server via ZigBee module.



## REFERENCES

- [1] S. R. Shaikh and Prof A. M. Jain, "A literature survey of Photovoltaic Water Pumping System", IEEE International Conference on Control, Instrumentation, Communication and Computational Technologies (ICCICCT), Kumaracoil, India, pp 511-516, 18-19 Dec. 2015.
- [2] Ke Liu and John Makaran, "Design of a Solar Powered Battery Charger", IEEE Electrical Power & Energy Conference (EPEC), Montreal, QC, Canada, pp 264-268, 4th March-2010.
- [3] Prasad. M. Pujar, Harish. H. Kenchannavar and U. P. Kulkarni, "Wireless Sensor Network Based Water Monitoring Systems: A Survey", IEEE Applied and Theoretical Computing and Communication Technology (iCATccT), Bangalore, India, pp 155-159, 22nd July-2016.
- [4] Yin-HaiZhang, Ji-Gang Li, Jun Lin and Jin-FaGe, "A Charging Equalization Circuit with Odd and Even Module for Li-ion Series-connected Batteries", IEEE Artificial Intelligence and Computational Intelligence, Shanghai, China, pp 553 – 557, 12 January 2010.
- [5] ShabanaSheth and Mohammad Shahidehpour, "Tidal Energy in Electric Power Systems", IEEE Power Engineering Society General Meeting, San Francisco, CA, USA, pp 630 – 635, 01 August 2005.
- [6] Taesic Kim, Wei Qiao and LiyanQu, "Self-Reconfigurable Multicell Batteries", IEEE Energy Conversion Congress and Exposition (ECCE), Phoenix, AZ, USA, pp 3549-3555, 01 November 2011.
- [7] Santosh G. Kashid, Sanjay A. Pardeshi, Sushil D. Sirsat and Vijaysinh H. Bonge, "Remote Cap ring of Water Meter Reading Using DSP Processor", IEEE Image Information Processing (ICIIP), Wanknaghat, India, pp 45-49, 25th Feb-2016. WANG Yeqin, HAN Zhigang and SHI Jianghua, "One Cell Lithium-ion Battery Protection IC", IEEE Industrial Electronics and Applications (ICIEA), Hangzhou, China, pp 1427-1432, 23rd Oct- 2014.