

# HERTZIAN CONTACT ANALYSIS OF SPUR GEAR

**Akash Deep**

*Mechanical Engineering Department, GLBITM, Gr. Noida, India*

## **ABSTRACT**

*Present research work is conducted for the better performance of the gear. A reliable gear system must withstand the stresses induced during the mesh. Present research work includes the comparison of stress concentration factor and field of failure with change in module with same number of teeth with different diameter and then comparing the result with theoretical Hertzian Contact equation. The theoretical contact stress calculation is done by Hertzian Contact Equation. To continue with our project we first created a 3D model of a spur gear in Pro-E. Their performance behavior is then studied in ANSYS assuming the change in module and diameter of meshing gear which was the platform of our research work. The analysis is repeated with different module and diameter of spur gear to achieve the most accurate result.*

**Keywords:** *Ansys, Contact Stress, Gear, Hertzian Contact Equation, Module.*

## **I INTRODUCTION**

Gear is a mechanical device which is used to transmit torque and motion. Gears as we know are used to transmit torque and motion. Gears have become the major research area now a day. The reasons why gears are used to this day can be best described by the following facts Gears range in size from small instrument installation, such as watches to large, powerful gears used in large turbine drive for ocean liners. Gears offer positive transmission power. Transmission accuracy can be freely controlled with high accuracy by changing the number of gear teeth. Gears can couple power and motion between shafts whose axis are parallel intersecting or skew.

Gears can be of different types such as Parallel axes gears, Intersecting axes gears, non-parallel axes gears and non-intersecting axes gears. Our project is based on Spur gear which comes under the category of Parallel axes gears. This is a cylindrical shaped gear, in which the teeth are parallel to the axis. It is the most commonly used gear with a wide range of application and is the easiest to manufacture. Hertz analyzed contact stresses at two different elastic gear and assumed small strain within elastic limit. The different modes of failure of gear teeth are bending failure, pitting failure and scoring generally. Pitting failure which is the surface fatigue failure occurs due to the repetition of Hertz contact stress. This failure generally occurs when the surface contact stress are higher than the endurance limit of the material. Hertzian contact stress refers to the localized stress that develops as two curved surfaces which come in contact and deform slightly under the imposed loads. The deformation that takes place depends upon the modules

of elasticity of the material in contact. These contact stress are actually cyclic in nature and overtime it leads to sub-surface fatigue cracks in the gear.

It is very important to determine the performance of the gear beside the material and the mode of manufacturing. The performance parameter depends on the failure of the gear like tooth bending, surface distress and tooth deflection. A research work was done on a computational modal of a gear which helps in determine the life of gear teeth flank with respect to the surface pitting. Through a certain period of time contacting surface of surface curvature can also be estimated in this research work [1].The geometrical location of high point for single tooth contact form the basic gear geometry and has compared the bending fatigue behavior of teeth by loading them from high point of single tooth contact. It proved to be the simplest and quickest way for evaluating the performance of gear produced by the various methods of production [2].The main motive of this research work was to study the stresses and transmission error of gear in mesh as this is one major factor on noise and vibration produced in gear set. The theoretical value was being calculated with the help of Hertzian equation while an analytical model was made in ANSYS and an analysis was done over the same and after the analysis both the results we compared with one another [3].The motive of this work is to analyze the contact stress between the two spur gear teeth with the variation in the contact position. A program was developed to plot a pair of teeth in contact. For every 3<sup>0</sup>pinion was being rotated and hence first and last location of contact was being calculated. This program was being done over number of times for example like 10 times. For each program finite element models were made and a analysis was done [4]. In this research work he tried to introduce many different holes in the gear in order to reduce the stress concentration. For this work three teeth segments of a spur gear was used along with various holes in the gear too [5].This work was done to find the maximum contact stress in gear teeth in the stress analysis for mating the teeth in ANSYS. The result which was analyzed from the analysis was compared with the theoretical value which was obtained by Hertzian contact equation. Material that was used in this project was grey cast iron and steel for comparison and a general result was obtained [6].

## II METHODOLOGY

The important parameters in design of spur gear are module, number of teeth, face width, pitch circle diameter. In the present study we are focusing on the contact stress between the two mating gears. For analysis of stress we use the ANSYS and Pro-E. In pro-e we made the spur gear and its assembly then this assembly is import in ANSYS for the analysis of stresses, strain and stress probe. After this the result will be compared with the theoretical result obtained from Hertzian equation.

### 2.1 Material selection

Material taken for the spur gear is “mild steel”. The different properties of mild steel are given in the table 1.

## 2.2 Modeling of spur gear

Modeling of spur gear is done in Pro-E. The different parameters used during modeling are given in table 2.

**Table 1 Properties of Mild Steel**

S.No	Material Property	Value	Unit
1	Density	7860	Kg/m <sup>3</sup>
2	Young modulus of elasticity	210000	MPa
3	Tensile Strength	410	MPa
4	Compressive Strength	407.7	MPa
5	Poisons Ratio	0.303	-

**Table 2 Modeling of Gear**

S.No	Dimension	Symbol	Value	Unit
1	No. of teeth	Z	20	-
2	Pitch Circle Diameter	D	60	Mm
3	Pressure Angle	$\phi$	20	Degree
4	Addendum Radius	R <sub>A</sub>	66	Mm
5	Dedendum Radius	R <sub>D</sub>	53.058	Mm
6	Face Width	B	40	Mm
7	Shaft Radius	R <sub>S</sub>	12.5	Mm

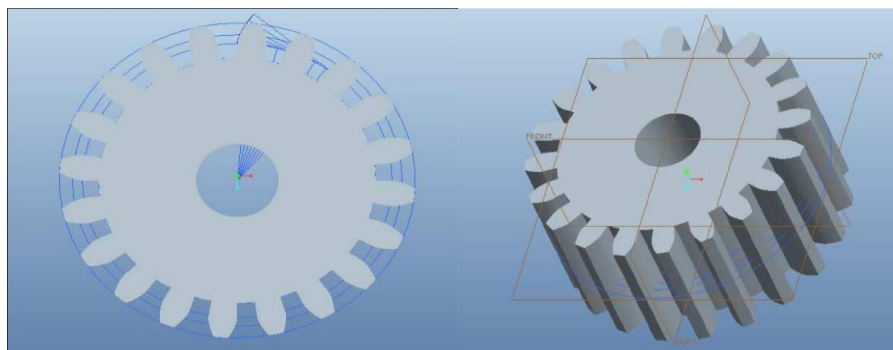

**Fig.1 Modelling of Spur Gear**

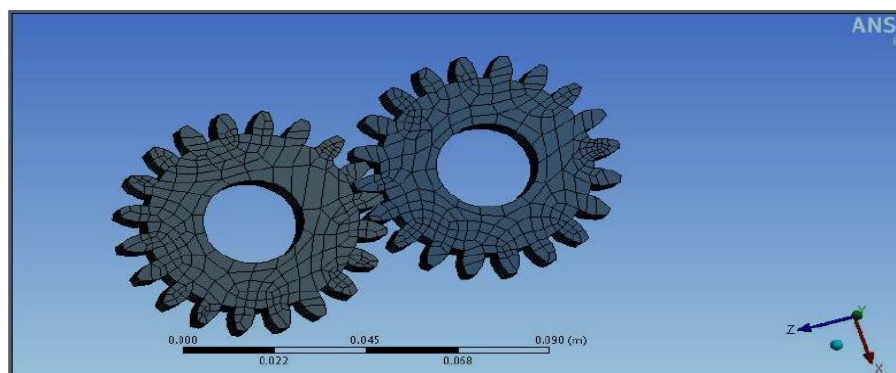

**Fig.2 Meshing of spur gear with module 3**

### III RESULTS

After the analysis of spur gear having module 3 done in ANSYS after the file being imported from Pro-E various results were produced like maximum elastic strain and minimum elastic strain along with the maximum and minimum stresses and stress probe. The values for maximum strain were  $2.779e-004$  m/m while for minimum elastic strain was  $1.3031e-010$  m/m. The Maximum equivalent stress was  $4.8808e+007$  Pa and minimum equivalent stress was  $27.365$  Pa and finally maximum stress probe was  $1.7948e+005$  Pa and minimum stress probe was  $1.7948e+005$  Pa.

Comparison was done between the module and contact stress. From the above analysis we came to the conclusion that by increasing module the contacts stress decreases. It is clearly observed from the graph, that the variation of the contact stress with module is more in case of ANSYS i.e. the value decreases rapidly with the increase in module. While in case of Hertzian Contact Equation the variation is low as compared to ANSYS. The common thing came from the graph that on increasing module contact stress decreases. The results are in accordance with Zeping Wei [3].

**Table 3 Comparisons of gear with different module**

S.No	Module	Contact Stress(MPa)
1	3	48.808
2	4	23.157
3	5	10.032

**Table 4 Comparisons of gear with different module**

S.No	Module	Contact Stress(MPa)
1	3	463.895
2	4	401.745
3	5	359.332

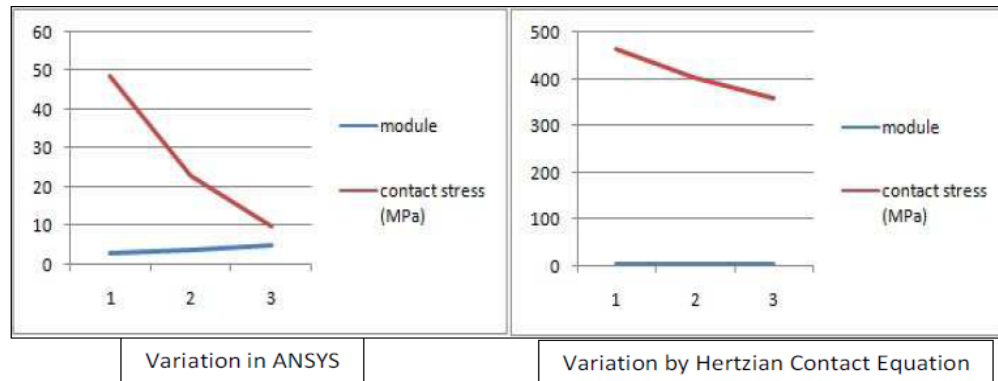

Figure 3. Comparisons of different module and contact stresses

#### IV CONCLUSIONS

After the analysis done in ANSYS we have seen that on increasing the module the contact stresses have been reduced along with the Hertzian equation evaluation the contact stresses were much higher as compared to the contact stresses developed in ANSYS. When module having value 3 was taken we have seen that 87% less contact stresses were developed in comparison to the value of module 4 we have seen that almost 90% of less contact stresses were generated in the spur gear. Hence we can say that on increasing the module in ANSYS the contact stresses were less generated.

#### REFERENCES

- 1 Goldez S., Sraml M., Kramberger J, A Computational model for determination of service life of gears ,Int. J. Fatigue, 25 Feb 2002.
2. Akata E., Altmbalik M.T., Can Y ,Three Point Load Application in Single Tooth Bending Fatigue Test forevaluation of Gear Blank Manufacturing Methods , *Int. J. Fatigue*, 26, 2004.
3. Zeping Wei, Stress and Deflection in Involute Spur Gear by Finite Element Method , M.Sc. Thesis, University of Saskatchewan, 2004.
4. Ali Raad Hassan, Contact Stress Analysis of Spur Gear Teeth Pair , *World Acad. Sci., Eng Technol.*, 34, 20 Oct. 2009.
5. Vamsi M.V., Bhargav S., Sriram A, Spur Gear Tooth Stress Analysis and Stress Reduction, Project Report , *GokarajuRangaraju Inst. Eng. Technol.*, 2013.
6. Vivek Karaveer, Ashish Mogrekar, T. Preman Reynold Joseph, Modelling and Finite Element Analysis of Spur Gear , *Int. J. Current Eng. Technol.*, 3(5), Dec 2013.