

## **HIGH FREQUENCY SWITCHING OF MULTI SEGMENT PSEUDO RESONANT BOOST CONVERTER FOR ELECTRIC DRIVES**

**S. Vinod Kumar<sup>1</sup>, Dr.S. Sujitha<sup>2</sup>**

*<sup>1,2</sup> Assistant professor, Department of Electrical & Electronics Engineering,  
New Horizon College of Engineering, Bengaluru*

### **ABSTRACT**

Renewable energy sources, such as offshore wind farms, require high voltage gains in order to interface with power transmission networks. Previously, these conversions are normally made using bulky, complex, and costly transformers and high-voltage ac-dc converters with unnecessary bidirectional power flow capability. In order to avoid the use of huge transformers with large turns ratio, multiple modules of single-switch single-inductor dc-dc converters was proposed. It can reach high gains without transformers in these applications due to low semiconductor conduction loss in high-power devices. To overcome this, a new approach for high-gain high-voltage dc-dc converters using soft switched quasi resonant boost converters is proposed. This approach reduces the switching losses associated with the semiconductor devices and increases the reliability during transmission.

### **I. INTRODUCTION**

Research in harnessing and delivering electrical power from renewable energy sources (RES), has sky rocketed as political and economic concerns have threatened traditional fossil fuel supplies. Especially more than 100 GW of capacity has been installed throughout the world. Recent research has investigated grid connections monitoring to increase reliability.

Locations that are well suited for large scale wind energy production, such as offshore wind farms, are often far from demand centers. Efficient transmission of the generated power over these long distances requires boosting turbine voltages to high voltage. High voltage DC transmission appears promising for offshore wind farms, but it requires power electronic converters to boost and control wind turbine outputs.

The conventional methods used for boosting has many disadvantages like use of many components, large transformers and switching losses. The soft switched multi module quasi resonant converter technique is proposed, which overcomes the above disadvantages. This ultimately leads to the increased reliability and efficiency in the transmission system. Thus high gain is achieved.

### **II. CONVENTIONAL METHODS**

#### **A. Conventional HVDC method**

The conventional HVDC approach connects the wind turbine output to the ac line-frequency transformer with a large turns-ratio and two secondaries (Y and  $\Delta$ ) for voltage boosting. It is

then connected to the 12 pulse thyristor bridge for rectification and power flow control. The rectified output is connected to the load. This technology is robust and reliable. But it has many disadvantages. The fig 1 shows the circuit diagram of Conventional HVDC converter.

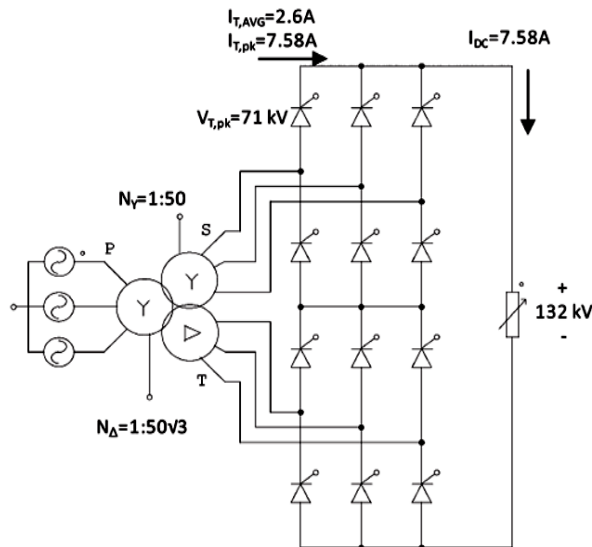

**Fig 1. A Conventional HVDC Converter**

The maximum output voltage of the SCR bridge is 1.35 times the input line voltage, so each transformer must provide a gain of 50 for a total gain of 135. Each SCR bridge sees half the input voltage, so SCRs must be rated for one half of the input sinusoidal peak voltage. The SCR bridges are controlled to produce 132 kV.

Disadvantages of this method are:

- It requires bulky, complex, and costly line-frequency transformers at each end of the conversion (rectification and inversion).
- The inherent bidirectional power flow capability is of less importance at the offshore wind farm side.
- High-frequency pulse transformers with large turns ratios are difficult to design at high voltage and power levels.
- Problems include poor coupling, dielectric losses in insulation, and core losses from non sinusoidal excitation.
- The distributed capacitance of the winding turns can lower efficiency and slow the pulse transitions.

### **B. Full bridge converter**

The full-bridge converter method has an six pulse bridge rectifier and an isolating transformer with high turns ratio. The wind turbine output is given to six-pulse bridge rectifier for rectification. The rectified output is then connected to the isolating transformer. The isolated output is connected to the load. The isolation level required for this method is 1.35 kV. The fig 2 shows the circuit diagram of Theoretical Full-bridge converter.

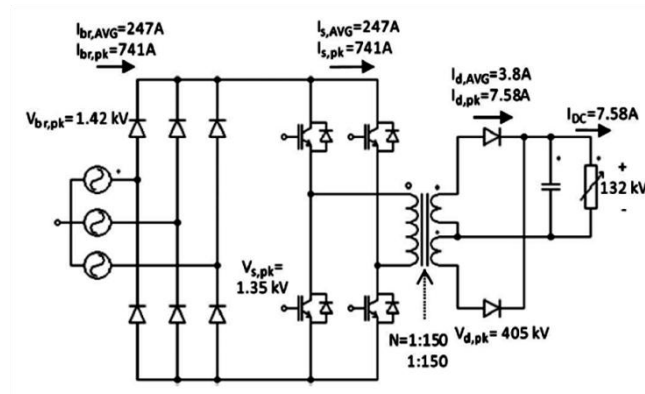

Fig 2. Theoretical full bridge converter

Disadvantages of this method are:

- High-frequency pulse transformers with large turns-ratio are difficult to design in high-voltage high-power applications.
- Since the switch valves withstand only the rectifier output, the diode valves must withstand the reflected rectifier output voltage.

### C. Multiple module Series hybrid converter

The series-hybrid converter uses an ac transformer to improve the gain and is connected to the rectifier. The rectified output is given to the multiple modules of series converters. The voltage gets boosted in these converters. Each converter operates from equal input voltages and draws equal input currents. It is then connected to the load. The fig 3 shows the circuit diagram of Multiple-module series-hybrid converter. Because of the lower gain of this converter, an ac transformer with a 4×turns ratio is added before the rectifier.

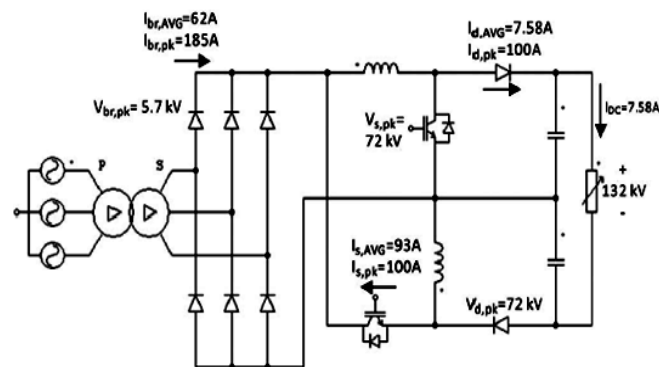

Fig 3. Multiple module series hybrid converter

Disadvantages of this method are:

- It again requires a bulky transformers of high turns ratio.
- It has multiple series semiconductor drops.

#### D. Multiple module cascade boost converter

In this system, the wind turbine output is given to the diode bridge rectifier. The output is rectified and is given to the first boost converter. The voltage is boosted and is given to the next boost converter. The voltage gets boosted to 100 times by the cascaded boost converters. Each boost converter is designed to provide a gain of 9.9 at a duty cycle of 0.899.

The switch and diode valve voltage stresses in a boost converter are equal to the output voltage of each stage, and the average diode valve current equals the output current of each stage. The average switch valve currents are equal to  $D$  times the stage input currents. The peak values of both switch and diode valve currents are determined by the inductor current. The maximum isolation voltage is given by the valves in the output converter (132 kV). This boosted voltage is then connected to the load.

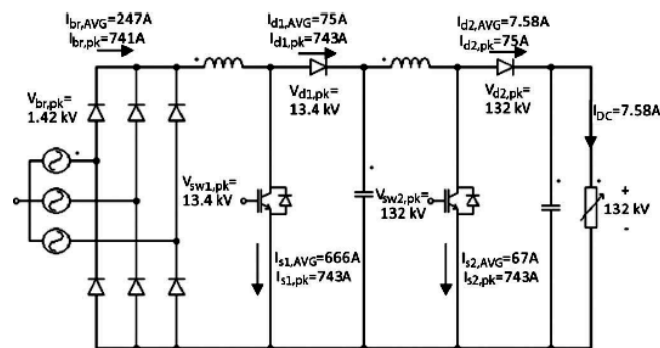

Fig 4. Multiple-module Cascade-boost Converter

Disadvantage of this method is:

- The switching losses are high.

### III. QUASI RESONANT CONVERTERS

Prior to the availability of fully controllable power switches, thyristors was the major power devices used in power electronic circuits. Each thyristor requires a commutation circuit, which usually consists of an LC resonant circuit, for forcing the current to zero in the turn-off process. This mechanism is in fact a type of zero-current turn-off process. With recent advancements in semiconductor technology, the voltage and current handling capability and the switching speed of fully controllable switches have improved significantly.

In many high-power applications, controllable switches such as GTOs and IGBTs have replaced thyristors. A resonant switch is a sub circuit composed of a semiconductor switch  $S$  and resonant elements  $L_r$  and  $C_r$ . Switch  $S$  can be implemented by a unidirectional or bidirectional switch, which determines the operation mode of the resonant switch.

#### A. ZC Resonant switch

In a ZC resonant switch, an inductor  $L_r$  is connected in series with a power switch  $S$  in order to achieve ZCS. If the switch  $S$  is a unidirectional switch, the switch current is allowed to resonate in the positive half-cycle only. The resonant switch is said to operate in half-wave mode. The fig 5 shows the two types of ZC resonant switch. If a diode is connected in anti parallel with the unidirectional switch, the switch current can flow in both directions. In this case, the resonant switch can operate in full-wave mode.

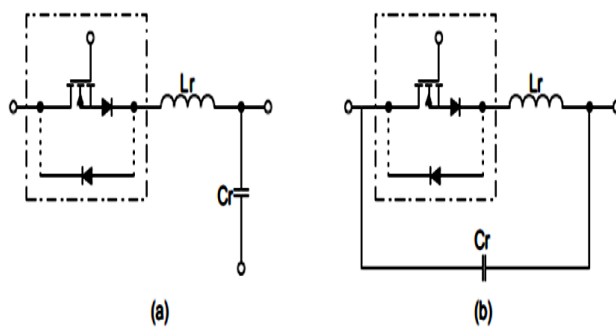
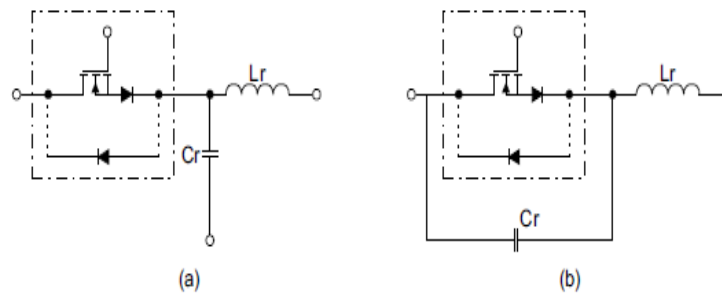

Fig 5. Two types of zero current (ZC) resonant switch

At turn-on, the switch current will rise slowly from zero. It will then oscillate because of the resonance between  $L_r$  and  $C_r$ . Finally, the switch can be commutated at the next zero current duration. The objective of this type of switch is to shape the switch current waveform during conduction time in order to create a zero-current condition for the switch to turn off.

#### A. ZV Resonant switch

In a ZV resonant switch, a capacitor  $C_r$  is connected in parallel with the switch  $S$  for achieving zero-voltage-switching. If the switch  $S$  is a unidirectional switch, the voltage across the capacitor  $C_r$  can oscillate freely in both positive and negative half-cycle. Thus, the resonant switch can operate in full-wave mode. If a diode is connected in anti parallel with the unidirectional switch, the resonant capacitor voltage is clamped by the diode to zero during the negative half-cycle. The fig 6 shows the two types of ZV switch.



**Fig 6. Two types of zero current (ZV) resonant switch**

The resonant switch will then operate in half-wave mode. The objective of a ZV switch is to use the resonant circuit to shape the switch voltage waveform during off time in order to create a zero voltage condition for the switch to turn on.

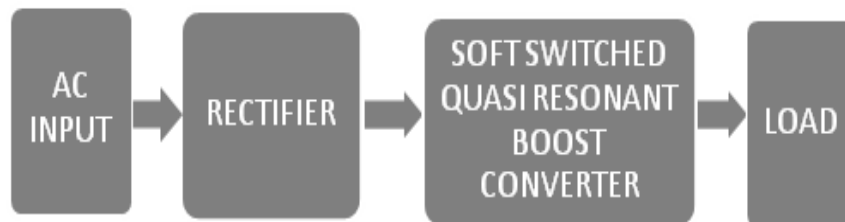
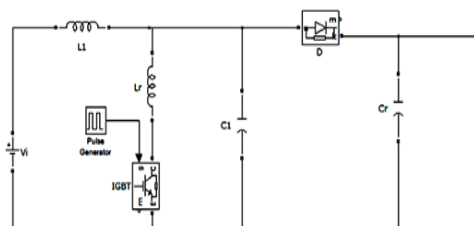

**Fig 7. Block diagram of soft switched multiple module quasi resonant boost converter**

The wind turbine output is rectified using diode bridge rectifier and given to the multiple-module cascaded quasi resonant converters. The fig 7 shows the Block diagram of Multiple-module Quasi-resonant Boost converter. The quasi resonant converter has an inductor and capacitor which is used to switch on the semiconductor device when the voltage or current is zero. It reduces the switching loss compared to the existing method. The voltage is boosted in each stage of quasi resonant boost converter. It is then connected to the load.

### A. Quasi Resonant Boost Converters

The word quasi resonant refers to the fact that these circuits are not continuously oscillating, but can be triggered by active components to perform a resonant cycle. The quasi resonant converter employs the resonance principle to achieve the lossless commutation, although it presents inherent pulse width-modulation characteristics. One resonant network is added to a quadratic boost converter which corresponds to two boost converters in cascade, where a single active switch is present. The fig 8 shows Quasi-resonant Boost Converter.



**Fig 8. Quasi-resonant Boost Converter**

A resonant inductor, a resonant capacitor, and an auxiliary switch form the resonant network. The auxiliary switch operates under ZCS condition because it is placed in series with the resonant inductors. This resonant inductor allows the main switch to operate under ZCS. In order to avoid overvoltage across the switch  $S$  and parasitic oscillation, due to reverse recovery of the body or external anti-parallel diode, the current unidirectional switch is used.

### B. IGBT in Resonant Converters

Resonant and quasi-resonant switching techniques have been widely used in high-frequency power conversion systems, leading to reductions in size, weight and power losses. By forcing the switching transitions to take place when there is either zero current through or zero voltage across the power switch allows the switching losses to be minimized. However, the necessary current or voltage rating of the device used is much higher than that required in a device used in a conventional hard-switching system, and so the devices are more expensive. MOSFETs are often chosen for the power switch in soft-switching applications, due to their high speed and easy drive. However, for medium and high power applications, their high conduction losses begin to cause problems, and IGBTs begin to become more attractive. Even in hard-switching applications, their higher current density, lower saturation voltages and high reliability mean that they are often used to replace MOSFETs.

## V. SIMULATION RESULTS

### A. Multiple-module Quasi-resonant Boost Converter

The Multiple-module Quasi-resonant Boost Converter uses a three-phase supply. The supply is rectified using rectifier and is connected to the Quasi-resonant boost converter. The Fig 9 shows the simulation diagram of Soft switched multi module quasi resonant boost converter.

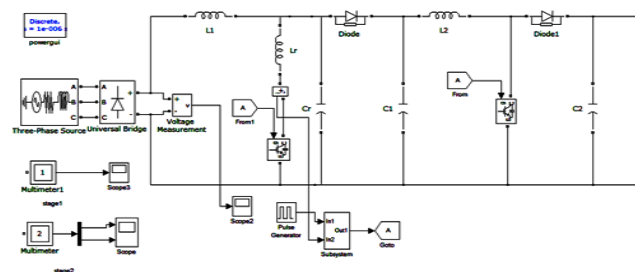
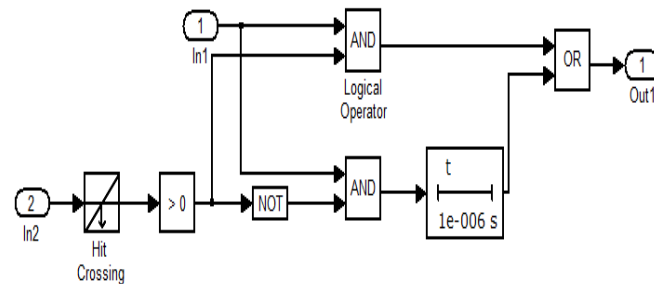

Fig 9. Simulation diagram of Soft switched quasi resonant boost converter

This converter has an additional component of  $L_r$  and  $C_r$ , along with the boost converter modules. The IGBT switch is used to reduce the conduction losses. Pulses are generated using pulse generator.

## B. Zero Crossing Sub-system



**Fig 10. Sub system component of Soft switched multi module quasi resonant boost converter**

The Fig 10 shows the sub system component of Soft switched multi module quasi resonant boost converter. The sub system is used for calculating the zero crossing. It uses a comparator and a logical operator. The comparator compares ten put voltage or current, and when it is greater than zero, the output is provided without any delay. If the value is not greater than zero then the current or voltage provided with some time delay.

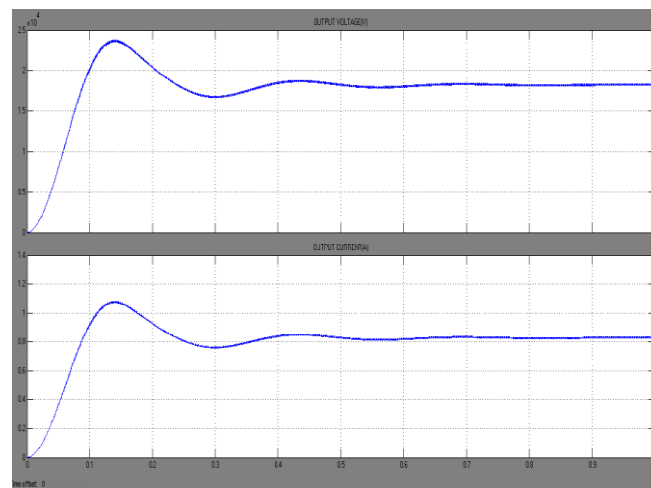

**Fig 11. Output waveforms of voltage and current**

The Fig 11 shows the output waveforms of voltage and current of Soft switched multi module quasi resonant boost converter. The input of 1.35KV is given and the voltage gets boosted 100 times and reaches up to 180KV. As the load connected is 22K $\Omega$ , the current is maintained nearly 8A.

## VI. CONCLUSION

The project deals with the use of Soft switched quasi resonant boost converter in the wind energy system to reduce the switching losses in the semiconductor devices during transmission. This approach is superior when



compared with the conventional methods, as the voltage is boosted by using cascaded boost converters unlike transformers. Cascade converters offer potential for large gains due to the multiplicative effect. The entire input power is processed twice, and the losses quickly become a limiting factor with large parasitic resistances. Interleaving can reduce parasitic resistances and inductor sizes while increasing reliability. The principle of quasi-resonant helps to operate at zero-voltage or zero current, hence reducing the switching losses. The system is simulated using MATLAB SIMULINK and the boosting of voltage is analyzed. The future enhancement is to introduce dual-switch or fly back converter instead of LLC resonant converters.

## REFERENCES

- [1] S. Nishikata and F. Tatsuta, "A new interconnecting method for wind turbine/generators in a wind farm and basic performances of the integrated system," *IEEE Trans. Ind. Electron.*, vol. 57, no. 2, pp. 468–475, Feb. 2010.
- [2] L. Wei, G. Joos, and J. Belanger, "Real-time simulation of a wind turbine generator coupled with a battery super-capacitor energy storage system," *IEEE Trans. Ind. Electron.*, vol. 57, no. 4, pp. 1137–1145, Apr. 2010.
- [3] E. Firmansyah, S. Tomioka, S. Abe, M. Shoyama, T. Ninomiya: "Zero-Current-Switch Quasi-Resonant Boost Converter in Power Factor Correction Application", the Applied Power Electronics Conference and Exposition 2009, Washington DC, US, 2009, pp. 1165-1169.
- [4] M. Borage, K. V. Nagesh, M. S. Bhatia, and S. Tiwari, "Design of LCL-T resonant converter including the effect of transformer winding capacitance," *IEEE Trans. Ind. Electron.*, vol. 56, no. 5, pp. 1420–1427, May 2009.
- [5] J. W. Kimball, J. T. Mossoba, and P. T. Krein, "A stabilizing, high performance controller for input series–output parallel converters," *IEEE Trans. Power Electron.*, vol. 23, no. 3, pp. 1416–1427, May 2008.
- [6] L. Wuhua and H. Xiangning, "An interleaved winding-coupled boost converter with passive lossless clamp circuits," *IEEE Trans. Power Electron.*, vol. 22, no. 4, pp. 1499–1507, Jul. 2007.
- [7] R. J. Wai, C. Y. Lin, L. W. Liu, and Y. R. Chang, "High-efficiency single stage bidirectional converter with multi-input power sources," *Elect. Power Appl., IET*, vol. 1, no. 5, pp. 763–777, Sep. 2007.
- [8] V. Vorperian, "Synthesis of medium voltage dc-to-dc converters from low-voltage, high-frequency PWM switching converters," *IEEE Trans. Power Electron.*, vol. 22, no. 5, pp. 1619–1635, Sep. 2007.
- [9] R. Giri, V. Choudhary, R. Ayyanar, and N. Mohan, "Common-duty-ratio control of input-series connected modular dc–dc converters with active input voltage and load current sharing," *IEEE Trans. Ind. Appl.*, vol. 42, no. 4, pp. 1101–1111, Jul./Aug. 2006.

- [10] J. C. Fothergill, P.W. Devine, and P.W. Lefley, "A novel prototype design for a transformer for high voltage, high frequency, high power use," IEEE Trans. Power Del., vol. 16, no. 1, pp. 89–98, Jan. 2001.
- [11] D. Czarkowski and M. K. Kazimierczuk, "Energy-conservation approach to modelling PWM DC–DC converters," IEEE Trans. Aerosp. Electron. Syst., vol. 29, no. 3, pp. 1059–1063, Jul. 1993.
- [12] S. D. Johnson, A. F. Witulski, and R. W. Erickson, "Comparison of resonant topologies in high-voltage DC applications," IEEE Trans. Aerosp. Electron. Syst., vol. 24, no. 3, pp. 263–274, May 1988.