

IOT Based Power Management implementation for Smart Home Systems

Vaddi Naga Padma Prasuna, Shilpa M.N, Dulipala Jagannadham

^{1,2}*Dept. of ECE, Atria Institute of Technology, Bangalore, (India)*

³*Research Scholar, Anna University, Chennai, (India)*

ABSTRACT

In today's world sensors are playing a role in every field. Internet of Things (IOT) represents the interconnection and exchange of data between the sensors and the users through internet. This paper highlights implementation of Smart Home automation for monitoring and management of power using IOT technology. A set of Wireless sensor nodes used for monitoring, controlling of home power systems and communicates the data to the users through internet over Amazon cloud.

Keywords- *Amazon cloud server, IOT, IR sensors, Renesas, Magnetic Switch*

I. INTRODUCTION

Internet of Things (IOT) is the network of smart electronic systems connected by a common synchronized network path for the data transfer and communication protocols for exchanging information amongst one another. The flow of data from the smart components can either happen through hardware or software.

It refers to an information hub wherein the data flows from multiple systems and components into a common network and which gets integrated to produce information and make this information available to the data cloud by being a part of the World Wide Web. It is not only limited to the internet connectivity but also features the data management, security and extends to all areas concerned with the era of internet

In this era of internet and technology where there is an exponential growth of technology year by year. This technology has given birth to smart intelligent systems. These systems have become a part of our lives, making our day to day activities easier and operate with no human interventions and making the devices capable of taking smart decisions.

II. LITERATURE SURVEY

Gubbi, J., Buyya, R., Marusic, S., & Palaniswami, M. (2013). discussed about a cloud centric vision for worldwide implementation of Internet of Things. They also discussed about a cloud implementation using Aneka, which is based on interaction of private and public clouds and discussed about IoT vision by expanding on the need for convergence of WSN, the Internet and distributed computing directed at technological research community [1].

Kelly, S. D. T., Suryadevara, N. K., & Mukhopadhyay, S. C. (2013) The author discussed proposed an efficient method for internetworking of 802.15.4 with IP network. They discussed a low-cost solution and flexible connection mechanisms for integrating Internet of things with home monitoring systems [2].

R. Piyare and M. Tazil The author discussed the implementation of wireless home automation. Their proposed model can be used as a test bed for any appliances. Their proposed model is based on Arduino BT board and other home appliances are interconnected via relays. The author highlighted that their model is available at low cost and scalable allowing variety of devices to be controlled with minimum changes to its core. The other important feature of their model is password protection for authorized users from accessing the appliances at home [3, 4]

III. PROPOSED MODEL

A single microcontroller based modular design has been proposed for power management and controlling of Smart Home implementation. The microcontroller with structured modular design has been implemented as shown in Figure 1.

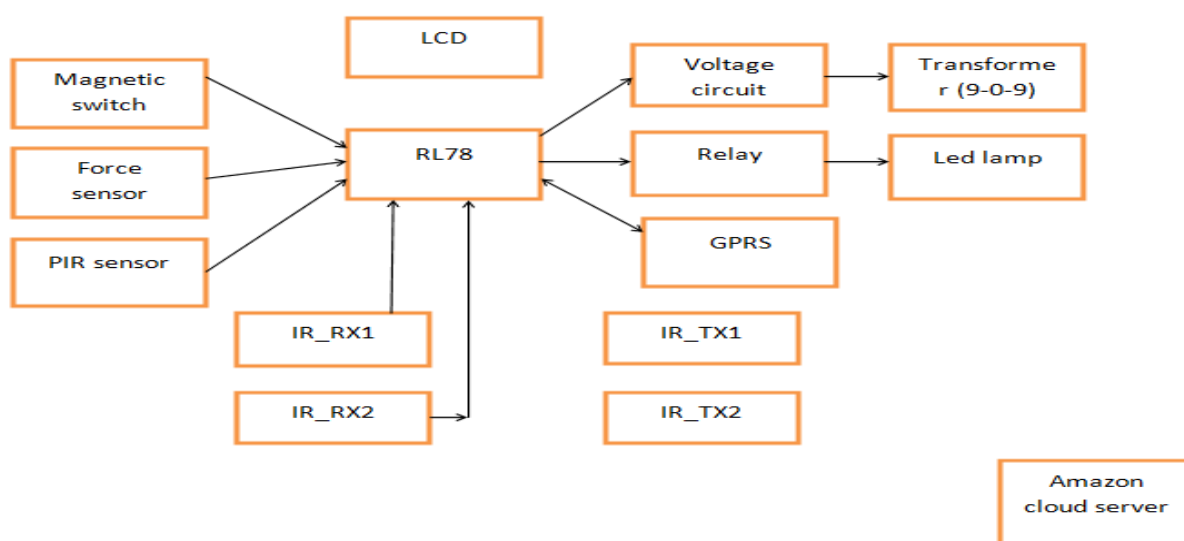

Figure 1: Block diagram of proposed Model

The proposed microcontroller implemented using RL8, LCD, Force sensor, PIR sensor, Magnetic door switch, Relay, voltage divider, IR transceiver and a GPRS module. The microcontroller is placed at the centre and acts as a controlling unit for power management. Controlling logic has been implemented as a part of the microcontroller itself and performs action based on the inputs received from the user over wireless channel. This proposed model has two nodes namely Server Node and Sensor Node. Server Node consists of database table used to store the collected data from the sensor node(s) and the sensor node to collect the data. In today's technology sensor plays a prominent role in every field [6,7].

IV. WORKING PRINCIPLE

Every system has control unit and performs Input and output functions this performed I/O functions are stored in a storage device or storage area called memory. The input devices connected to the renesas microcontroller are magnetic door switch, PIR sensor, IR sensor, force sensor. The output devices are LCD, Voltage circuit, transformer, relay, LEDlamp, GPRS and Amazon cloud server.

Magnetic switch: Is used to demonstrate automatic door open/close thus by providing security management.

Force sensor: Is used to detect any intruder in corridors of home and presence of person in some passages.

PIR sensor: Is used to detect the motion around home corridors.

IR sensor: Are used for low power consumption. Here this system uses pair of two IR sensors which is used to monitor the number of people entered or left. And lights are tuned on/off automatically whenever the persons enters or leaves the room. The person should cross two IR sensors so that the count is monitored and provides lightning accessibility.

LCD: It is an output device it is used demonstrate or display the output.

LED Lamp: Used as lights in this system and a relay has been used to switch these lights.

Transformer: The electrical devices can be automatically turned on/off depending on the supplied power through transformer.

GPRS: It is a general packet radio service used for communicating wirelessly and also to provide an interaction between sensor node and server node.

Amazon server: It is a service which is offered by one device to other electronic device which is used for communicating between each other. It is also software design which supports interaction of machine to machine over a network & via World Wide Web.

V. IMPLEMENTATION MODEL

The PIR sensor is used to detect motion around home, force sensor is used to detect any presence in some passages/corridors areas in home, magnetic switch is used for automatic door open and close thus the security management. The two pair of IR sensors is used for demonstrating power management (commercial buildings, hotels, visitor area, conference hall etc..) through IR sensor the number of people entered and left count is monitored , based on the count the light accessibility is provided, The person entering room should cross the two IR sensor the it is considered has person entered room so the lights switched ON automatically and people leaving the room is also monitored via IR sensor and count is monitored, based on the count lights switched OFF automatically. The electrical appliances are turned ON/OFF depending on the power supply and it is demonstrated using transformer (9-0-9). A prototype of the proposed implementation model is as shown in Figure 2.

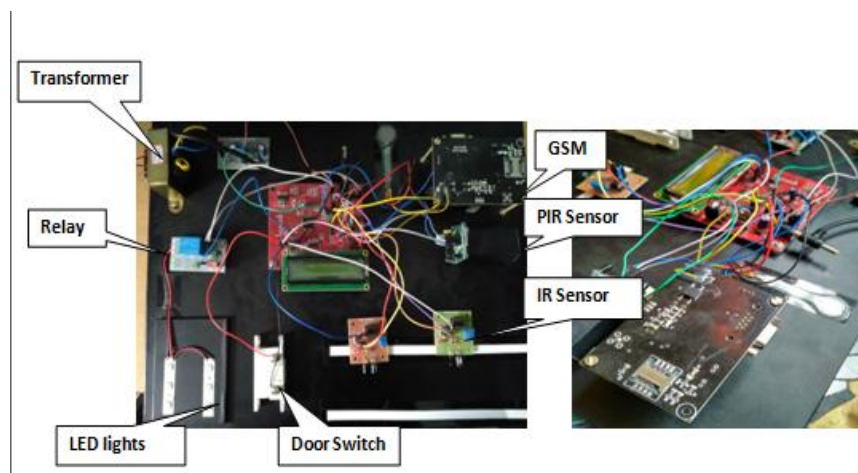

Figure 2. Implementation model of the proposed model

VI. ALGORITHM AND RESULTS

An algorithm has been implemented with the prototype as shown in below Figure 3A and corresponding LCD display showing the detection of an intruder, in Figure 3B.

Step1: Start and power on the sensor node.
Step2: Sensor node start monitor the power system.
Step 2A: An optional motion sensor node start sense motion in the given range.
Step3: The analog values and are converted to digital values using ADC.
Step4: Different sensors values are displayed on LCD.
Step5: Sensed data has been communicated to the server node through GPRS.
Step6: Server Node send notification message to the user through an Email or other mediums.

Figure 3A: Algorithm used for prototype implementation model



Figure 3B. LCD display showing the intruder detection.

VII. CONCLUSION

In this paper we presented an implementation model for Smart Home power monitoring and controlling. The proposed model has been implemented using additional security for intruder detection and controlling of power system. The algorithm used for realtime monitoring and remote controlling of the power system of a Smart Home has been detailed. The remote user has been implemented using a server node over amazon cloud server.

REFERENCES

- [1] Gubbi, J., Buyya, R., Marusic, S., & Palaniswami, M. (2013). Internet of Things (IoT): A vision, architectural elements, and future directions. *Future generation computer systems*, 29(7), 1645-1660.
- [2] Kelly, S. D. T., Suryadevara, N. K., & Mukhopadhyay, S. C. (2013). Towards the implementation of IoT for environmental condition monitoring in homes. *IEEE Sensors Journal*, 13(10), 3846-3853.
- [3] R. Piyare and M. Tazil, "Bluetooth based home automation system using cell phone", in Consumer Electronics (ISCE), 2011 IEEE 15th International Symposium on, 2011, pp. 192-195.
- [4].Honeywell Automation: <https://homesecurity.honeywell.com>
- [5] Sandeep Patel, Punit Gupta, Mayank Kumar Goyal, "Low Cost Hardware Design of a Web Server for Home Automation Systems", Conference on Advances in Communication and Control Systems(CAC2S), 2013.

- [6] Apoorva S, Khadeer Ahmed, Rachana, Vaddi Naga Padma Prasuna, “ Complete Irrigation solution using Wireless Sensor Networks” in International Journal of Advanced Research in Electronics and Communication Engineering, Volume.5.Issue.4.,April-2016,pp..1092.- .1095
- [7] Monika, Manasa.S, Sujay, Vaddi Naga Padma Prasuna, “Li-ion Battery Supercapacitor Based Hybrid Storage System in Wireless Sensor Networks ” in International Journal of Advanced Research in Electronics and Communication Engineering, Volume.5.Issue.4.,April-2016,pp..1146.-.1150