

# **IOT BASED TRANSFORMER PARAMETER MONITORING**

**Kalyani Mandekar<sup>1</sup>, Purva Apte<sup>2</sup>, Ketki Chaudhari<sup>3</sup>, Minza Ansari<sup>4</sup>**

*<sup>1,2,3,4</sup>Department of Electrical Engineering,  
Guru Gobind Singh Polytechnic Nashik, Maharashtra, (India)*

## **ABSTRACT**

*Distribution transformers are one of the most important equipment in power network. Because of, the large number of transformers distributed over a wide area in power electric systems, the data acquisition and condition monitoring is a important issue. The main aim of this system is distribution transformer monitoring and controlling through GSM modem. Here transformers are damaged due to the oil damage. Oil damage is depends on different parameters and environmental conditions. Now in this system we are concentrating on temperature of transformer and viscosity of oil .In this system temperature and viscosity monitoring and control action is performed based on the AVR microcontroller. After interfacing the required components user has to develop one application program in embedded-c. Here controller is continuously reading the temperature, voltage and current and display on the LCD.*

## **I INTRODUCTION**

Distribution transformers have a long service life if they are operated under good and rated conditions. However, their life is significantly reduced if they are overloaded, resulting in unexpected failures and loss of supply to a large number of customers thus effecting system reliability. Overloading and ineffective cooling of transformers are the major causes of failure in distribution transformers. Most power companies use Supervisory Control and Data Acquisition (SCADA) system for online monitoring of power transformers but extending the SCADA system for online monitoring of distribution transformers is an expensive proposition. Distribution transformers are currently monitored manually where a person periodically visits a transformer site for maintenance and records parameter of importance. This type of monitoring cannot provide information about occasional overloads and overheating of transformer oil and windings. All these factors can significantly reduce transformer life. Our system is designed based upon online monitoring of key Operational parameters of distribution transformers can provide useful

Information about the health of transformers which will help the utilities to Optimally use their transformers and keep the asset in operation for a longer Period. This system will help us to identify problems before any catastrophic Failure, thus resulting in a long life service for transformers. This system is based on embedded system as we are using microcontroller as discussed before. Embedded systems are self-contained programs that are embedded within a piece of hardware. embedded systems are usually set to a specific task Another way to think of an embedded system is as a computer system that is created with optimal efficiency, thereby allowing it to complete specific functions as quickly as possible. It is also has the advantages of significant cost savings, power consumption and greater reliability.

## II. BASIC BLOCK DIAGRAM OF SYSTEM

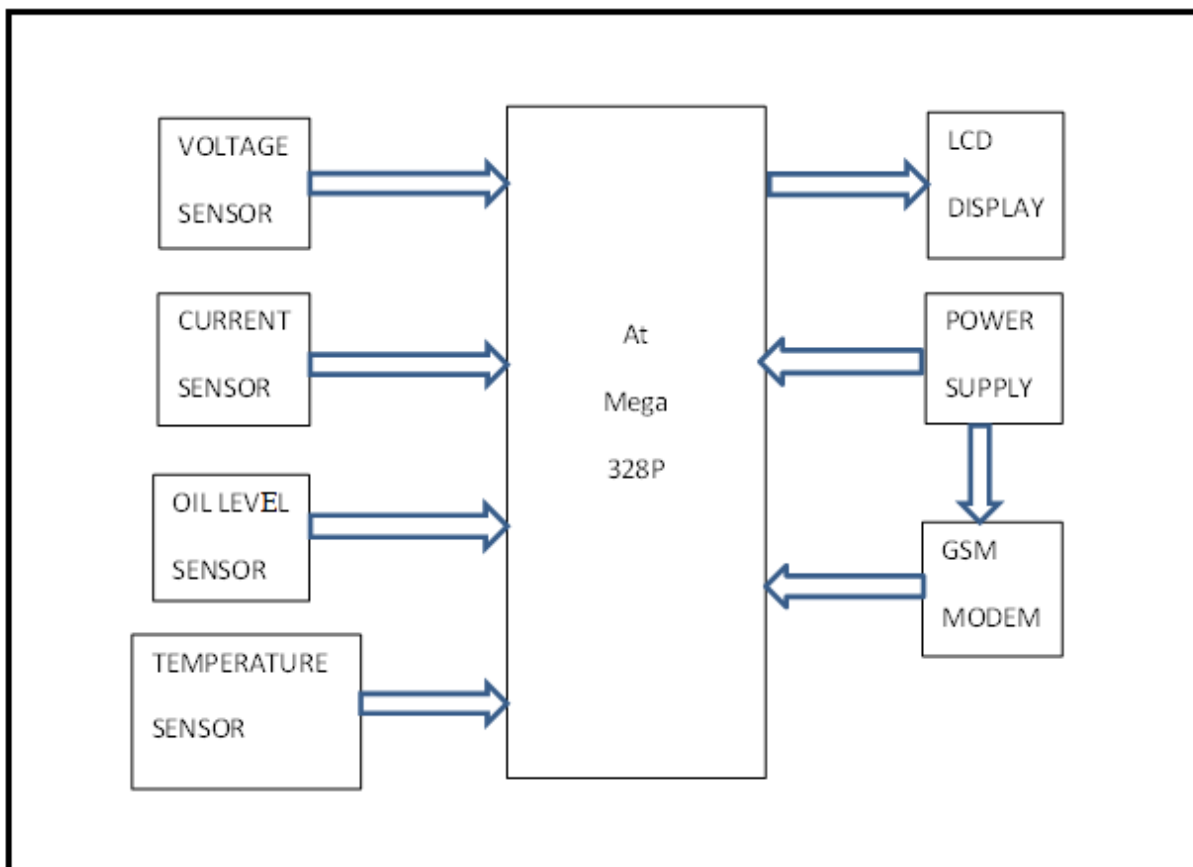

**Figure: Block Diagram of Transformer monitoring system**

### **III. DESCRIPTION**

Our system is designed based upon online monitoring of key Operational parameters of distribution transformers can provide useful Information about the health of transformers which will help the utilities to Optimally use their transformers and keep the asset in operation for a longer Period. This system will help us to identify problems before any catastrophic Failure, thus resulting in a long life service for transformers. In transformer monitoring system we used four sensors for monitoring that is voltage sensor, current sensor, temperature sensor and oil level sensor. We used power supply to operate microcontroller AT mega 328P and GSM module. Fig shows the connection between microcontroller and all other modules. Sensors sense the data and display it on LCD display at the same time GSM module send the message(data) to user on given number as per program. If we get any unsecure data about transformer we can avoid failure.

#### **VOLTAGE SENSOR**

A voltage sensor is a device which detects the celectric voltage in a wire, and generates aq signal proportional to it. The generated signal could be analog voltage or current or even digital output. It can be then utilized to display the measured voltage in a voltmeter or can be stored for further analysis in a data acquisition system or can be utilized for control purpose.

#### **CURRENT SENSOR**

A **current sensor** is a device that detects electric current (AC or DC) in a wire, and generates a signal proportional to it. The generated signal could be analog voltage or current or even digital output. It can be then utilized to display the measured current in an ammeter or can be stored for further analysis in a data acquisition system or can be utilized for control purpose.

The sensed current and the output signal can be:

- Alternating current input,  
analog output, which duplicates the wave shape of the sensed current.  
bipolar output, which duplicates the wave shape of the sensed current.  
unipolar output, which is proportional to the average or RMS value of the sensed current.
- Direct current input,  
unipolar, with a unipolar output, which duplicates the wave shape of the sensed current  
digital output, which switches when the sensed current exceeds a certain threshold

### **OIL LEVEL SENSOR**

Oil level sensor is a device which is used to check the oil level in the transformer. Due to over heating the oil start to evaporate and the oil level decreases and thus this decrease in the oil level may be dangerous to the transformer. Thus this sensor indicates the level and we get aware about the level. Thus we can look over the oil viscosity also.

### **TEMPERATURE SENSOR**

Temperature sensor vary from simple ON/OFF thermostatic devices which control a domestic hot water heating system to highly sensitive semiconductor types that can control complex process control furnace plants.

We remember from our school science classes that the movement of molecules and atoms produces heat (kinetic energy) and the greater the movement, the more heat that is generated. **Temperature Sensors** measure the amount of heat energy or even coldness that is generated by an object or system, allowing us to “sense” or detect any physical change to that temperature producing either an analogue or digital output.

There are many different types of **Temperature Sensor** available and all have different characteristics depending upon their actual application

### **ATMEGA 328P**

The Atmel 8-bit AVR RISC-based microcontroller combines 32 kB ISP flash memory with read-while-write capabilities, 1 kB EEPROM, 2 kB SRAM, 23 general purpose I/O lines, 32 general purpose working registers, three flexible timer/counters with compare modes, internal and external interrupts, serial programmable USART, a byte-oriented 2-wire serial interface, SPI serial port, 6-channel 10-bit A/D converter (8-channels in TQFP and QFN/MLF packages), programmable watchdog timer with internal oscillator, and five software selectable power saving modes. The device operates between 1.8-5.5 volts. The device achieves throughput approaching 1 MIPS per MHz.

### **LCD Module**

In recent years the LCD is finding widespread use replacing LEDs (Seven Segment LEDs or other multistage LEDs). The ability to display numbers, characters and graphics. This is in contrast to LEDs, which are limited to numbers and a few characters.



#### **IV. ADVANTAGES**

- We Can Sit At Any Place And Access It Using Internet
- We Can Control The System Or The Equipment Using GPRS
- It Is Economical Compared To The SCADA System Used.

#### **V. APPLICATIONS**

- Used to control equipments
- Can also control the system

#### **VI CONCLUSION**

The IOT based monitoring of distribution transformer is quite useful as compared to manual monitoring and also it is reliable as it is not possible to monitor always the oil level, ambient temperature rise ,load current manually. After receiving of message of any abnormality we can take action immediately to prevent any catastrophic failures of distribution transformers. In a distribution network there are many distribution transformers and associating each transformer with such system, we can easily figure out that which 42 transformer is undergoing fault from the message sent to mobile. We need not have to check all transformers and corresponding phase currents and voltages and thus we can recover the system in less time. The time for receiving messages may vary due to the public GSM network traffic but still then it is effective than manual monitoring.

#### **VII RESULT**

This system would be eliminating the requirement of human power and thus providing efficiency and accuracy. This paper will give accurate details of energy theft. It will help to manage sensing the parameters and also record details for electricity theft.

This paper will also assure the safety and help in decrease in theft level & would not result in any harm to the environment and surroundings.

#### **REFERENCES**

- 1) Design of Intelligent Traffic Light Controller Using Embedded System
- 2) Shilpa S. Chavan; R. S. Deshpande; J. G. Rana
- 3) Smart GSM based Home Automation System
- 4) Rozita Teymourzadeh; Salah Addin Ahmed; Kok Wai Chan; Mok Vee Hoong
- 5) Energy Consumption Estimation in Embedded Systems
- 6) Konstantakos; A. Chatzigeorgiou; S. Nikolaidis; Th. Laopoulos

- 7) Embedded system-based mobile patient monitoring device
- 8) A.R. Al-Ali; M. Al-Rousan; M. Al-Shaikh
- 9) A platform FPGA-based hardware-software undergraduate laboratory
- 10) J. Schneider; M. Bezdek; Ziyu Zhang; Zhao Zhang; D.T. Rover
- 11) Applying software product line techniques in model-based embedded systems engineering
- 12) Andreas Polzer; Stefan Kowalewski; Goetz Botterweck