

E – STREET: LED POWERED INTELLIGENT STREET LIGHTING SYSTEM WITH AUTOMATIC BRIGHTNESS ADJUSTMENT BASED ON CLIMATIC CONDITIONS AND VEHICLE MOVEMENTS

**Seema Kailas Panjage¹, MokshadaKishor Gajare², KalpanaBhagwan Late³,
UttaraRaghunath Chaudhari⁴, SayaliKamlakar Pisolkar⁵, AmolBaban
Manghale⁶**

*^{1,2,3,4,5,6} Department of Electrical Engineering,
Guru Gobind Singh Polytechnic, Nashik, Maharashtra, (India)*

ABSTRACT

Monitoring of street lights and controlling is of utmost importance in developing country like India to reduce the power consumption. The paper presents a remote streetlight monitoring and controlling system based on LED and wireless sensor network. The system can be set to run in automatic mode, which control streetlight. This control can make reasonable adjustment according to the seasonal variation. Also this system can run in controlled mode. In this mode, we can take the initiative to control streetlights through PC monitor terminal. This street light system also includes a time cut-out function, and an automatic control pattern for even more electricity conserving, namely when vehicles pass by, the light will turn on automatically, later turn off. This design can save a great amount of electricity compared to streetlamps that keep a light during nights. The design implements traffic flow magnitude statistics without adding any hardware, facilitating transportation condition information collecting. Furthermore, this system has auto-alarm function which will set off if any light is damaged and will show the serial number of the damaged light, thus it is easy to be found and repaired the damaged light. The system can be widely applied in all places which need timely control such as streets, stations, mining, schools, and electricity sectors and so on. In addition, the system integrates a digital temperature and humidity sensor, not only monitoring the streetlight but also temperature and humidity.

Index Terms: Energy Conservation, Infrared Detection, Street Light Control System, Wireless Sensor Network.

I. INTRODUCTION

In recent years, environmental issues have gained widespread international attention, resulting in the development of energy-efficient technologies aimed at reducing energy consumption. One aspect of this evolving situation is an increasing demand for a reduction in the amount of electricity used for illumination. In particular, energy conservation for large scale illumination tasks such as street lighting is gaining considerable importance. Most outdoor illumination sources, such as street lights use HID Lamps as light sources. Global concerns have been raised regarding the amount of power consumed by HID lamps and by extension, the amount of atmospheric CO₂ released due to such power consumption. Due to this issue, LED array illumination has received attention recently as an energy reducing light source. LED illumination requires about one third to one half of the electric power needed for HID lighting. The lifecycle of an LED can be more than three times as long as an HID light. LED illumination could reduce the amount of time needed to exchange defective fixtures, and it is expected that an LED system would be comparatively maintenance free. This in turn, means that LED system could be considered suitable for use on isolated islands or in high mountainous regions. In such a background, and as a result of the significant improvements to luminescent efficiency in recent years, LED lighting can be expected to fully replace previously used light sources within our lifetimes. The anticipated development of LED illumination is shown in Figure 1.

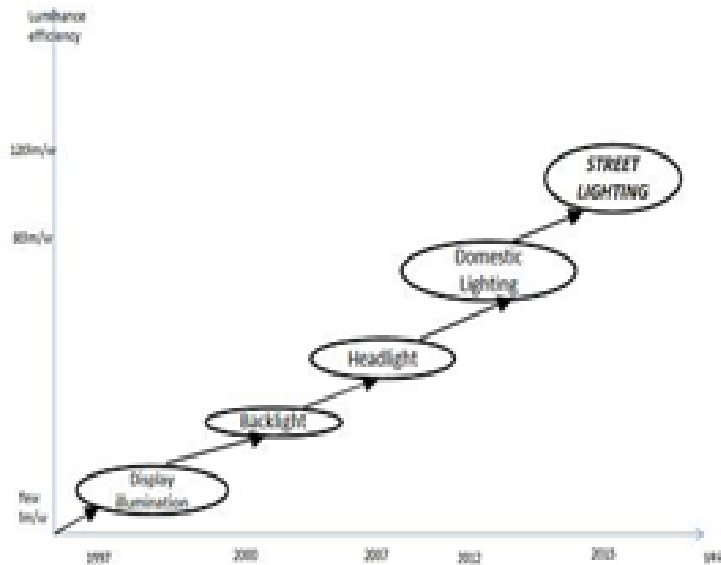

Figure-1 Past history and projected expansion of the LED

Lighting system particularly in the public sector, still works as per the previous standards of reliability and they don't insist the use of latest technological developments. Recently, however, the increasing pressure associated with the increase in raw material prices and the increase of CO₂ emissions leads to the development of new techniques and technologies which permit significant cost savings. Three methodologies are used in latest technology and they

are as listed below. (a) Initially, Remote intelligent system has been proposed in order to increase the efficiency of the led as well to save considerable amount of energy. This is done through controlling the street lights through a central monitoring unit via IEEE 802.15.4 wireless protocol. (b) Secondly, the led in the street lamps are switched ON only if there is any kind of movement such as, human movement or vehicle movement. Adding to that the dimming technology is also used to save considerable amount of energy. (c) Thirdly, the street lamps can be controlled annually by the EB station through the same wireless medium.

II. RELATED WORKS

Energy savings are of utmost importance today. The goal is therefore, the reduction of operating prices of street lighting with the creation of a system characterized by straightforward installation and low power consumption. A multi-functional street light control system based on PIC16F877A was presented. This system includes a time cut-out function and an automatic control pattern for electricity conservation. This design can save a great amount of electricity compared to street lamps that kept ON during nights. Furthermore, this system has auto-alarm function which will set ON if any light is damaged and will show the serial number of the damaged light, thus it is easy to be found and repaired the damaged light. In this paper, a simpler, multipurpose, cost-effective design to control the on-off mechanism of street lights. The terminal has the feature of running on the network and off the network independently, so it ensures the stability of the system. In order to reach a high performance level in a street lighting control system, two important aspects must be taken into account: the selection of the adequate communication protocol, on the one hand, and the selection of the network topology that supports the architecture, on the other hand. Taking into consideration these circumstances, this paper focuses on an assessment of the performance of the mesh and tree network topologies which, along with the Mi-Wi communication protocol, can be implemented in a street lighting control architecture. As a result of the simulations that have been conducted, the data reveals that the tree topology is much more efficient than the mesh topology. An innovative wireless street lighting system with optimized management and efficiency has been presented in this paper. Wireless communication based on Mi-Wi wireless devices which allow more efficient street lamp system management, advanced interface and control architecture are used. The Information is transferred through point-by-point using Mi-Wi transmitters and receivers to a control terminal to diagnose different conditions of street lights.

III. ARCHITECTURE OF THE REMOTE STREET LIGHT CONTROL SYSTEM

The system is designed as a modular system, easily extendable. The measuring stations are used to observe street conditions depending on the intensity of daylight, based on the conditions they activate or off the lamps. Other factors influencing the activation are: climatic conditions, seasons, geographical location, and many possible alternative factors.

For these reasons every lamp is designed independent to decide about the activation of light. The base station Co-

jointly checks if any lamp is correctly operating and sends the message using the wireless network to the operator who will act in case of malfunction

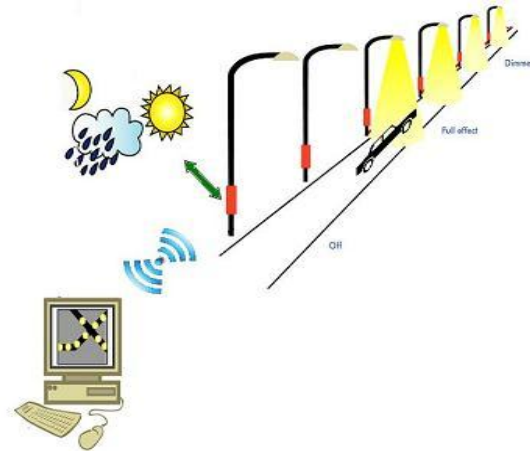

Figure-2 Schematic of E-Street light system

The Fig 2 shows the function of the E-street. The streetlights are switched ON when the vehicles come near the lamp. The led in the street lamp are set to DIM condition when the vehicle or human crossed the first lamp and reaches the second lamp. This dimming of led is controlled using PWM technique. All these data's are sent through wireless communication to the base station and the controlling part also done in base station.

IV.DESIGN OF HARDWARE

The block diagram of proposed street lights control system is shown in Figure 3(a) and Figure 3(b). The transmitter end consists of a power supply, microcontroller PIC16F877A, photosensitive detection circuit (Day & night sensor), infrared vehicle detector, feedback circuit, fault detection circuit, LCD display and Mi-Wi transmitter module. The receiver part consists of Mi-Wi receiver module, MAX232, RS232 and PC. The block diagram explains the simple working of the whole system developed.

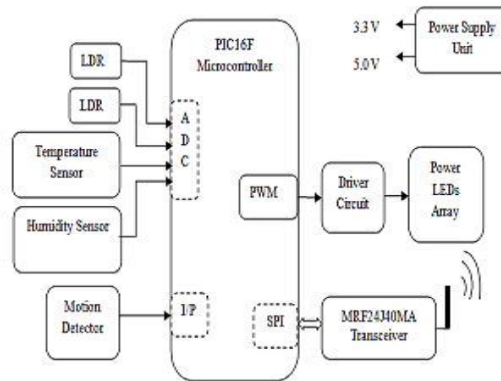

Figure-3(a): Transmitter end diagram

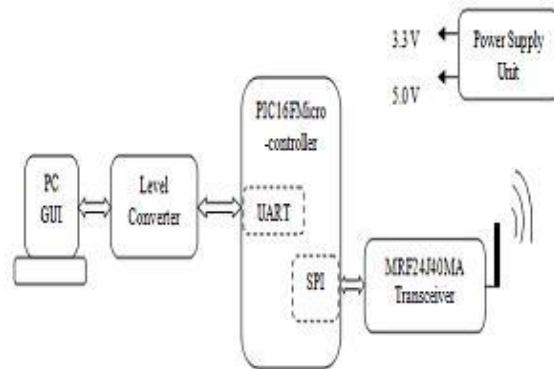

Figure-3(b): Receiver end diagram

The power supply circuit provides the 5V regulated power supply for revitalizing the microcontroller module. The core of the system is a PIC16F877A microcontroller. It is preferred because of the following features: - it is low-power, high-performance enhanced flash 8-bit microcontroller with 8K Bytes of in-system programmable Flash memory, 256 bytes of RAM, 32 I/O lines, three 16-bit timer/counters, a full duplex serial port, on-chip oscillator, and supports two software selectable power saving modes: low power Idle and Power-down mode. The photosensitive detection circuit consists of Day & night sensor to determine the external light intensity. The threshold (reference) illumination level is set initially. The photoelectric sensor with set threshold intensity is used to observe street conditions as the intensity of daylight is high or low, depending on the conditions they activate or off the lamps. The street lamps still consume a lot of electricity when merely a few vehicles are driving around the road. Thus, there is a great necessity to develop a control system based on the traffic flow density. Whenever there is no traffic i.e. density of traffic is zero, there is no need of street light to be glow on highways which saves power consumption to a greater extent. The lights in a particular area should glow only when a vehicle enters that area on highways. For this purpose, the infrared detection circuit has been used. It consists of IR sensor (presence sensor) which has the task of identifying the passage of a vehicle or pedestrian causing the switching ON/OFF of street lamps. This feature permits to activate lamps solely when necessary, avoiding wastage of energy. The load which is street-light lamps is connected to microcontroller. Using power transistors and solid state dual relays, the street-lamps are switched ON/OFF. The solid state relays accept the triggering voltage from power transistors which in turn are triggered by microcontroller on, reception of activation signals from the sensors. Pulse width Modulation or PWM is one of the powerful techniques used in control systems today. They are not only employed in wide range of control application which includes: speed control, power control, measurement and communication. This PWM technique switches the power supply 5v to 3.3v for dimming purpose. These dimming purposes save the great amount of power consumption. The fault detection circuit indicates the LED lamp failure as well as wire fault along the lamp and wire number when the lamps are firstly turned on, and sensing the night. Through feedback circuit the malfunctioning message is transmitted to the controller which displays it on the LCD and also transmitted wirelessly

through Mi-Wi module to the control terminal. The LCD display is used to show different conditional messages like day, night, light testing, wire fault, LED failure, etc. The sensors transfer the collected information to a controller that runs the software to manage the system. The Compact and complete, easy to use PIR Sensor Module for human body detection. Incorporating a Fresnel lens and motion detection IC, suitable for a wide range of supply voltages and with low current drain. Adjustable delay time with high sensitivity and low noise. Output is a standard TTL output signal. The features of PIR sensors are Complete with PIR, Motion Detection IC and Fresnel Lens, Dual Element Sensor with Low Noise and High Sensitivity, Supply Voltage: 5 -20Vdc, Delay Time Adjustable: 5 seconds to 18 Minutes, Standard TTL Output, Module Dimensions: 28mm Length, 38mm Width, 40mm Height. In addition, the system integrates a digital temperature and humidity sensor, not only monitoring the streetlight but also temperature and humidity. The MCP9800 is a digital temperature sensor capable of reading temperatures from -55°C to +125°C. Temperature data is measured from an integrated temperature sensor and converted to digital word with a user selectable 9 to 12-bit Sigma Delta Analog to Digital Converter. The MCP9800 notifies the host controller when the ambient temperature exceeds a user programmed set point. The ALERT output is programmable as either a simple comparator for thermostat operation or as a temperature event interrupt. Communication with the sensor is accomplished via a two-wire bus that is compatible with Mi-Wi standard protocols. This permits reading the current temperature, programming the set point and hysteresis and configuring the device. Small physical size, low installed cost and ease of use make the MCP9800 an ideal choice for implementing sophisticated temperature system management schemes in a variety of applications. All the operation is regulated by a timing management that permits the system is set for predestined time. The Mi-Wi transmission module (Series S2) connected to microcontroller receives data of the state of the lamps and sends it to a Mi-Wi receiver module which is connected with control terminal processing unit (base station) . The operating voltage required for Mi-Wi module is 3.3V. It is achieved by using low dropout voltage regulator LM2950 which uses 5V as input from regulated power supply section and provides 3.3V output to energize the Mi-Wi module. The processing unit consists of a terminal with a serial UART (RS232) interface that receives data regarding the state of the lamps provided by a MI-Wi receiver module, connected to the UART interface. The terminal is needed for graphical presentation of the system results. The graphical interface permits to visualize the state of the system with the state of the lights and the power consumption of every lamp (Power Consumption Data graph). The MRF24J40MA is a 2.4 GHz IEEE Std. 802.15.4 compliant, surface mount module with integrated crystal, internal voltage regulator, matching circuitry and PCB antenna. The MRF24J40MA module operates in the non-licensed 2.4 GHz frequency band and is FCC, IC and ETSI compliant. The integrated module design frees the integrator from extensive RF and antenna design, and regulatory compliance testing, allowing quicker time to market. The MRF24J40MA module is compatible with Microchip's ZigBee, MiWi and MiWi P2P software stacks. The MRF24J40MA module has received regulatory. Approvals for modular devices in the United States (FCC), Canada (IC) and Europe (ETSI). Modular approval removes the need for expensive RF and antenna design and allows the end user to place the MRF24J40MA module inside a finished product and not require regulatory testing for an intentional radiator (RF transmitter). UART stands for the

Universal Asynchronous Receiver/Transmitter. In asynchronous transmitting, teletype-style UARTs send a "start" bit, five to eight data bits, least-significant-bit first, an optional The basic block diagram plays an important role in building the project completely and to provide a basic understanding of the working of the system. All blocks in the diagram are implemented in the circuit level. The minimal circuit of system is as shown in the Figure 4.

V. STREET LIGHT AUTOMATIC CONTROL METHODOLOGY

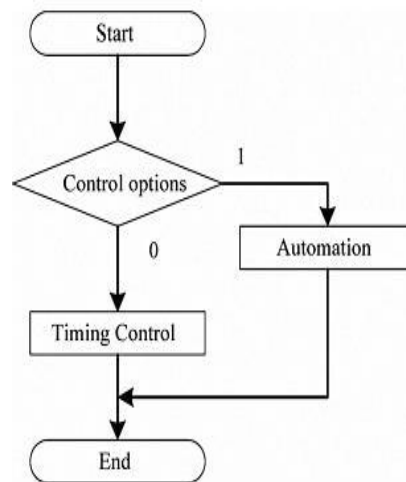

Fig 5: Flow Chart of Main control

Fig 5 shows the flow chart of main control, initially in night time all the street lights are activated because of poor ambient light condition. The street lights are operated in two modes. First one, if the street lights in automatic mode, if any human or vehicle movement detected, the motion sensor triggers the microcontroller to turn the LEDs to their full brightness and it gets restored back to the dimming brightness. Another one is control mode, in the control mode it counts the road users both human beings and vehicles, and transfers the counted value to control room. Turn on / off can be controlled manually from EB station through the same wireless medium. As per the user need only the street lights are operated in automatic mode or either the control mode.

VI RESULTS AND ANALYSIS

The management center is that the hub of the system, since it permits the visualization and control of the complete lighting system. The transmission system consists of Mi-Wi devices that receives data of the state of the lamps and sends it to a terminal. The processing unit consists of a terminal with a serial UART interface that receives data regarding the state of the lamps provided by a Mi-Wi device, connected to the UART interface. The terminal is needed for graphical presentation of results. Additionally, knowledge on lamps operation are received along with the

lamp address, consequently all faults can be easily identified. The graphical interface permits to visualize the state of the system (Fig. 6) with the state of the light and the power consumption of every lamp.

state of the lamps and sends it to a terminal. The processing unit consists of a terminal with a serial UART interface that receives data regarding the state of the lamps provided by a Mi-Wi device, connected to the UART interface. The terminal is needed for graphical presentation of results. Additionally, knowledge on lamps operation are received along with the lamp address, consequently all faults can be easily identified. The graphical interface permits to visualize the state of the system (Fig. 6) with the state of the light and the power consumption of every lamp.



Figure-6: Exemplary GUI of the lighting system.

The results of different failure conditions i.e. of wire fault and lamp malfunction are presented in Figure 7 and Figure 8.

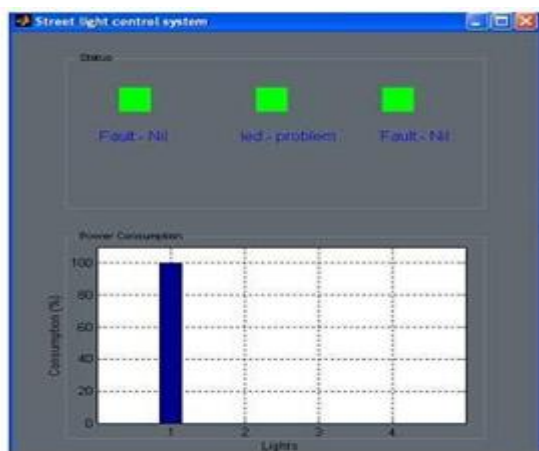

Figure 7: Fault condition due to lamp failure

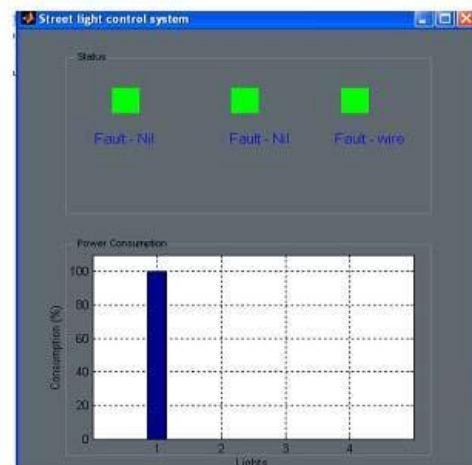

Figure 8: Wire fault condition

VII ESTIMATION OF PRICES AND SAVINGS

This proposed system may be criticized as being expensive however we must consider its advantages slightly higher prices of the lamp posts are compensated by lack of costly wiring and the availability of power network and considerably lower prices of maintenance (due to central management and reliability of LEDs). Energy savings are of utmost importance today. The goal is, therefore, the reduction of operating prices of street lighting with the creation of a system characterized by straightforward installation and low power consumption, powered by a renewable supply of energy through solar panels with no harmful atmosphere emissions and minimizing light pollution. Making a short comparison with the normal street lighting systems: Supposing the HID lamp is switched on for 4,000 hours per year. One streetlight has a median consumption of 200 W yearly. With the system presented in this paper, every lamp uses about 20-25 W (95% of energy consumed by the LEDs). Based on the field tests another possibility of energy savings becomes evident. Classical system consumes energy independently if it is needed or not. It is active for about 10 hours daily and the total number of working hours is about 300 per month, versus 87-108 hours proposed system, savings of about 66% to 71% are expected. The savings may be improved by using more efficient LEDs, since the consumed energy almost entirely depends on LEDs consumption.

VIII CONCLUSION

Street-lights are a large consumer of energy for cities, using up to 50 percent of a city's energy budget. If every city installs the proposed system then a lot of power can be saved. Proposed system is power saving mechanism for street lights by using LED lamps as replacement of normal lamps and using special power savings mechanism for microcontroller and Mi-Wi modules. It turns out most reliable and time efficient way to switch ON/OFF street-lights. It provides an effective measure to save energy by preventing unnecessary wastage of electricity, caused due to manual switching or lighting of street-lights when it is not required. It adopts a dynamic control methodology for traffic flow. The proposed system is especially appropriate for street lighting in remote urban and rural areas where the traffic is low at times. The system is versatile, extendable and totally adjustable to user needs.

REFERENCES

- [1] B. Ackermann, V. Schulz, C. Martiny, A. Hilgers, X. Zhu, "Control of LEDs", 1-4244-0365-0/06/\$20.00 (c) 2006 IEEE.
- [2] Yuichi Aoyama, Toshiaki Yachi, "An LED Module Array System Designed for Streetlight Use", IEEE Energy2030 Atlanta, GA USA, 17-18 November, 2008.
- [3] WU Yue 1, 2, SHI Changhong³, ZHANG Xianghong³, YANG Wei¹, "Design of New Intelligent Street Light Control System", 2010 8th IEEE International Conference on Control and Automation Xiamen, China, June 9-11, 2010.

- [4] Hengyu Wu, Minli Tang * (Corresponding author), Guo Huang,” Design of Multi-functional Street Light Control System Based on AT89S52 Single-chip Microcomputer”, 2010 2nd International Conference on Industrial Mechatronics and Automation.
- [5] SHENTU Xudan^{1,2}; LI Wenjun¹; SUN Lingling¹;GONG Siliang^{2,3},” A New Streetlight Monitoring System Based On Wireless Sensor Networks”, 978-1-4244- 7618-3 /10/\$26.00 ©2010 IEEE