

# **Compact Regenerative Breaking Scheme for a PM BLDC Motor Driven Electric Two-Wheeler**

**Mr. Gopal Rathod<sup>1</sup>, Prof.P.C.Tapre<sup>2</sup>**

*<sup>1,2</sup>Department of Electrical Engineering , SND COE & R C, Nashik Maharashtra(India)*

## **ABSTRACT**

*This Paper presents compact regenerative breaking scheme for a PM BLDC motor driven electric two wheeler. Electric vehicles have been attracting unprecedented attention in light of the volatile market prices and prospect of diminishing supplies of fuel. Advances in battery technology and significant improvements in electrical motor efficiency have made electric vehicles an attractive alternative, especially for short distance commuting. This paper describes the application of Brushless DC (BLDC) motor technology in an electric vehicle with special operation on regenerative breaking. BLDC motors are frequently used for electric vehicle due to its high efficiency & robustness. In an electric vehicle, regenerative breaking helps to conserve energy by charging the battery, thus extending the driving range of the vehicle.*

**Keywords: Regenerative breaking, BLDC Motor, EVs, SOC, MOSFET, IGBT**

## **I. INTRODUCTION**

A pure electric vehicle (PEV) contains three major parts: the power battery (usually in series as an energy-storage unit), the driving motor [can be induction motor (IM), brushless direct-current motor (BLDCM) and switched reluctance machine (SRM), and the power converter controller. Among all the driving motors, the brushless direct-current (DC) motor has many advantages over other brush DC motors, IMs and switch reluctance machines. It has the merits of simple structure, high efficiency, electronic commutating device, high starting torque, noiseless operation and high speed range, etc. Hence, the brushless DC motor has been widely used in EVs. Conventional EVs use mechanical brakes to increase the friction of the wheel for deceleration purposes. Thus, the breaking kinetic energy is wasted. With this problem in mind, this paper will discuss how to convert the kinetic energy into electrical energy that can be recharged to the battery. As a result, regenerative breaking can realize both electric breaking and energy savings [1].

Regenerative breaking can be used in an EV as a way of recouping energy during breaking, which is not possible to do in conventional ICE vehicles [1,2,3,4,5]. Regenerative breaking is the process of feeding energy from the drive motor back into the battery during the breaking process, when the vehicle's inertia forces the motor into generator mode. In this mode, the battery is seen as a load by the machine, thus providing a breaking force on the vehicle.

## II. PM BLDC MOTOR

Principally, a brushless DC (BLDC) motor is an inside-out permanent magnet DC motor, in which the conventional multi-segment commutator, which acts as a mechanical rectifier, is replaced with an electronic circuit to do the commutation. Consequently, a BLDC motor requires less maintenance and is quite robust. A BLDC motor has a higher efficiency than a conventional DC motor with brushes [6]. However, a BLDC motor requires relatively complex electronics for control.

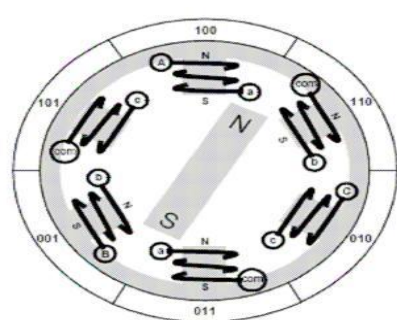

Fig 1. Permanent Magnet BLDC motor

In a BLDC motor permanent magnets are mounted on the rotor with the armature windings being housed on the stator with a laminated steel core, as illustrated in Figure 1. Rotation is initiated and maintained by sequentially energising opposite pairs of pole windings, which are said to form phases. Knowledge of rotor position is critical to correctly energising the windings to sustain motion. The rotor position information is obtained either from Hall Effect sensors or from coil EMF measurements

## III. PM BLDC MOTOR OPERATION

Two separate modules (stages) are required in order to control a BLDC motor: a power module and a control module.

A BLDC motor requires a DC source voltage to be applied to the stator windings in a sequence so as to sustain rotation. This is done by electronic switching using an inverter as shown in Figure 2. The inverter circuit employs a half H-Bridge for each stator winding.

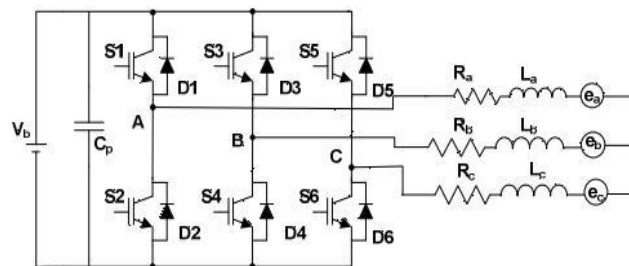
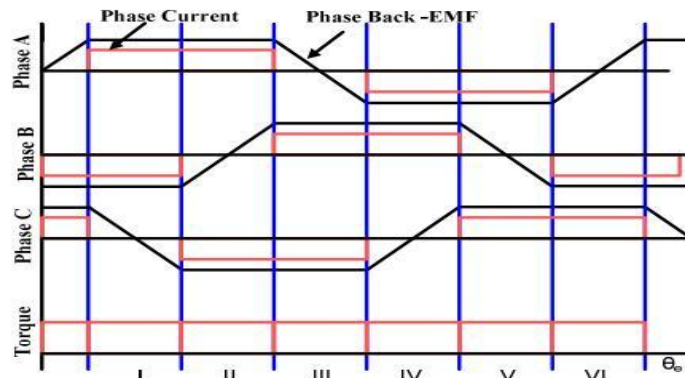

Fig. 2 Equivalent circuit of an inverter driven 3-phase PM BLDC motor

In Fig.2  $R_a, R_b, R_c$  are the phase resistances,  $L_a, L_b, L_c$  are the phase inductances &  $e_a, e_b, e_c$  are the phase back-EMFs in the phases A,B,C respectively.  $S_1$  to  $S_6$  are the switching devices &  $D_1$  to  $D_6$  are freewheeling diodes.  $C_p$  is the dc-link capacitor used for maintaining the dc link voltage. In the case of BLDC motor, it is operated in 6 states. Hence the complete commutation cycle of 360 will have six equal intervals.



**Fig. 3. Ideal back-EMF, phase current and developed torque profiles in a 3-phase PM BLDC motor**

Generally, the switches  $S_1$  to  $S_6$  are operated in a particular sequence based on the position feedbacks received from the rotor position sensors such as hall-effect sensors. And to control the torque developed by motor, pulse width modulation scheme is used. In the case of a BLDC motor with three pairs of stator windings, a pair of switches must be turned on sequentially in the correct order to energise a pair of windings.

A number of switching devices can be used in the inverter circuit; however MOSFET and IGBT devices are the most common in high power applications due to their low output impedance. A microcontroller is commonly used to read rotor position information from the Hall Effect sensors and determine which phase to energise. Alternatively, phase EMFs can be monitored to determine the rotor position in sensor less applications.

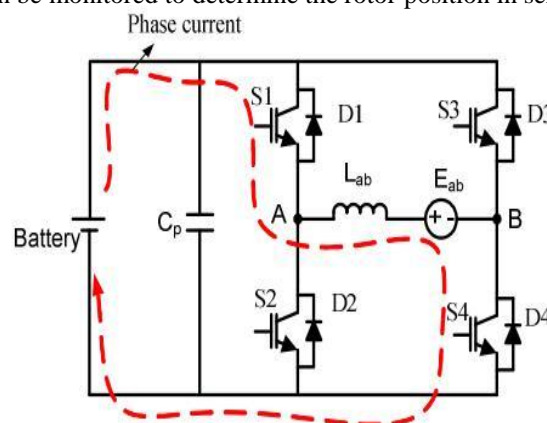

**(a) When  $S_1$  and  $S_4$  are closed with PWM-ON (State-I) for motoring mode**

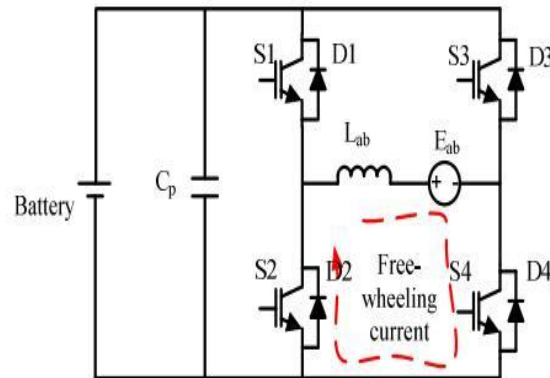

(b) When S4 only is closed (State-I) for free-wheeling mode

Fig. 4. Equivalent circuit of the 3-phase PM BLDC motor during the motoring mode and free-wheeling modes. During the normal mode, the switches S1, and S4 are operated in pulse width modulation ON condition, feeding power to the phases A & B of the motor. (PWM) switching mode; the high side switches S1, S3, and S5 are operated in normal high or low. To the contrary, lower leg switches are operated in PWM switching mode during the energy-regenerative mode.

### 3.1 Normal Mode:-

During state I, the conduction mode represents that the switches S1 and S4 are turned on simultaneously. The inductor current  $i_{ab}$  would be increased by the energized current loop ion of the winding. At this time, since the magnetic field of the winding is increased due to  $i_{ab}$  increase, a reverse induction voltage  $E_{ab}$  has to resist the variation of the magnetic field according to Lenz's Law. That is the so-called the armature back EMF of the motor.

During another mode (freewheeling mode), the switch S1 is turned off, and S4 is still on such that the inductor current will flow into the freewheeling diode D6 and the switch S2, which makes a discharging current path  $I_{off}$ . Accordingly, the corresponding sequences of S1, S4, input current  $I_{in}$  and phase current  $i_{ab}$  are shown in Fig.4

### 3.2 Energy Regeneration Mode:-

In this paper we uses the line back EMFs which is induced in phase windings of motor & Hall signals, to generate switching pulses to the inverter. Ultra capacitor as an energy storage with very high power delivery and capability to encounter the fast dynamic changes without any damages is the best substitute for battery in acceleration times.

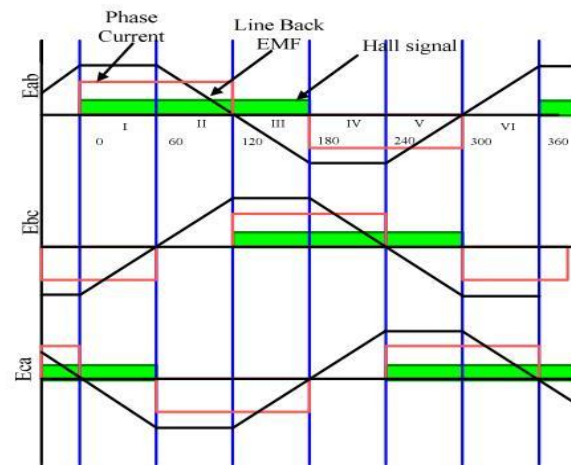

**Fig.5. Regenerative braking strategy in a 3-phase PM BLDC motor using the line back-EMF**

When the motor is forward braking in half bridge modulation mode, only three power devices (S2,S4,S6) at the low bridge arm are switched on and off at a controlled duty cycle for 120 electrical degrees respectively while the other three power devices ( S1 , S3 , S5 ) at the high bridge arm are always switched off, and the conductive time of S2 ,S4 ,S6 is that of S5 ,S1 ,S3 (forward driving) respectively[7].

Fig.6 gives the operating condition in regenerative mode of operation of the motor.Fig.6 (a) shows the switches S2 & S3 in PWM On condition, feeding power to the phases A & B of the motor from the battery. This feeding power is in opposite direction, hence fast braking is achieved. And Fig.6 (b) shows switches S2 & S3 are in OFF condition. So that motor feeds power back to the battery through Diode

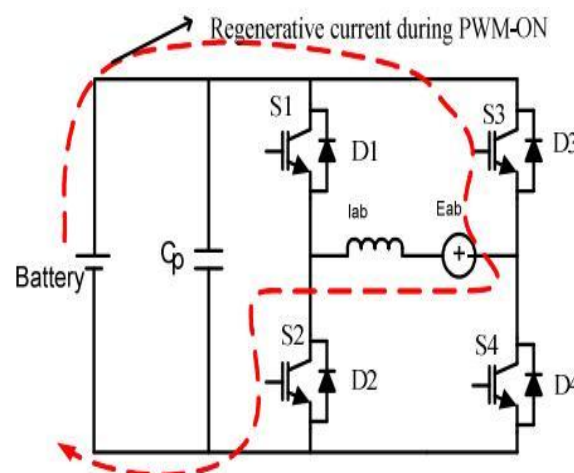

**(a) When S2 and S3 are closed with PWM-ON (State-I) for regenerative mode**

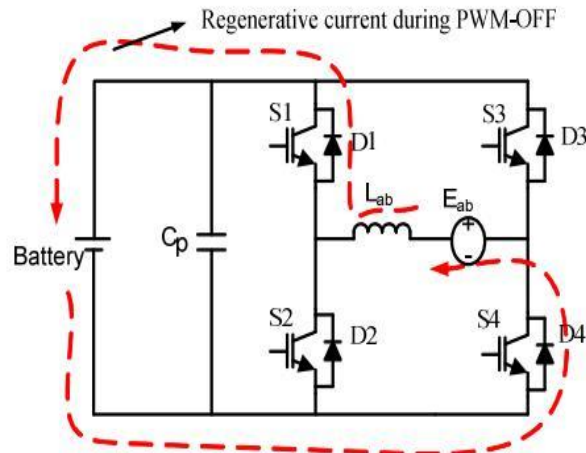

(b) When S2 and S3 are open with PWM-OFF (state- I) for regenerative mode

Fig.6. Equivalent circuit of the 3-phase PM BLDC motor during the regenerative mode

#### IV. SIMULATION OF REGENERATIVE BREAKING BASED ON LINE BACK-EMF METHOD

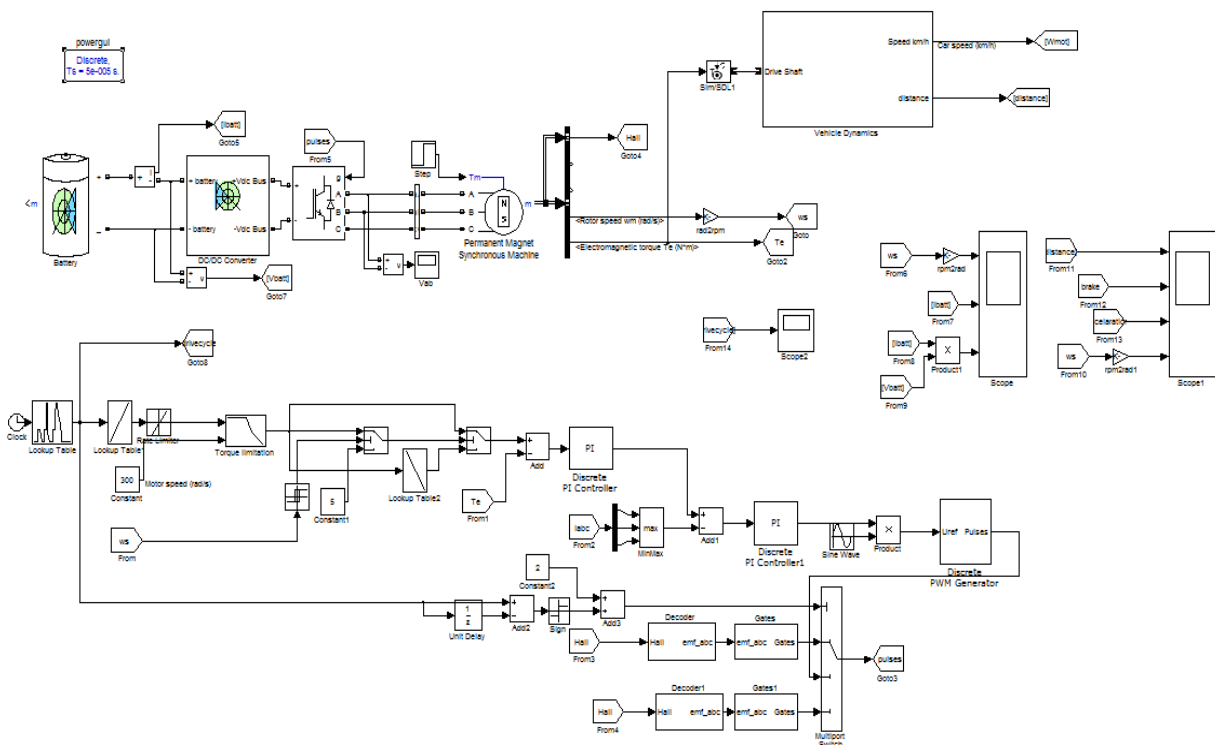
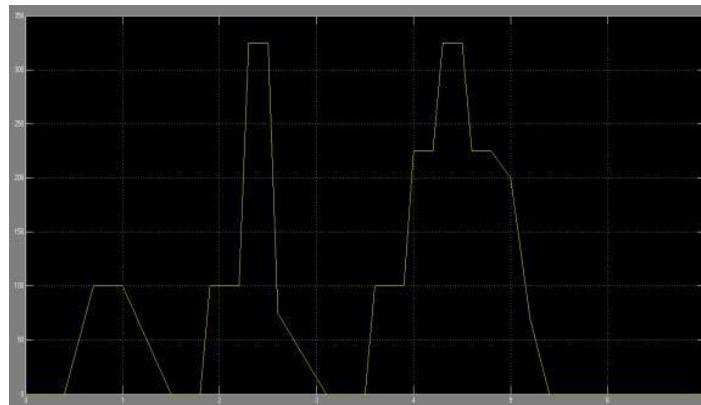

Fig.7. Simulink model of the 3-phase PM BLDC motor during the regenerative mode

In this Paper, both concept of mechanical breaking & regenerative breaking is studied. Generally drive cycle has three modes of operation

1. Acceleration mode
2. De-acceleration mode
3. Constant speed mode

The maximum vehicle speed considered is 25 kmph corresponding to the motor speed of 330 rpm.



**Fig.8. Drive cycle with the maximum vehicle speed of 25kmph( corresponding motor speed of 330rpm)**

The simulation results are given in Figures 9 and 10. From the Fig. 9, it can be observed that the vehicle is exactly following the drive-cycle given by the user. The regenerative breaking regions are indicated in circles. If the speed of the vehicle is such that the motor speed is below 100 rpm, the regenerative breaking is not that effective and only the mechanical breaking is employed. In other regions, where speed of the vehicle is such that the motor speed is more than 100 rpm and less than 330 rpm, then the regenerative breaking is effective and feeds the regenerative power to the battery.

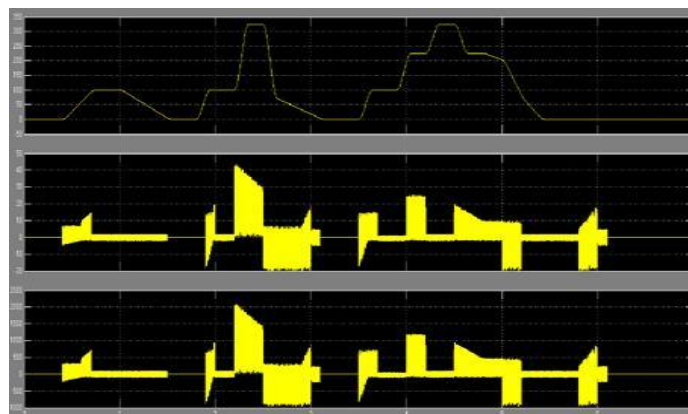

**Fig.9. Battery power and current during combination of regenerative braking and mechanical braking.**

Fig.10. indicates the Acceleration signal, brake signal, speed of the vehicle and the distance travelled in the given drive cycle. Driver model used in this work is exactly following the user input and during acceleration regions, the brake signal is zero. Similarly, during the braking regions, the acceleration signal is zero. At constant speeds vehicle is taking minimum current.

Fig.11. represents the state of charge (SOC) during the mechanical braking as well as the regenerative braking so that a clear distinction can be understood that, the proposed regenerative method of braking leaves a far better SOC than the mechanical braking.

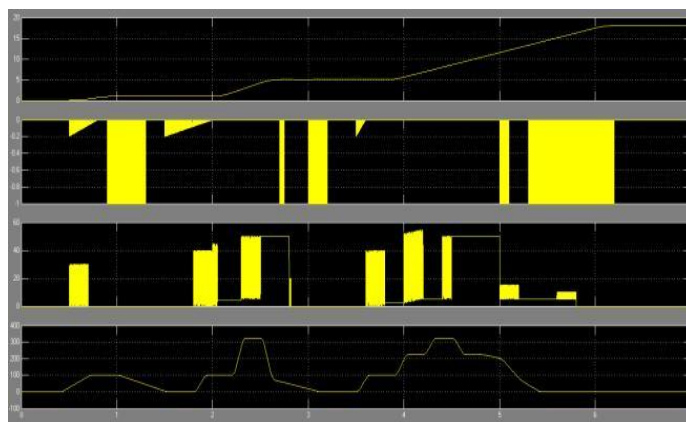

**Fig.10. Acceleration signal, brake signal vehicle speed and distance travelled.**

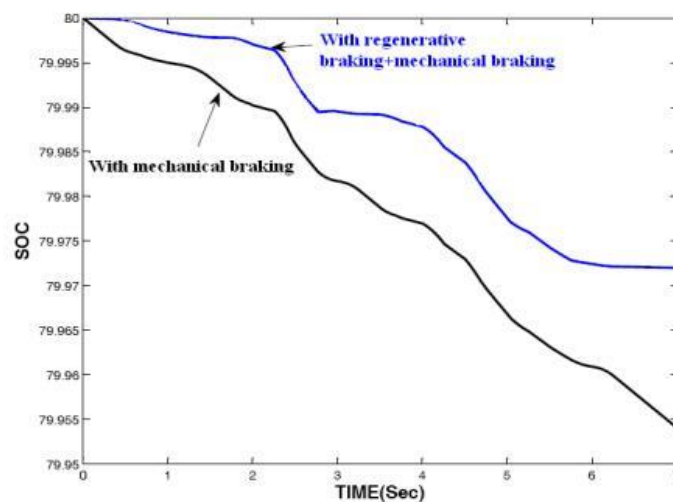

**Fig.11. Comparison of SOC for different braking methods**



#### **IV. CONCLUSIONS**

In this paper, the line back –EMF based regeneration Technique is used. The performance presented in this paper gives better than conventional mechanical braking in two wheeler EVs. Ultra capacitor is used as secondary energy storage, with regards to its remarkable properties, has used to improve the acceleration performance and regenerative braking efficiency. Further, the presented method is the simplest one among the known regenerative methods in terms of the simplicity of the system, ease of implementation. This control system developed higher breaking torque than conventional mechanical braking. The proposed control strategy also gives a higher electric regenerative braking efficiency and better control performance. In an electric vehicle, regenerative braking helps to conserve energy by charging the battery, thus extending the driving range of the vehicle.

#### **APPENDIX**

##### *Vehicle parameters*

Rolling friction =  $C_{roll} = 0.018$

Aero dynamic drag co-efficient =  $C_d = 0.92$

$A_f$  = frontal area of the vehicle = 0.6 m<sup>2</sup>

$V_w$  = wind velocity = 0 m/s

Gross vehicle weight = 175 kg Gradient = 0°

Maximum vehicle Speed = 25 kmph.

##### *Battery Parameters*

Battery voltage = 48V

Battery internal resistance = 0.056 ohms

Initial state of charge (SOC) = 80%

##### *PM BLDC hub motor Parameters*

Number of poles = 46

Stator phase resistance = 0.18 ohms

Maximum peak current = 50 A

Study state current = 20 A

Power rating = 350 W

##### *Driver model*

Driver model is a simple PI – controller

$K_P = 5$   $K_i = 1.1$

*Current controller*

Current controller is a simple PI – controller

$K_P = 0.1$   $K_i = 0.1$

**REFERENCES**

- [1] Cody J, 2008, “*Regenerative Breaking Control for a BLDC Motor in Electric Vehicle Applications*”, Honours Paper in Bachelor of Engineering degree, University of South Australia, School of Electrical and Information Engineering.
- [2] Ehsani, M.; Falahi, M.; Lotfifard, S. Vehicle to grid services: Potential and applications. *Energies* 2012, 5, 4076–4090.
- [3] Falahi, M.; Chou, H.M.; Ehsani, M.; Xie, L.; Butler-Purpy, K.L. “*Potential power quality benefits of electric vehicles*”. *IEEE Trans. Sustain. Energy* 2013, 4, 1016–1023.
- [4] J. Shen, X.J.; Chen, S.; Li, G.; Zhang, Y.; Jiang, X.; Lie, T.T. “*Configure methodology of onboard super capacitor array for recycling regenerative breaking energy of URT vehicles*”. *IEEE Trans. Ind. Appl.* 2013, 49, 1678–1686.
- [5] Yang, M.-J.; Jhou, H.-L.; Ma, B.-Y.; Shyu, K.-K. “*A cost-effective method of electric brake with energy regeneration for electric vehicles*”. *IEEE Trans. Ind. Electron.* 2009, 56, 2203– 2212.
- [6] Emadi, A., 2005, “*Handbook of Automotive Power Electronics and Motor Drives*”, CRC Taylor & Francis.
- [7] zhang chuanwai “*simulation study of h control for generative breaking of electric vehicle.*”