

Comparative Study on Post - Tensioned and Reinforced Concrete flat Slab Systems for a Multistory Building

Thayapraba M

Civil Department, NIT Trichy, (India)

ABSTRACT

Designers have a huge number of choices in building design, especially in the selection of a flooring framing systems. Several advantages are involved in using post-tensioning which have resulted in it becoming more and more systematically used in construction practices. Post-tensioned flat slabs are a good example as they allow a significant reduction of the slab's thickness by maximizing the spans, and serving to increase the number of floors, which can be of particular interest for high-rise buildings. An attempt was made in the present study to compare the effectiveness of Post-Tensioned flat slab system over reinforced concrete flat slab system. Both the systems were modeled and analysed using SAP. Subsequently Microsoft design sheet was developed based on the design methodology. The results signify that Post Tensioned flat slabs are cheaper than the RCC slab systems for all the spans considered in the present study.

Keywords – Post Tensioning (PT), Post Tensioned Flat Slab, RCC Flat Slab, SAP model

I. INTRODUCTION

In India, currently there is a rapid need and increase in the number of high-rise buildings as a basic infrastructure for residential and commercial utility. Post-Tensioning is a method of reinforcing concrete or other materials with high-strength steel strands or bars, typically referred to as tendons. Post-tensioned structures can be designed to have minimal deflection and cracking, even under full load. Post-tensioning application includes office and apartment buildings, parking structures, slabs-on-ground, bridges, sports stadiums, rock and soil anchors, and water-tanks. Use of post-tensioning in slabs reduces the amount of concrete required for a structure which offsets increased cost of labor and equipment, decreases the amount of formwork required, decreases the overall height of floors which allows more floors for a particular building height, decreases the weight of the building which is a advantage in seismic design, and increases the allowable span length, creating more open space in a structure (Gupta 2006). Hence, in the present study addresses about the cost effectiveness of Post-Tensioned flat slab systems with reinforced concrete flat slab systems.

II. ADVANTAGES OF POST TENSIONING

Post-tensioning is the system of choice for parking structures since it allows a high degree of flexibility in the column layout, span lengths and ramp configurations. The Fig.1 and Fig.2 shows the conventional beam slab floor system as well as Post Tensioned flat slab floor system for 10 × 10 m span. In the conventional floor slab has a beam depth of 750 mm whereas Post Tensioning slab system consist of 180mm thick slab with the drop

of 400mm.



Fig.1 Conventional floor slab system with beam depth

Fig.2 PT floor slab system with slab thickness 180mm & drop 400mm



Fig.3 Flexibility in providing AC ducts

This shows the advantage of Post Tensioning by material saving with more clear space. In addition, it offers flexibility in providing air conditioning ducts which is shown in Fig.3. Observing the above mentioned benefits, the major advantages of Post Tensioning are listed below:

- 1) Post-tensioning allows greater span/depth ratio
- 2) For a given span post –tensioned floors requires less concrete.
- 3) If a significant part of the load is resisted by post –tensioning, the non-prestressed reinforcement can be simplified and standardized to a large degree. Furthermore material handling is reduced since the total tonnage of steel and concrete is less than for a R.C.floor.
- 4) Under permanent load, very good behavior in respect of deflections and cracking. Deflection due to loads is very less in Post-Tensioned sections when compared to reinforced concrete sections. The Fig.4 shows the deflection occurred in RCC and Post Tensioned beam due to external loading.

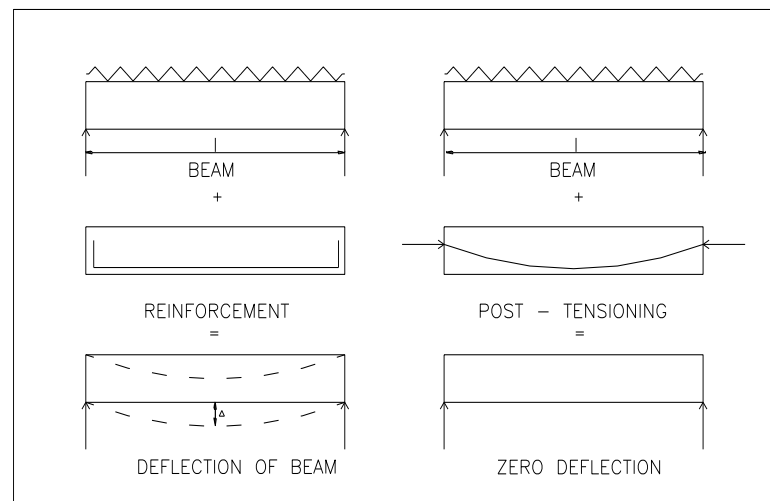

Fig.4 Comparison between RCC and Post-Tensioned Beam

- 5) Post-tensioning allows earlier stripping form work
- 6) Assembling of precast elements by post-tensioning avoids complicated reinforcing bar connections with in situ closure pours or welded steel connectors and thus can significantly reduce erection time
- 7) Usually the permanent floor load is largely balanced by draped post-tensioning tendons so that only the weight of the concrete of the floor above induces flexural stresses.

III. EFFECT OF FLOOR FRAMING IN TOTAL COST

While considering only the construction costs, it is evident that optimization of structural material consumption alone will result in quite modest overall savings since on one hand the structural cost makes only about 30 to 50% of the total construction cost and on the other hand more than half of the structural cost is labour cost, associated mainly to formwork. The floor framing system affects the cost in two ways:

- First it has a direct influence on the rest of the structure in that its weight determines the size of columns, walls and foundations, and its structural depth determines the total building height and thereby the quantity of cladding and vertical trunk lines. In seismic areas the floor weight also determines the member sizes of the lateral load resisting system.
- The second way the floor framing system affects the cost of the building relates to the total construction time. Both the time required to construct one floor and the time lag between the structural completion of the floor and the commencement of fit-out work such as electrical and mechanical services, suspended ceilings and decorating, are major factors influencing the time to completion of the building.

These considerations demonstrate that the optimization of the floor framing with regard to weight, structural depth and constructability goes a long way towards successful planning. The most cost significant structural element of a building is the floor framing. Fig.5 demonstrates the relative contribution of the floor framing to the total structural cost per unit floor area. While for low-rise buildings this contribution is almost 100%, the cost for columns and walls including their foundation and for the lateral load resisting system becomes more and more significant for taller buildings.

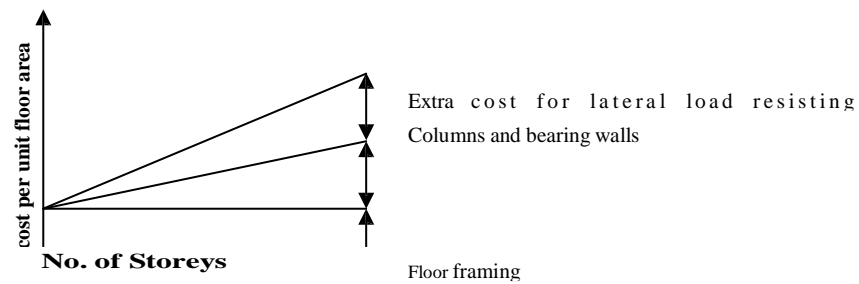

Fig.5 Contribution of Floor Framing to Total Structural Cost

The multitudes of different floor systems a designer can choose from are reviewed with respect to the selection criteria and the compatibility with post-tensioning. Typical view of the Post – Tensioned slab system during construction is shown in Fig.6.



Fig.6 Completed Tendon Layout for the Post- Tensioned Slab system

IV. SCOPE OF THE STUDY

Of all Structural costs, floor framing is usually the largest component. Likewise, the majority of a structure's formwork cost is usually associated with the horizontal elements. Accordingly, the first priority in designing for economy is selecting the structural system that offers lowest overall cost while meeting load requirements. Post-tensioning is the key to cost-effective multifamily construction. In addition, Post-tensioned structures can be designed to have minimal deflection and cracking, even under full load. Thinner floors provide lower building weight, which creates a corresponding reduction in other structural elements. There are also some associated labour and time savings.

The multitudes of different floor systems a designer can choose from are reviewed with respect to the selection criteria and the compatibility. Floor systems can be classified in different ways, for instance in-situ versus pre-cast floors, single span versus multi span floors, slab on beams versus flat slab, one-way versus two-way

systems, etc. The floor systems can be mainly classified into two categories, namely one-way systems and two-way systems. Each of these groups can then be further sub-divided by slab type and beam type. Floor systems considered in the present study is given in Fig.7 and Fig.8:

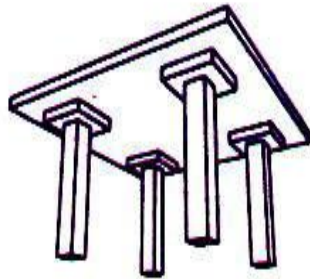

Fig. 7 Flat slab

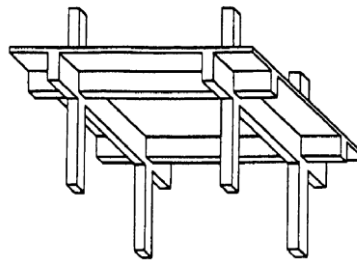

Fig. 8 Two way beam slab

Hence, the present study aims to compare the cost effectiveness of Post-Tensioned flat slab systems with reinforced concrete flat slab systems. For this purpose, a multistoried building (G + 8) with both the slab systems with different panels were considered. Both the systems are analysed using SAP and subsequently MS Excel program was developed based on the design methodology. Finally, cost comparison graphs are plotted for RCC and Post Tensioned slab systems with respect to span of the member.

V. METHODOLOGY

The above mentioned floor systems of RCC and Post Tensioning are analysed using SAP and the limit state design of the slab systems are done according to the specifications given in IS456:2000, BS8110:1997, ACI318:2003 and IS1343–1983 respectively. Building details, Post-Tensioning details considered in the present study is given below:

Building details

No of Storeys : G+8
Storey height : 3.5 m
No of Bays : 5
Panel sizes : (8x8)m,(9x9)m,(10x10)m, (11 x11)m, (12x12)m

Concrete grade for RCC and PT

Flat Slab : M35
Beam and Slab : M35
Concrete grade for PT : M35

Strength of steel in RCC : 415 N/mm^2

Post-Tensioning details

Nominal diameter : 12.9 mm

Nominal area : 98.7 mm²
Weight : 0.785 Kg/m
Strength of steel : 1860 N/mm²

The dimensions of the PT flat slab and RCC flat slab systems are given in Table.1.

Table.1 Dimensions of the Flat Slab

Panel size (m)	Column size (m)	Drop size (m)	Thickness (mm)			
			RCC		Post-Tensioning	
			Slab	Drop	Slab	Drop
8 x 8	0.8 x 0.8	3 x 3	225	400	180	350
9 x 9	0.9 x 0.9	3.5 x 3.5	250	500	200	350
10 x 10	1 x 1	4 x 4	275	500	200	400
11 x 11	1.1 x 1.1	4.25 x 4.25	300	600	225	450
12 x 12	1.2 x 1.2	4.5 x 4.5	350	650	250	550

VI. ANALYTICAL STUDY

Flat slabs in concrete are widely used because of their economy and fast construction, especially for buildings with long spans. The analysis and design of such slabs are complicated and time consuming. Therefore, in the present study SAP2000 software is used to analyse RCC and PT slabs. Subsequently, RCC flat slabs were designed and checked using manual calculations based on limit state design given by IS: 456 – 2000. For this purpose, a design program was prepared in MS Excel and reliability of the same was checked by manual design. Likewise, PT slabs were also designed based on the working stress method and it was checked with the limit state procedure given by IS 1343-1980.

The details of the reinforcements are obtained from these designs and they are converted in quantities and corresponding cost for each system is calculated. Finally, the cost comparison graphs are generated for RCC and Post Tensioned flat slab systems. Rates are taken from Delhi Schedule of Rates (DSR 2013) published by CPWD. The typical view of the (8x8) m flat slab system and the deflected shape of the same in SAP is shown in Fig.9 & Fig.10.

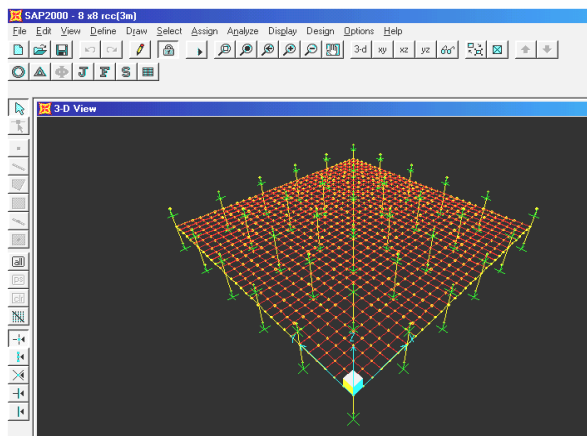

Fig.9 RCC Flat slab (8 x8) m Panel

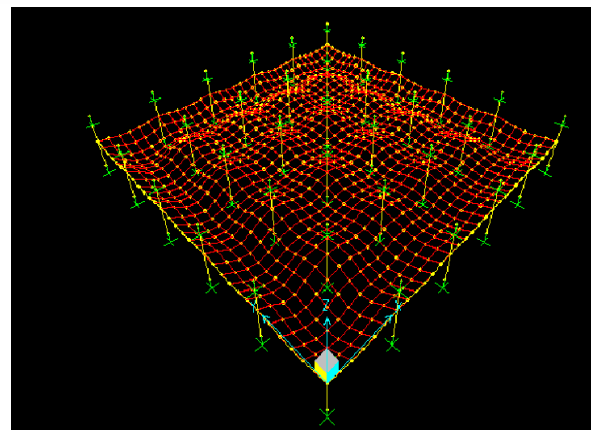

Fig.10 Deflected shape of the Flat slab

VII. RESULTS AND DISCUSSION

The design of RCC flat slab is done by limit state method according to the specifications given in IS 456:2000, BS 8110:1997 and ACI 318:2003. The design of Post-tensioning flat slab is done limit state method according to the specifications given in IS 1343:1980, BS 8110:1997 and ACI 318:2003. Then they are checked against Punching shear and deflection. The design details (Max + ve and Max - ve moments) are listed in the following Tables. 2 and 3. Typical moment diagram for panel size (8 x8) m is shown in Fig.11.

Table.2 Moments for RCC Flat Slab

Panel size (m)	Column strip moments(KNm/m)		Middle strip moments (KNm/m)	
	Max +ve	Max -ve	Max +ve	Max -ve
8 x 8	20.33	-174.04	16.1	-10.82
9 x 9	24.3	-214.9	20.93	-11.79
10 x 10	28.2	-315.2	23.56	-15.83
11 x 11	41.29	-430.05	31.5	-24.04
12 x 12	58.9	-548.63	44.56	-30.79

Table.3 Moments for Post-Tensioning Flat Slabs

Panel size (m)	Column strip moments(KNm/m)		Middle strip moments (KNm/m)	
	Max +ve	Max -ve	Max +ve	Max -ve
8 x 8	17.91	-139.04	14.23	-8.74
9 x 9	21.19	-182.47	18.5	-10.1
10 x 10	25.49	-243.93	21.32	-14.18
11 x 11	33.12	-327.31	27.51	-17.24
12 x 12	44.4	-423.08	37.4	-19.95

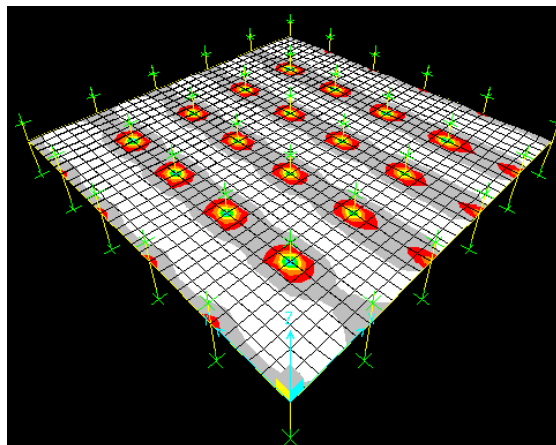

Fig.11 Typical moment diagram for panel size (8 x8) m

VIII. QUANTITY OF STEEL AND CONCRETE

The quantity of steel and concrete for RCC and Post Tensioned slab systems are calculated from the reinforcement details. The quantities and the cost of concrete, reinforcing steel, post tensioned steel and the shuttering excluding the labour charges for all the cases considered are given in Table.4. Trials had been made with different types of grades in concrete such as M25 and M35.

The various rates considered for the present study is as follows:

Rate of concrete = 4400/-per m^3

Rate of steel = 50/-per kg

Rate of form work = 400

Rate of post tensioned steel = 130/-per kg

Table. 4 Rate analysis for the panels considered

Description	Rates for different panel sizes (in .Rs)				

Cost comparison between RCC and PT flat slabs are presented in a graphical format in Fig. 12 and 13. The plot shows that, for the increase in the panel sizes the cost savings are also increasing with Post-tensioning.

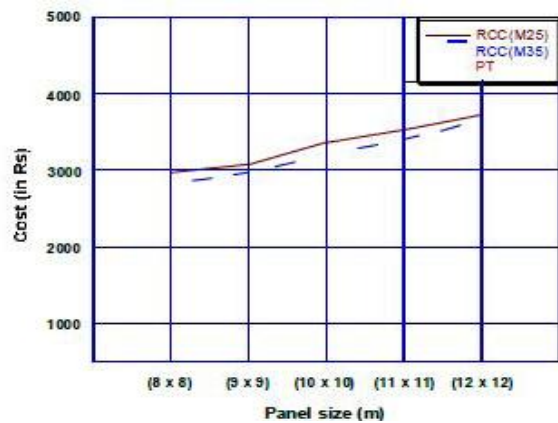

Fig.12 Cost comparison plot of RCC and PT flat slabs

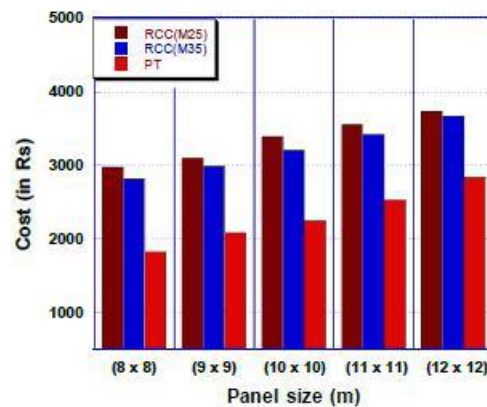

Fig.13 Cost comparison plot of RCC and PT flat slabs

IX. CONCLUSIONS

In the present study an attempt was made to compare the flat slab floor systems in both RCC with Post-Tensioning. The conclusion arrived from the work is stated below:

- For all the panel sizes considered, Post-Tensioning floor systems has proved to be cost effective compared to Reinforced concrete floor systems.
- For the increase in the panel sizes, the cost is also increasing steadily.
- The amount of concrete required for a floor is more for RCC flat slab whereas it is least for the post-tensioned flat slab floor system. This work can be extended to more number of panels which will be helpful to suggest a particular slab system which is most economical for suitable conditions.

REFERENCES

- [1.] Bijan, .O.A. and Jennifer, D.J. “Guidelines for Design of Post-Tensioned Floors”, Concrete International.2003.
- [2.] Gilbert, S. G. Murray, T. K. Scott, R. H. and Cleland, D. J. “Equivalent frame analysis methods for gravity loads in flat slab structures”.2000.
- [3.] Gupta, Pawan R , chief ed. Post-Tensioning Manual. 6th ed. Phoenix: PostTensioning Institute, 2006.
- [4.] “Indian Standard Code of Practice for Prestressed Concrete”. IS: 1343- 1980.
- [5.] Lin ,T.Y. and Burns, N. “Design of Prestressed Concrete Structures”, John Wiley & Sons, New York. 1981.
- [6.] Karve,S.R and Shah.V.L, “Limit State Theory and Design of Reinforced Concrete”.
- [7.] Krishna Raju, N.“Prestressed Concrete”, Fourth Edition, Tata McGraw- Hill Company Ltd., New Delhi. 2007.
- [8.] “Post-Tensioning Systems”, VSL Report, VSL International Ltd., Berne, Switzerland. 4.90/1.
- [9.] Purushothaman,P. 1984.“Reinforced concrete Structural elements”, Tata Mcgraw-hill, New Delhi.