

AUTOMATIC POWER SUPPLY CONTROLLER BY FOUR DIFFERENT SOURCES

Smt. Thilagavathy R¹, Smt. Spoorthi Y², Ms. Nalina H D³

^{1,2,3}Assistant Professor, Dept. of ECE, GSSSIETW, Mysuru, Karnataka, (India)

ABSTRACT

The main objective of this paper is to provide uninterrupted power supply to a load, by selecting the supply from any source out of four such as mains, inverter, solar and generator automatically in the absence of any of the source. The demand for electricity is increasing every day and frequent power cuts is causing many problems in various areas like industries, hospitals. An alternative arrangement for power source is a must. As it is not feasible to provide all four different sources of supply, one source with alternate switches are provided to get the same function.

Keywords: Generator, Inverter, Mains, Relay, Solar, Switches.

I. INTRODUCTION

An important requirement of electric power distribution systems is the need for automatic operation. In particular, the rapid and reliable transfer of the system from one power source to another during certain system events is important to achieving the reliability goals for such systems and the facility serves. However, the design of such an automatic transfer system is all-too-often considered "less important" than many other aspects of the overall power system design.

Nowadays, electrical power supply is one of the important elements in human being needs. The most of the human activities is dependent on electrical power supply. In other words, without electrical power supply, almost the whole of activities is become postponed or worse cancelled. For usage of daily routine, voltage supplied is within 240V ac. The need for power supply is paramount for the growth of a country, access to electricity as the basic form of energy supply to the masses is vital for the development of a nation's economy. The strategic role and policy of generation electricity in the development of an economy has always been appreciated by most developed nations, with the likes of France, Germany, and Italy. All these mentioned countries are well and truly developed countries that sustain the supply of energy to it environment for the purpose if industrial development.

The power sector provides a platform for economic development; electricity has brought about development in all area of productions and services. Electricity has become indispensable to socio-economic and industrial development of any nation. Using uninterrupted power supply in an automated mode, we always have a substitute arrangement as backup to take place of main power supply in case of power-cut in an emergency case, where the power cut cannot be avoided.

II. LITERATURE SURVEY

Robert Douwona [1] found out that emergency power systems were used as early as World War II on naval ships. In combat, a ship may lose the function of its steam engines which powers the steam-driven turbines for the generator. In such a case, one more diesel engines are used to drive backup generators. Early changeover switches relied on manual operation: two switches would be placed horizontally in line and the "ON" position facing each other, a rod placed in between, in order to operate the changeover switch, one source must be turned off, the rod moved to the other side and other turned on.

With adequate power supply base of the nation at the moment, it is almost impossible to supply electricity to consumers at all times. The unreliable public power supply has led many to the alternative power supply sources. In Nigeria today, the use of generators to power businesses and machines have become the norm. According to the Director-General of Centre for Management Development, Dr. Kabir Usman that Nigeria has the highest number of standby generators in Africa, averaging to every 2.5 people has at least one standby generator. He also pointed out that about 60million Nigerians spend 1.6trillion naira on generators annually. Many generators are in use; while some are manually started others are automatically activated.

According to Jonathan [2], manual changeover switch system still remains the oldest changeover switch box used by majority of the electricity consumers. Manual changeover switch box separates the source between a generator and public supply. Whenever there is power failure, change-over is done manually by an individual and the same happens when the public power is restored. This is usually accompanied by a loud noise and electrical sparks. According to him there are some of the limitations in the manual change over switch i.e. manual changeover is time wasting whenever there is power failure, it is strenuous to operate because a lot of energy is required, it causes device process or product damage, it has the potential to cause fire outbreak and it is usually accomplished by a lot of noise which may sometimes be psychologically destabilizing.

According to Mbaocha [3], Manual changeover maintenance is frequent because the changeover action causes tear and wear. According Katz R and Boriella [4], the main advantage of the sequential logic control power changeover switch is its simplicity. According to them there are some of the disadvantages in sequential logic control system i.e. the main possible clock rate is determined by the slowest logic path in the circuit, otherwise known as the critical path. Every logical calculation, from the simplest to the most complex must be complete in one clock cycle, so logic paths that complete their calculations quickly are idle much of time, waiting for the next clock pulse. The clock signal must be distributed to every flip-flop in the circuit. As the clock is usually a high frequency signal, this distribution consumes a relatively large amount of power and dissipates much heat. Even the flip-flop that is doing nothing consumes a small amount of power, thereby generating waste heat in the chip.

According to Shanmukha Nagaraj and Ramesh [5], in sequential logic control of power selection, sequential digital circuits are used to effect the detection and control of the supplied power. Sequential logic control involves only an automatic violation of the public power source in the event of power failure, but the generator activation to supply alternative power is done manually. In effect the sequential logic control is more efficient than the manual control.

According to Mbaocha [3], in microcontroller based controls, micro computers are employed with the resulting systems described as embedded. It gets information like data status from sensors and then issues control commands to actuators. One distinguishing feature of the embedded system from other real-time system is that they are only executing task relative to a fixed and well-defined work load. They do not provide any development environment; they are low-level programmed.

III. DESIGN METHODOLOGY

When the supply from all the sources (Mains, Solar, Inverter and generator) are ready, first "Normally open" switch is pressed then the mains get failed and the supply automatically shifts to inverter. To proceed further, second normally open switch is pressed then the inverter get failed and supply is provided from solar and so on. Priority is assigned to each power source in the order of Mains, Inverter, Solar and Generator. In case the mains power fails, the supply should automatically shift to Inverter but if Inverter also fails at the moment then the supply will automatically shift to next priority source.

Figure below explains the working and construction of the Auto power supply from four different sources. As shown in the diagram the four sources are Mains, Inverter, solar and Generator, four "Normally open" switches are used to show the failure of each supply, four relays are used to provide protection at each respective output. This output can be used to drive any load such as a lamp or motor. LEDs are used to display the source of supply.

Other case is when the power switches from one source to another source, say Inverter fails and supply shifts to solar, if the mains come back then the supply will automatically reach back to mains power instead of switching to solar. At the output of microcontroller, each output port is connected to positive dc voltage. Relays are used in contact with the output port to provide switching at the output.

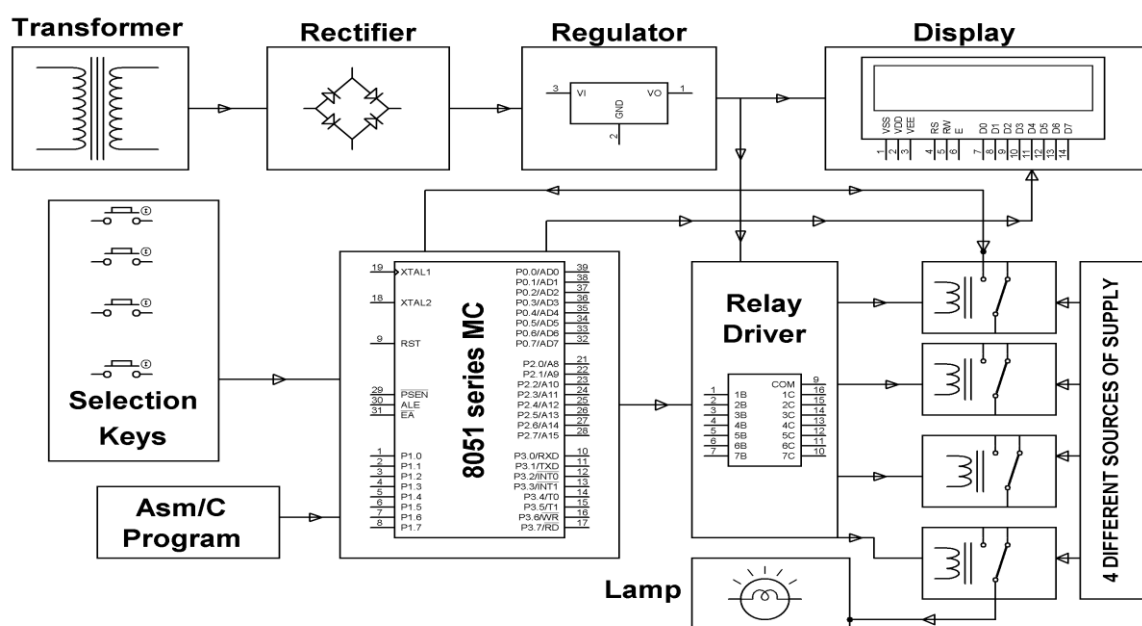

Fig 1.1: Block diagram

3.1 Working Principle

The paper uses an arrangement where four different sources of supply are channelized to a load so as to have an uninterrupted operation of the load. As it is not practicable to get four sources of supply such as mains supply, generator supply, inverter supply and solar supply, we use relays only. The source of 230v mains supply is used and assumed as if being fed from four different sources by connecting all the four incoming sources in parallel as seen in the schematic circuit diagram.

The ac source to the lamp is connected to relay 1 to relay 2 to relay 3 and relay 4 by making the entire 'NO' (normally open) contacts parallel and all the common contacts in parallel. Four push button switches representing failure of corresponding supply such as mains, inverter, solar and generator respectively connected to port 3.4, 3.5, 3.6 and 3.7. The port pin's are pulled up with 10k resistor's for reliable operation of achieving high and low logic by the program. It is so written that initially the relay driver IC ULN2003 pin number 1 gets a logic high from microcontroller port p0.1 that results in pin number 16 of the ULN 2003 going low to activate the relay 1 which results in the load i.e., lamps gets the supply through relay 1 'NO' contacts.

While the push button meant for mains is pressed that represents failure of mains supply resulting in port p0.2 (pin number 37) going high along with ULN2003 pin 2 and port p0.1 (pin number 38) goes low and pin 16 of ULN2003 going high. These results in pin number 15 of ULN2003 going low while pin number 16 goes high simultaneously.

This causes relay 2 to switch 'ON' that represents supply source from generator, thus the lamp gets supply now from the inverter in the event of mains fail. After that if both mains button and inverter buttons are pressed meaning both mains and inverter supply fail to the micro controller input that results in port 0.3 to go high at that time port 0.1 and 0.2 go to low.

Accordingly pin14 of ULN2003 goes low leaving pin16 and 15 to high such that the relay 3 is switched on while relay 1 and 2 remain in switched off condition. As the relay 3 corresponds to solar supply the lamp now gets the supply from solar. If the solar push button is pressed along with the mains and inverter button that simulates failure of mains, inverter and solar resulting in microcontroller port no 0.4 going high leaving port 0.1, 0.2, 0.3 low which enables the ULN2003 pin no 13 to go low leaving pin no 16, 15, and 14 high such that relay 4 is switched ON that gets supply from the generator source.

If the generator button is pressed together with mains, inverter, solar simulating failure of all the supply sources results in port 0.4, port 0.1,0.2,and 0.3 which results in pin no 13 of the ULN2003 going high together with 16,15,14. Thus all the relays are off leaving no supply to the lamp. One 16 x 2 lines LCD is used to display the condition of the supply sources and the load on real time basis.

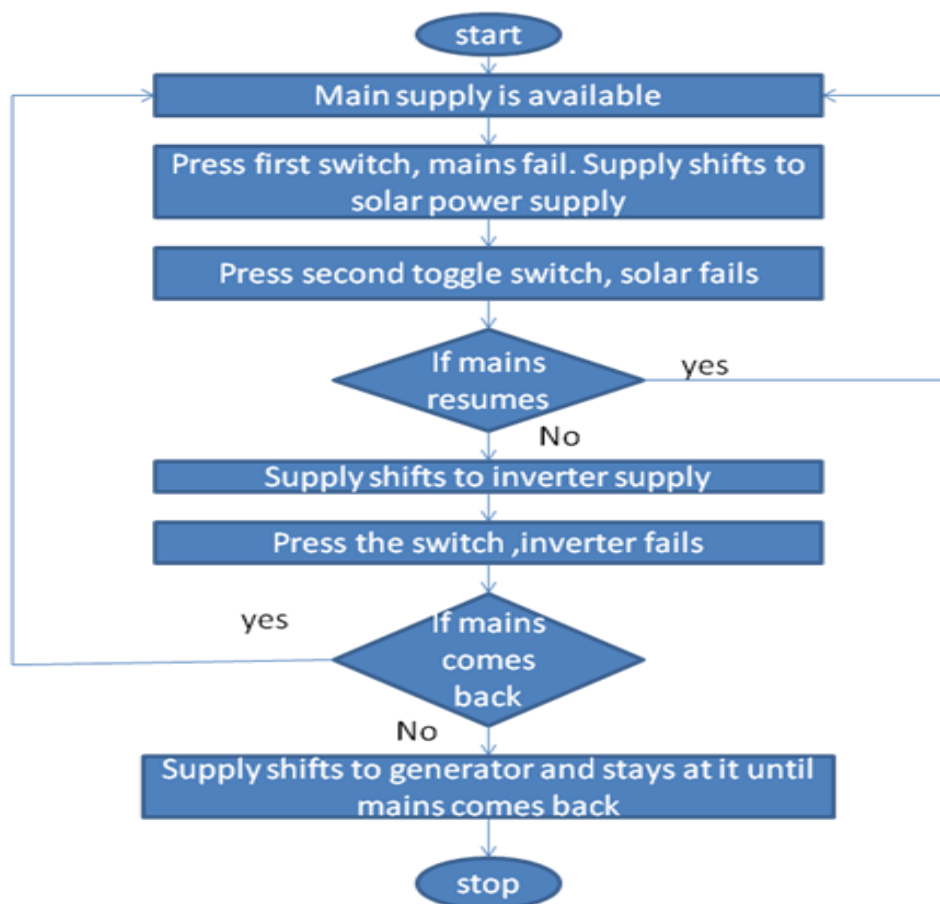

Fig 1.2: Flow Chart

IV. RESULTS

It provides a continuous power supply to the output load through any of the sources from which we are operating the device, i.e., inverter, solar and generator automatically in the absence of any of the source.

V. CONCLUSION & FUTURE SCOPE

The main scope of this paper is to provide a continuous power supply to the output load through any of the source in the absence of any of the source.

The paper can be further enhanced by using GSM, other sources like wind power and also then taking into consideration for using the best possible power whose cost remains lowest at that moment. The significance of this paper lies in its various advantages and wide places of applications where this project can be used efficiently.

VI. ACKNOWLEDGMENT

The authors express sincere acknowledgement to external guide A V Srikantan, principal, RTTC. Internal guide, Smt. Thilagavathy R, Assistant Professor, GSSSIETW for their helpful contribution in this project work. The

2nd International Conference on "Innovative Trends in Science, Engineering and Management"

YMCA, Connaught Place, New Delhi

05 November 2016, www.conferenceworld.in

ICITSEM-16

ISBN : 978-93-86171-10-8

authors also express sincere thanks to Dr. M V Sathyanarayana, HOD, Dept. of ECE, GSSSIETW and Dr. Sumitra Devi K A, Principal, GSSSIETW, Mysuru for their encouragement and support.

REFERENCES

- [1]. Robert Dowuona-Owoo (2008) - Design and construction of three phase automatic transfer switch. A thesis presented at regent university college of science and technology Ghana.
- [2]. L S Ezema, B U Peter, O O Haris, "DESIGN OF AUTOMATIC CHANGE OVER SWITCH WITH GENERATOR CONTROL MECHANISM", ISSN:2223-9944, vol 3, No 3, November 2003
- [3]. Jonathan (2007) – Manually Controlled Changeover System. Vol.2, No.5. November, 2011. PP 152 – 180
- [4]. Mbaocha C. (2012) - Smart Phase Changeover Switch using AT89C52 Microcontroller. Journal of Electrical and Electronics Engineering vol.1; Issue 3: PP 31-44
- [5]. Katz R and Boriella G (2005) - Contemporary Logic Design. 2nd edition. Prentice Hall, Italy. PP 445-589
- [6]. Shanmukha Nagaraj and Ramesh S (2013)-Programmable Logic Controlled Circuits. International Journal of Research in Engineering and Technology Vol.1, issue 2, July 2013; PP 111-116.
- [7]. L.S. Ezema, B.U. Peter, O.O. Harris (2012) - *Design of Automatic Change Over Switch With Generator Control Mechanism*. Electrical Power and Electronic Development Department, Projects Development Institute (PRODA), Enugu: Natural and Applied Science, Vol.3, No.3. November, 2012. PP 125 – 130.